

# Accessories



## Maintenance manual

Ver. 3.2

Publ.No. 571 908 253

# Contents

About this manual..... 1-IV  
 Maintenance manual version history .... 1-IV

## 1. General description

Batteries ..... 1-1  
 Power stick ..... 1-1  
 Power stick ..... 1-1  
 5600 internal battery ..... 1-2  
 Radio battery/External battery ..... 1-2  
 Battery adapters ..... 1-3  
 Multi adapter..... 1-3  
 Single adapter ..... 1-3  
 Power Stick charger adapter ..... 1-4  
 Chargers..... 1-5  
 Super charger..... 1-5  
 Single Charger ..... 1-6  
 Power supply 100 - 240V AC..... 1-7  
 Holders ..... 1-8  
 ACU holder..... 1-8  
 CU holder ..... 1-8  
 Holder for CU & radio/RS232..... 1-9  
 Holder for Battery..... 1-9  
 Holder for ACU ..... 1-9  
 RMT ..... 1-11  
 RMT 4000/4000LR ..... 1-11  
 RMT 600/600 LR ..... 1-12  
 RMT SLR ..... 1-13  
 Tracker target ATS ..... 1-15  
 RMT Super ..... 1-15  
 RMT 600 ATS ..... 1-16  
 RMT 600 SUPER Multi channel..... 1-17  
 RMT 600 TS..... 1-19  
 RMT 604 / 606 ..... 1-20  
 Rods ..... 1-21  
 Telescopic rod - 571 181 090 ..... 1-21  
 Telescopic rod - 571 126 088 ..... 1-22

Telescopic rod - 571 126 098 ..... 1-22  
 Targets ..... 1-23  
 Super prism standard ..... 1-23  
 Super prism sealed..... 1-23  
 Miniature prism ..... 1-23  
 Small tiltable reflector ..... 1-24  
 Large tiltable reflector ..... 1-24  
 Small tiltable reflector ..... 1-24  
 Large tiltable reflector ..... 1-25  
 Mini prism kit ..... 1-25  
 Tribrach ..... 1-26  
 Tribrach - 571 900 680 ..... 1-26  
 Tribrach - 571 905 560/2 ..... 1-26  
 Tribrach - 571 908 823 ..... 1-26  
 Tripod ..... 1-27  
 Tripod heavy duty - 571 126 275 ..... 1-27  
 GPS Antennas ..... 1-28  
 Compact antenna L1 ..... 1-28  
 Geodetic antenna L1 ..... 1-28  
 Compact antenna L1/L2 ..... 1-28  
 Geodetic antenna L1/L2 ..... 1-29  
 Choke ring antenna L1/L2 ..... 1-29  
 Mini geodetic antenna L1 ..... 1-30  
 Mini geodetic antenna L1/L2..... 1-30  
 GPS/GLONASS antenna L1..... 1-31

## 2. Technical description

Holders..... 2-1  
 ACU Holder..... 2-1  
 ..... 2-1  
 CU Holder..... 2-2  
 Holder for CU & radio/RS232..... 2-3  
 RMT..... 2-5  
 RMT 600/600 LR ..... 2-5  
 RMT SLR ..... 2-7  
 Tracker target ATS ..... 2-9

Tracker target Plus..... 2-9  
 Tracker target 600..... 2-9  
 Super RMT ..... 2-9  
 RMT 600 ATS (Hirose)..... 2-9  
 RMT 600 ATS (Canon)..... 2-9  
 RMT 600 ATS multi channel ..... 2-9  
 RMT 600 TS..... 2-13  
 RMT 604 / 606 ..... 2-17  
 Service ..... 2-17

### 3. Mechanical description

RMT ..... 3-1  
 RMT 604 - 571 204 310 ..... 3-1  
 RMT 606 - 571 204 610 ..... 3-1  
 Prism ring - 571 204 312 ..... 3-9  
 RMT SLR - 571 204 360 ..... 3-15  
 Tracker target ATS - 571 181 874..... 3-19  
 Tracker target Plus - 571 181 586 ..... 3-19  
 Tracker target 600 - 571 181 774 ..... 3-19  
 Super RMT - 571 181 870..... 3-19  
 RMT 600 ATS (Hirose) - 571 233 020 3-19  
 RMT 600 ATS (Canon) - 571 233 025 3-19  
 RMT 600 ATS multi channel - 571 233 035 3-19  
 Prism ring - 571 233 023 ..... 3-26  
 RMT 600 TS - 571 204 240..... 3-30  
 Holders ..... 3-35  
 ACU Holder - 571 224 091 ..... 3-35  
 CU Holder - 571 224 061 ..... 3-46  
 Tribrach ..... 3-58  
 Tribrach - 571 905 560/2 ..... 3-58  
 Tribrach - 571908 823 ..... 3-66  
 GPS Antennas..... 3-67  
 Compact antenna L1/L2 ..... 3-67  
 Geodetic antenna L1/L2 ..... 3-68

### 4. Component placement

Holders ..... 4-1

ACU Holder..... 4-1  
 CAP2 Board..... 4-1  
 BCB2 Board..... 4-2  
 CU Holder..... 4-3  
 CAP Board..... 4-3  
 TBD board ..... 4-4  
 RMT..... 4-5  
 RMT 606 Interconnection diagram ..... 4-5  
 Connectors, R15 ..... 4-6  
 MOD Board - RMT 606 ..... 4-7  
 RMT 604 Interconnection diagram ..... 4-8  
 MOD Board - RMT 604 ..... 4-9  
 BBR2 Board..... 4-10  
 ESF Board..... 4-10  
 FRT Board ..... 4-11  
 RFC Board..... 4-13  
 RFCM Board ..... 4-14  
 RMT 4000/4000 LR Interconnection diagram ..... 4-15  
 RMT 600 Interconnection diagram .... 4-15  
 RMT 600 LR Interconnection diagram 4-16  
 RMT/RMLR Board ..... 4-17  
 RMTSL Board ..... 4-19  
 RTG/RTLRL Board ..... 4-21  
 RTLRL Board ..... 4-23

### 5. Spare parts

Batteries ..... 5-1  
 Power stick - 571 126 277 ..... 5-1  
 Power stick - 571 126 287 ..... 5-1  
 5600 internal battery - 571 242 460..... 5-2  
 Radio battery/External battery - 571 204 270 5-2  
 Battery adapter..... 5-3  
 Multi adapter - 571 204 273 ..... 5-3  
 Single adapter - 571 204 256..... 5-5  
 Power stick charger adapter - 571 126 301 . 5-7  
 Chargers..... 5-8

Super charger - 571 906 145.....	5-8	Telescopic rod - 571 126 098 .....	5-48
Single charger - 571 906 214.....	5-8	Telescopic rod - 571 181 090 .....	5-49
Power supply - 571 906 146.....	5-9	RPU .....	5-51
Holders .....	5-10	RPU GDM 4000 & ATS.....	5-51
ACU Holder - 571 224 091 .....	5-10	Targets .....	5-57
CU holder - 571 224 061 .....	5-13	Super prism standard - 571 125 021 ...	5-57
Holder for CU & radio - 571 224 030	5-16	Super prism sealed 571126 070.....	5-57
Holder for CU & radio/RS232 - 571 204 242	5-16	Miniature prism - 571 126 060.....	5-58
Holder for battery - 571 204 300 .....	5-18	Small tiltable reflector - 571 126 100.	5-59
Holder for ACU - 571 212 080.....	5-19	Large tiltable reflector - 571 126 110.	5-61
The Walker - 571 126 297.....	5-20	Large tiltable reflector - 571 126 140.	5-63
RMT .....	5-21	Small tiltable reflector - 571 126 150.	5-65
RMT 4000 - 571 181 380 .....	5-21	Mini Prism Kit - 571 126 273.....	5-67
RMT 4000LR - 571 181 778 .....	5-21	Tribrach .....	5-68
RMT 600 - 571 202 220 .....	5-23	Tribrach - 571 900 680 .....	5-68
RMT 600LR - 571 202 480 .....	5-23	Tribrach - 571 905 560 .....	5-68
RMT SLR - 571 204 360.....	5-25	Tribrach - 571 900 680/2 .....	5-70
Tracker Target ATS - 571 181 874 ....	5-27	Tribrach - 571 905 560/2 .....	5-70
Tracker Target 600 - 571 181 774 .....	5-27	Tribrach - 571 908 823 .....	5-70
RMT Super - 571 181 870.....	5-29	Tripod .....	5-72
RMT600 ATS (Hirose) - 571 233 020	5-31	Tripod heavy duty.....	5-72
RMT 600 ATS (Canon) - 571 233 025	5-33	GPS Antenna .....	5-73
RMT Tracker Target Plus - 571 181 586	5-33	Compact antenna L1 - 571 212 240....	5-73
RMT 600 ATS multi channel - 571 233 035	5-35	Geodetic antenna L1 - 571 212 236....	5-75
Prism ring - 571 233 023 .....	5-37	Compact antenna L1/L2 - 571 212 430	5-77
RMT 600 TS - 571 204 240.....	5-39	Geodetic antenna L1/L2 - 571212 238	5-79
RMT 604 - 571 204 310 / RMT 606 - 571		Choke ring antenna L1/L2 - 571 212 426	5-80
204 610 .....	5-42	Mini geodetic antenna L1- 571 212 774.	5-80
Prism ring - 571 204 312 .....	5-44	Mini geodetic antenna L1/L2 - 571 212 777	5-80
Rods.....	5-46	GPS/GLONASS antenna L1 - 571 212 791	5-80
Telescopic rod - 571 126 088 .....	5-46		

## About this manual

This is the Maintenance manual for the Accessories. The idea of the manual is to use it during service/repairs. Information regarding modifications etc. can be found in:

- Service Bulletin (SB) - Replacing from January 2000 Technical Info.
- Technical Info (TI) - Information about program changes, new boards modifications etc.

## Maintenance manual version history

Version	Date	Changes
01.01	April 2000	First edition
01.02	August 2000	RMT SLR implemented
02.00	June 2001	Added units: <ul style="list-style-type: none"> <li>• RMT 600 SUPER</li> <li>• Multi Channel</li> <li>• RMT 600 ATS</li> <li>• Mini prism kit</li> <li>• Holders</li> </ul>
- 3	January 2002	Added units: <ul style="list-style-type: none"> <li>• CU Holder</li> <li>• RMT 606</li> <li>• RMT SLR (two Hirose connectors)</li> <li>• Power stick</li> <li>• 5600 internal battery</li> <li>• Radio/External battery</li> <li>• “The Walker”</li> <li>• Chargers</li> </ul>
- 3.1	January 2002	CU Holder spare part number changes
- 3.2	September 02	Trimble ACU Holder

# 1. General description

## Batteries

### Power stick

*fig 1-1*



Battery stick with Lemo connector. Charging of the battery is done via the lemo connector using the cable 571 208 064.

*Part.no:*

571 126 277

### Power stick

*fig 1-2*



Battery stick is without Lemo connector, can supply power from the top. In the top it is possible to mount a RMT606. It powers up the RMT606 for about 10 hours. No cables needs.

Charging of the battery is done via the Power stick charger adapter, [see page 1-4](#).

*Part.no:*

571 126 287

## 5600 internal battery

*fig 1-3*



NiMH 12V, 1.6 Ah battery. Charging via Super charger 571 906 145 or Single charger 571 906 214.

*Part.no:*

571 242 460

*fig 1-4*



## Radio battery/External battery

NiMH 12V, 3.5 Ah battery. Fits directly onto the external radio. In order to supply other units such as instruments, control units a single adapter 571 204 256 must be used. Charging via Super charger 571 906 145 or Single charger 571 906 214.

*Part.no:*

571 204 270

## Battery adapters

fig 1-5



### Multi adapter

With the Multi adapter up to 3 NiMH Batteries 571 204 270 can be inserted or the old NiCd radio battery, 571 202 310. 1, 2 or 3 Batteries can be used. If 2 or 3 batteries are connected at the same time the Multi adapter will always take the power from the battery with the highest voltage, switching between cells continuously and automatically. This means that all batteries will be empty at the same time.

The instrument will then indicate this with "Battery low".

The multi adapter has 4 Hirose connectors. They are configured as 2+2 when the serial connections are considered.

These extra connectors are particularly useful when external equipment is to be connected. Examples include Non SP radios, such as those used for GPS applications.

*Part.no:*

571 204 273

fig 1-6



### Single adapter

This new single adapter can be used together with one NiMH battery 571 204 270 or one old NiCd radio battery, 571 202 310. The Single adapter has two Hirose connectors. Transfer of data between e.g. two control units can therefore be made.

One NiMH battery (571 204 270) inserted in the Single adapter will provide an External battery with a capacity of 3.5 Ah.

This solution will replace the External battery 571 132 010.

*Part.no:*

571 204 256.



fig 1-7



## Power Stick charger adapter

The Power stick charger adapter is used to charge up the Power stick 571 126 287

*Part.no:*  
571 126 301

# Chargers

## Super charger

fig 1-8



Charging up to 4 batteries. Can be powered from cigarette lighter socket in your car or from Power supply 571 906 146, *see fig 1-10*.

The battery charger allows charging of NiCd batteries as well as NIMH batteries.

The charging process is fully-automatic and utilises a patent pending method. The charging current and charging voltage is continually adjusted on the behaviour of the connected battery. Different parameters influencing the charging process are i.e. the temperature, the age.

It is possible to select fast or slow charge mode. Fast mode is default, while slow mode can be selected with the push button on the front of the charger. The actual mode is indicated by the indicator. The mode can not be changed during the charging process.

The charger charges the batteries in sequence. When one battery is fully charged, charging will take place on the next battery and so on. When all batteries that are connected to the charger are fully charged trickle charging is activated. In the case a fully charged battery is connected to the charger equalizing of the cells in the battery automatically will take place. Indication on the green indicator, fully charged, is delayed and will not occur until the equalizing mode is finished. The time delay varies depending on the size (Ah) of the applied battery.

*Indicators:*

Yellow on	Slow mode charge.
Red on	No battery connected.
Red flashing	The battery is faulty or can not be charged.
Green on	The battery is being charged.
Green flashing	The battery is fully charged
All red and green flashing alternately	Too high supply voltage or/and too high internal charge temperature.
All indicators off	No or too low supply voltage

*Part.no:*  
571 906 145

## Single Charger

*fig 1-9*



The single battery charger is designed for both NiCd and NiMH batteries. It uses a peak voltage method to indicate when the battery is almost fully charged. To complete the charging it applies a constant top charging current of 100 mA until the maximum charging time timer has run out. Thereafter a pulsating trickle charging current will be applied to the battery as long as it is connected to the charger.

To prevent damage to the battery the charger has the following safety functions:

- A maximum charger time timer
- Maximum temperature stop if the battery becomes too hot.
- Battery over and under voltage detection

*Indicators:*

No bat.	No battery connected
Error	Charging error
Charg	Fast charging
100%	Battery charged

*Part.no:*  
571 906 214

## Power supply 100 - 240V AC

*fig 1-10*



Power supply for Super charger 571 906 145, the Geodimeter CU or two Trimble 5600 instruments. Connector for mains cable, cigarette lighter outlet and two Hirose connectors.

*Part.no:*

571 906 146

## Holders

### ACU holder

*fig 1-11*



Connect a ACU and a battery and the system is ready to use! No cables needed  
It can be used on all rods with dimensions from 20 mm up to 45 mm.  
The viewing angle on the holder can be adjusted so you can get an optimal  
visibility of the display.

*Part.no:*  
571 224 091

### CU holder

*fig 1-12*



Connect a battery and a radio and the system is ready to use! No cables needed  
It can be used on all rods with dimensions from 20 mm up to 45 mm.  
The viewing angle on the holder can be adjusted so you can get an optimal  
visibility of the display.

*Part.no:*  
571 224 061

fig 1-13

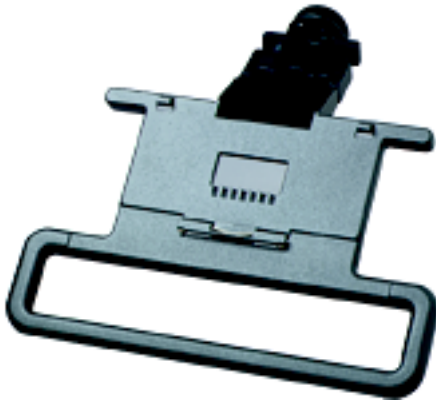

### Holder for CU & radio/RS232

Carries the keyboard unit and the external radio when mounted on the telescopic range pole.

Weight: 0,5 kg (1.1 lbs)

Part.no: 571 224 030

Holder same as above, but with an extra RS232 output.

Weight: 0,66 kg (1,45 lbs)

*Part.no:*

571 204 242

fig 1-14



### Holder for Battery

The battery holder is mainly designed to be placed on the rod for AutoLock application when there is no external radio to power a RMT that needs external power.

Use this battery holder together with the Single battery holder (571 204 256) and the External battery (571 204 270).

*Part.no:*

571 204 300

fig 1-15



### Holder for ACU

For mounting the control unit or the ACU on the telescopic rod, 571 181 090 or the range pole 571 126 088.

Weight 0.45 kg 1.0 lbs

*Part No:*

571 212 080

## Walker

*fig 1-16*

The Walker is a holder for the CU/radio/battery.

*Part No:*

571 126 297

## RMT

fig 1-17



### RMT 4000/4000LR

Geodimeter system 4000 and Geodimeter 4000 ATS active target for robotic applications.

The target can be powered from an external power source or from two type LR6/AA 1.5V alkaline batteries.

The RMT is made in two versions, standard and long range. The long range RMT will have a specified range of 700 m depending on weather conditions. The LR target is provided with an infrared diode with a more narrow beam than the standard RMT. Theoretically the LR unit should have about half the beam and double the range of the standard unit. This also means that the Long Range RMT has to be more accurately directed towards the instrument.

The pointing accuracy is better than 2mm at 200 meter (same as the Standard RMT). Generally the pointing accuracy, under normal turbulence and light conditions, can be written  $\pm(1 \text{ mm} + 0,3 \text{ mgon (1")})$ , expressed in standard deviation.

*RMT 4000 Part.no:*

571 181 380

*RMT 4000 LR Part.no:*

571 181 778



fig 1-18



## RMT 600/600 LR

Geodimeter system 600 & 600 ATS active target for Autolock and Robotic applications.

The target can be powered from an external power source or from two type LR6/AA 1.5V alkaline batteries.

The RMT is made in two versions, standard and long range. The long range RMT will have a specified range of 700 m in Robotic and up to 1000 m in Autolock, depending on weather conditions. The LR target is provided with an infrared diode with a more narrow beam than the standard RMT. This means that the Long Range RMT has to be more accurately directed towards the instrument. The pointing accuracy is better than 2mm at 200 meter (same as the Standard RMT). Generally the pointing accuracy, under normal turbulence and light conditions, can be written  $\pm(1 \text{ mm} + 0.3 \text{ mgon (1")}$ ), expressed in standard deviation.

We strongly recommend the use of 571 202 434 Tilttable Holder when using the RMT or RMT LR.

*RMT 600 Part.no:*

571 202 220

*RMT 600 LR Part.no:*

571 202 480

fig 1-19



## RMT SLR

The RMT SLR (Remote Measuring Target Super Long Range) is intended to be a target combining accurate short-range measurement with long-range capacity. This is achieved by using two different modes of operation. A short-range mode utilizes a single diode of the same type as used in present RMT 602 (571 202 220) and then the same range as this target. The long range mode utilizes 5 diodes, placed in a circle, of the type used in RMT Long Range (571 202 480) and it will then have a range with the tracker of theoretically 2,2 times the present long range target.

The short-range mode should be used on distances where it works and switch over to long-range mode be made when needed. The long-range mode also works well at short distance but the accuracy in short range with a single diode will be somewhat better than in long range.

### Connectors

The RMT SLR contains two Hirose connectors, one on the left side and one on the bottom.

### Operation:

PWR button: Sets the unit on/off. Indication with a twinkling green diode

LR button: Sets long-range mode. Indication with fix yellow diode

### Power:

Power Supply: SR Internal batteries (2x1,5 V), or external 12V (max 28V).

LR: External 12 V supply only (max 28 V)

If LR set with only internal battery a warning indication will be shown with fast twinkling yellow diode and the target will not work in long range.

*Power consumption:*

External supply 12 V, SR: about 50 mA

External supply 12 V, LR: about 120 mA

Internal supply, 3 V, SR: about 110 mA (this is about the same as for RMT 602, i.e. 8-12 hours operation with full output power, depending on battery type).

*Battery low:*

The RMT has a battery low indication. Intermittent twinkling of the green diode indicates internal batteries low voltage. Then full output power and range are not guaranteed, but the IR-diode is working until batteries are discharged down to about 2 V.

When using external battery the RMT will switch off the LR function at  $10,0 \pm 0,3$  V and the yellow LR diode starts twinkling. Power consumption goes down to 50 mW and the RMT can still be used in SR mode. After discharge down to about 5 V the RMT switches to internal batteries if available.

*Dimensions:*

Designed to fit into the "Tiltable holder for Remote Target", 571 202 434, with height to prism 135 mm (same as RMT 602).

Prism constant is 0 with standard Trimble prisms.

Centre line to backside 20 mm.

Circular level 8'2 mm on top.

*Range:*

Relative range: Range 3.5 times the range of RMT 602 or 2.2 times the range of RMT 602 Long Range. This means approx. 1500 meter Robotic and 2200 meters in Autolock. The Range will vary in different weather conditions.

*Accuracy:*

The accuracy of the target itself is  $< \pm 1$  mm in short range and  $< \pm 3$  mm in long range.

*Target recognition:*

Channels 0, 2, 4 and 6 are available for target recognition, where switch setting to 4 will be default and compatible with present targets, see mechanical description for correct setting of channels

*RMT SLR Part no:*

571 204 360

fig 1-20



## Tracker target ATS

Geodimeter 4000 ATS active target for robotic applications. It is a remote target with possibility to lock onto the target the full circle (360°). This is done via a reflector and 24 diodes.

The target can be mounted on vehicle, machinery or carried on a rod.

The target is powered from an external power source.

*Tracker target ATS Part.no:*

571 181 874

fig 1-21



## RMT Super

Geodimeter 600 active target for Autolock and robotic applications. It is a remote target with possibility to lock onto the target the full circle (360°). This is done via a reflector and 24 diodes.

The big advantage with RMT Super is that it is no longer necessary to keep the RMT directed towards the instrument when moving between points. The instrument receives the signal irrespective of the angle at which the RMT is directed and will stay "locked on".

The RMT Super will have a specified range of 700 m in Robotic and up to 1000 m in autolock, depending on weather conditions.

The pointing accuracy is better than 2mm at 200 meter (same as the Standard RMT). Generally the pointing accuracy, under normal turbulence and light conditions, can be written  $\pm(1 \text{ mm} + 0.3 \text{ mgon (1")})$ , expressed in standard deviation. The working range is  $\pm 25$  degrees.

Note! The RMT Super needs external power. You can either use an external battery or connect the RMT Super to the Ra-

dio. To use the connector on the radio you need to upgrade to the latest revision 626-04.01 on the radio and to the new version on the keyboard 632-03.00. The second connector is automatically switched of in present version.

*RMT Super Part.no:*

571 181 870

*fig 1-22*



## RMT 600 ATS

The Geodimeter 600 ATS exist in two different versions:

*RMT 600 ATS Hirose connector Part no:*

571 233 020

*RMT 600 ATS Cannon connector Part no:*

571 233 025

fig 1-23



## RMT 600 SUPER Multi channel

The RMT 600 SUPER Multi Channel replaces 571 233 020 RMT 600 ATS (Hirose) and 571 233 025 RMT 600 ATS (Cannon).

The Geodimeter 600 ATS is now shipped with target recognition as standard. The new feature consists of a new tracker function that can distinguish between four different target signals. This means that a surveying crew working near a machine controlled by an ATS do not have to worry about their target interfering with the instrument that is controlling the machine. There will be no risk that the ATS that controls the machine will lock on to the surveying crew's target instead of the target on the machine. Provided the targets are set to different channels and the surveying crew's target is not considerably closer to the instrument than the target on the machine. Nor will there be a risk of reduced accuracy because the ATS that controls the machine have both targets in its field of view. To use this function the machine must be equipped with a 571 233 035 RMT 600 SUPER Multi Channel target.

To select the target channel or target Id:

### *On the target:*

Turn the knob on the target to 0, 2, 4 or 6.

Channel 4 is the standard target channel, until now used by all Geodimeter 600 robotic and Autolock® total stations, so the machine should use one of the others.

### *On the 600 ATS and in Robotic:*

Press <RPU>, 4 RMT Config, 3 RMT Id. Then press <NO> until the display shows the same number as was set on the target. Then press <YES> to exit the RPU menu.

This can be done in both robotic and when the CU is mounted on the instrument.

### *C&C600 from PC:*

A command is sent to change the target Id setting in the tracker. PV,31=0/2/4/6.

There is no power switch on the target. The 0 setting of the knob is a valid target Id and not an off-position.

### *Power supply:*

The target is designed mainly for mounting on construction machinery. It is designed for a nominal input voltage of 12-28 V DC. It will withstand the somewhat higher voltage spikes common within a 24 V automotive system. It is designed to also withstand reversed voltage without damage to itself or

the system. The power connector is a Cannon (MIL-C bulkhead) to mate with the connector on the 571.181.593 Target Mount Plus and the 571 226 593/539 Target Mounts (White).

Power to the target is indicated by four red LED's flashing at 2 Hz.

*Input voltage:*

Max continuous:	28V
Min. voltage:	10.5V

*Power consumption:*

Input voltage 10.5V	approximately 300 mA or 3.15W
Input voltage 12.0V	approximately 275 mA or 3.3W
Input voltage 28.0V	approximately 125 mA or 3.5W

*Battery Low:*

There is no battery low indication or warning other than that the red diodes stop flashing when the voltage has dropped under the battery low level. If the voltage drops below the 10.5V battery low limit the target is switched off. The voltage must exceed 12.4 V again before the target is switched on again. This is to avoid that the infrared diodes flashes on an off at voltage near the battery low level due to a too long and thin power cable.

*Dimensions:*

(Same as 571 233 025 RMT 600 ATS).

Height:	173 mm/6 ¾"
Diameter:	105 mm/4 1/8"
Weight:	1060g/2.4lbs

*Range:*

Compared to 571 233 025 RMT 600 ATS the range is 15% less due to fewer diodes.

Robotic (search)	550 m/1800 ft.
Autolock® (track)	850 m/2700 ft.

The range will vary with weather and light conditions.

*Minimum operating distance:*

Dynamic operation with the RMT 600 SUPER Multi Channel: 10 m/30 ft.

*Prism constant:*

+0.002 m

*Accuracy:*

The accuracy of the target itself is  $\pm 1$  mm.

*RMT 600 SUPER Multi Channel target Part.no:*

571 233 035



fig 1-24



## RMT 600 TS

Target for Autolock and robotic applications. The target has a built in angle system for shorter search time.

The target can be powered from an external power source or internal with 2 1.5 V LR6/AA batteries.

The RMT 600 TS has the same main function as the RPU 4000. Before you start to search you must aim with the coarse sight (on the bottom of the RMT) towards the instrument, then press A/M. The rod doesn't need to be levelled, the important thing is that the coarse sight on the RMT is pointing towards the instrument. When you press A/M the RMT 600 TS sends a vertical angle to the instrument. The instrument recalculates the angle and tilts the telescope to the corresponding vertical angle. It starts to search  $\pm 30$  gon horizontally and if the target is not found, it will continue to search through the rest of the window horizontally. If the target is still not found the Instrument will continue to search in spiral within the search window. If you want to break the search you can always press CL (arrow left) key. The vertical sensor in the RMT needs to be calibrated before the search is started, this is indicated in the display. The only thing to do is to tilt the RMT up and down before the first search is started. Normally, this will be done automatically

by the movement created when the rod is carried to the first point.

Note! RMT 600 TS needs to be combined with a CU Holder RS-232 (571 204 242).

Without the Control Unit Holder with RS232 the RMT 600 TS will work in the same way as a standard (RMT LR, 571 202 480.) = No Tilt Sensor function.

The RMT 600 TS will normally be powered from the radio battery.

RMT 600 TS will automatically switch on when you start up the system in Robotic mode.

It is also possible to power the RMT with two built in standard batteries. This could be the case if the rod is extended more than the length of the connected cable or when working in Autolock mode. It will then work as a standard RMT without any tilt sensor function.

Bat low will in both cases be indicated with an irregular flashing of the red diode.

The RMT 600 TS has a specified range of 700 m in Robotic and up to 1000 m in Autolock, depending on weather conditions.

The pointing accuracy is better than 2mm at 200 meter (same as our other RMT's). Generally the pointing accuracy, under normal turbulence and light conditions, can be written  $\pm(1 \text{ mm} + 0.3 \text{ mgon (1")})$ , expressed in standard deviation.

*RMT 600 TS Part.no:*

571 204 240



fig 1-25



## RMT 604 / 606

The RMT 604/606 is a remote target to be used with Trimble 5600 series. The RMT 606 replaces 604 and includes an on/off switch and power connection through the shaft from the power stick.

The weight is only 250 gram (0,55 lbs). The range is 250-600 meters (800-1900ft) (depending on weather conditions) in both Autolock and Robotic.

The target consists of two parts:

1. Prism ring, functions as a reflector for the measuring signal.
2. RMT 606, active target that the tracker signal locks onto.



The prism ring contains seven 1/2" prisms positioned for 360 deg coverage.

The ring has a standard 5/8 UNC thread and can be mounted on any device such as RMT mini and sight point.

Prism ring Part.no: 571 204 312

The RMT 606 has ten LED positioned to cover 360 deg.

The RMT has a 5/8 thread in the bottom to be mounted on a range pole or signal pin.

*RMT 606 Part.no:*

571 204 610



## Rods

*fig 1-26*



### Telescopic rod - 571 181 090

Aluminium telescopic rod. The rod is graduated in cm/foot. Can be combined with 571 181 394 sight rod and 571 181 180 sight rod for RMT.

*Part.no:*

571 181 090

fig 1-27



### Telescopic rod - 571 126 088

Aluminium telescopic rod. The rod is graduated in cm/foot. Can be used with all Geodimeter reflectors and RMT's.

*Part.no:*

571 126 088

fig 1-28



### Telescopic rod - 571 126 098

Graphite telescopic rod. This is a lightweight telescopic rod with a 5/8 thread at the top. The rod is black, weighs only 690g and has graduations in both Meters and Feet.

The rod has a "cam lever" quick lock system to release and lock the telescopic section. The tightness can be adjusted with a hexagonal key (torx tool).

The bubble can also be adjusted with a hexagonal key.

The rod can be adjusted to have any length between 1,50m (4,92ft) and 2,57m (8.43ft).

The user can adjust the top screw so that the scale on the rod will match any target or GPS antenna. This is necessary because different targets or antennas have different dimensions, or a user may not have the height adapter available.

*Part.no:*

571 126 098

## Targets

*fig 1-29*



### Super prism standard

High precision prism for maximum range. Special coating for long lifetime.

For system 220, 400, 4000, 500, 600 & 5600 series.

*Part.no:*

571 125 021

*fig 1-30*



### Super prism sealed

High precision prism for maximum range. For hydrographic or other applications where the prism is used under severe conditions.

For system 220, 400, 4000, 500 600 & 5600 series.

*Part.no:*

571 126 070

*fig 1-31*



### Miniature prism

Precision prism.

For system 220, 400, 4000, 500 600 & 5600 series.

*Part.no:*

571 126 060

fig 1-32

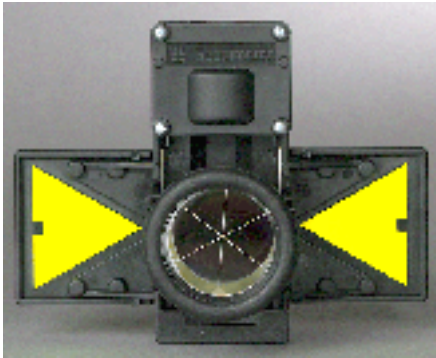

### Small tiltable reflector

For setting out and tachometry.  
 Tiltable over a range of  $\pm 35$  gon (31,5 degrees).  
 Fixed level bubble and locking ring for higher stability.  
 0 constant when mounted on all poles and signal pins produced by Spectra precision.  
 For system 500, 600 & 5600 series.

*Part.no:*  
 571 126 100

fig 1-33



### Large tiltable reflector

For setting out and tachometry.  
 Tiltable over a range of  $\pm 35$  gon (31,5 degrees).  
 Fixed level bubble and locking ring for higher stability.  
 0 constant when mounted on all poles and signal pins produced by Spectra precision.  
 For system 500, 600 & 5600 series.

*Part.no:*  
 571 126 110

fig 1-34



### Small tiltable reflector

For setting out and tachometry.  
 Tiltable over a range of  $\pm 35$  gon (31,5 degrees).  
 Fixed level bubble and locking ring for higher stability.  
 0 constant when mounted on all poles and signal pins produced by Spectra precision.  
 For system 400 & 4000.

*Part.no:*  
 571 126 150

fig 1-35



## Large tiltable reflector

For setting out and tachometry.

Tiltable over a range of +/- 35 gon (31,5 degrees).

Fixed level bubble and locking ring for higher stability.

0 constant when mounted on all poles and signal pins produced by Spectra precision.

For system 400 & 4000.

*Part.no:*

571 126 140

fig 1-36

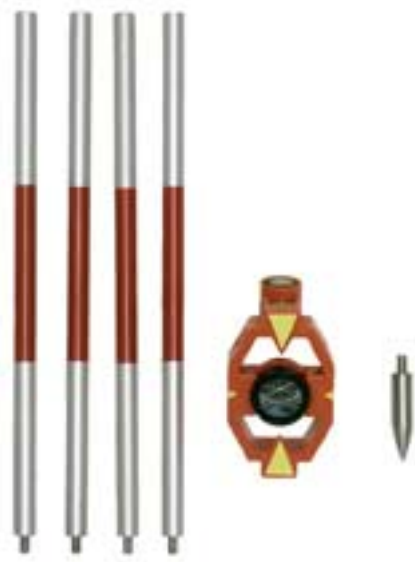

## Mini prism kit

Mini prism kit consisting of the following items:

- Tiltable 25,4 mm Mini Prism with holder and bubble
- 4 sections of signal pins, 300 mm
- 2 points, 50 mm

The prism constant is -18 mm, which means that the "star" of the prism is equal to the rotating point and the "star" can therefore be used when aiming towards the Target.

Please note that the Prism and the Sight markers shall be faced towards the Instrument, otherwise the prism constant of -18 mm will be incorrect.

When the 4 sections of the signal pins are screwed together you will have a rod 1200-mm high. The Mini Prism can be attached on the top or at the bottom of the rod.

With the Mini Prism and a point included the total Signal height of 1300-mm if placed on the top of the rod and 100-mm if placed at the bottom.

The Mini Prism can also be placed "in between" the signal pins in various combinations.

*Part no:*

571 126 273

## Tribrach

fig 1-37



### Tribrach - 571 900 680

Tribrach Geodolite with optical plummet.

fig 1-38



### Tribrach - 571 905 560/2

Tribrach Geodimeter with optical plummet.

fig 1-39



### Tribrach - 571 908 823

This tribrach is equipped with a laser unit instead of the conventional optical plummet.

With this laser tribrach it will be possible to plumb a point both downwards and upwards. Note! This product is not design to be a high precision plumb device.

This laser tribrach is 100% compatible with the standard tribrach (571 905 560) except from the plumbing device. The instrument height meter (571 125 728) will work in normal way to this laser tribrach.

#### *Caution!*

Although the built-in laser source is a low power type some precaution should be observed. Output power of the laser light emitted is <math><1\text{mW}</math> in both directions.

Do not stare into beam either with naked eyes or with optical devices! This may seriously injure your eyes.

#### *Specification:*

Laser wavelength:	645 - 665 nm
Power of the module:	nom. 2,5mW
Output light power/ray:	<math><1\text{mW}</math>
Operating temp. range*:	0°C to +40°C
Transport temp. range:	-30°C to +50°C
Battery:	3x V 13 GA (Varta) or equivalent.
Operation time:	1,5 hours at 20°C (68F)

## Tripod

### Tripod heavy duty - 571 126 275

*fig 1-40*



The heavy duty tripod 571 126 275 replaces 571 126 206.

High accuracy tripod especially made for servo driven instruments.

Made in high quality wood and aluminium with cast iron feet and steel tips.

Holder for battery and a 5/8" thread for the tribrach.

The weight is 8.0 kg (17,6 LB) and the length is 1.12 m (3.67 ft) during transportation.

Supports Spectra precision instrument height meter 571 125 728.

*Part.no:*

571 126 275



## GPS Antennas

fig 1-41



### Compact antenna L1

This is a single frequency active antenna, it has an integrated pre amplifier of 12 dB.

The antenna is supplied with power from the receiver.

The antenna has an N-type connector.

*Compact antenna L1 Part.no:*

571 212 240

### Geodetic antenna L1

fig 1-42



This is a single frequency active antenna, it has an integrated pre amplifier of 12 dB.

The antenna is supplied with power from the receiver.

The antenna has an N-type connector.

*Geodetic antenna L1 Part.no:*

571 212 236

fig 1-43



### Compact antenna L1/L2

This is a dual frequency active antenna, it has an integrated pre amplifier of 12 dB.

The antenna is supplied with power from the receiver.

The antenna has an N-type connector.

*Compact antenna L1/L2 Part.no:*

571 212 430

## Geodetic antenna L1/L2

*fig 1-44*



This is a single frequency active antenna, it has an integrated pre amplifier of 12 dB. The antenna is supplied with power from the receiver. The antenna has an N-type connector.

*Compact antenna L1/L2 Part.no:*

571 212 238

## Choke ring antenna L1/L2

*fig 1-45*



This is a single frequency active antenna, it has an integrated pre amplifier of 12 dB. The antenna is supplied with power from the receiver. The antenna cover is not shown in picture.

The antenna has an N-type connector.

*Choke ring antenna L1/L2 Part.no:*

571 908 273

## Mini geodetic antenna L1

*fig 1-46*



This is a single frequency active antenna, it has an integrated pre amplifier of 12 dB.  
The antenna is supplied with power from the receiver.  
The antenna has a TNC-type connector.

*Mini geodetic antenna L1 Part.no:*

571 212 774

*Adapter TNC/N type connector Part.no:*

571 908 372

## Mini geodetic antenna L1/L2

*fig 1-47*



This is a dual frequency active antenna, it has an integrated pre amplifier of 12 dB.  
The antenna is supplied with power from the receiver.  
The antenna has a TNC-type connector.

*Mini geodetic antenna L1/L2 Part.no:*

571 212 777

*Adapter TNC/N type connector Part.no:*

571 908 372

## GPS/GLONASS antenna L1

*fig 1-48*



This is a single frequency GPS/GLONASS active antenna, it has an integrated pre amplifier of 12 dB.

The antenna is supplied with power from the receiver.

The antenna has a TNC-type connector.

*GPS/GLONASS antenna L1 Part.no:*

571 212 791.

*Adapter TNC/N type connector Part.no:*

571 908 372.

## 2. Technical description

### Holders

#### ACU Holder

Connect a ACU and batteries and the system is ready to use! No cables needed. It can be used on all rods with dimensions from 20 mm up to 45 mm.

*fig 2-1*



The ACU Holder includes two boards:

- CAP2 board
- BCB2 board

## CU Holder

Connect a battery and a radio and the system is ready to use! No cables needed. It can be used on all rods with dimensions from 20 mm up to 45 mm.

fig 2-2



The CU Holder includes two boards:

- CAP board, same board as Holder for CU & radio/RS232 [see page 2-3](#)
- TBD board

fig 2-3

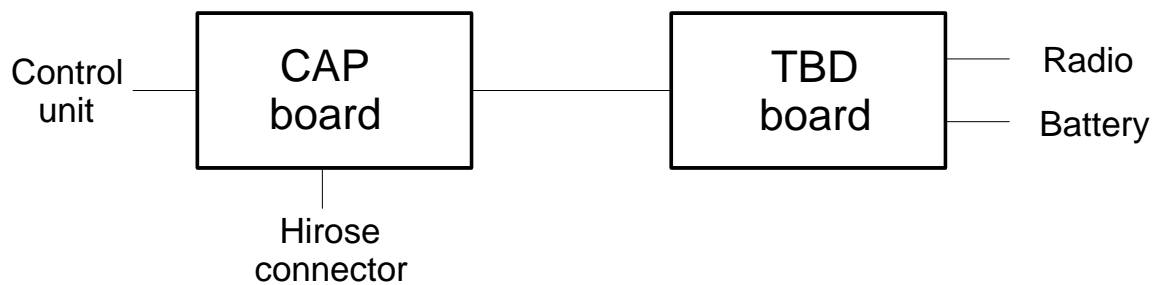

## Holder for CU & radio/RS232

To communicate with the RMT 600 TS, a control unit holder with an extra RS232 port and a system cable connected up to the RMT must be used.

The holder is mounted to a measuring pole.

fig 2-4

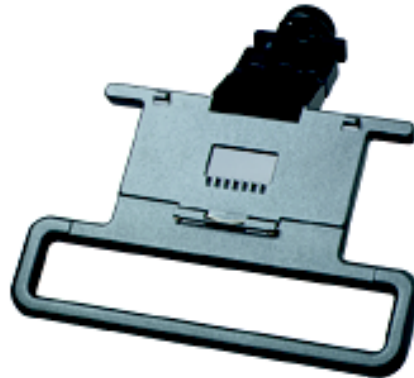

## CAP board

The board includes the following functions:

- Panel detection
- Power/Battery low
- RS232 conversion
- ON/OFF timing
- ESD protection
- Over current detection
- Connection to keyboard
- Hirose connectors

fig 2-5

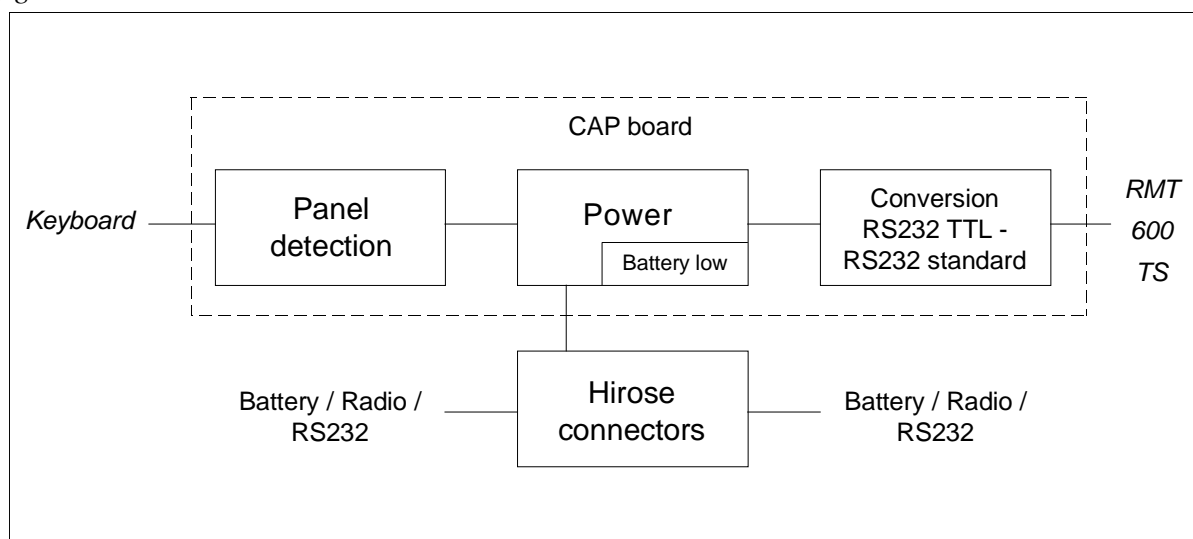

#### Panel detection

A circuit to detect the presence of the keyboard mounted to the holder shuts off the holder when the keyboard is removed.

#### Power/Battery low

Distributes power to the keyboard and RMT 600 TS. The Holder will detect the battery low level last in the system, i.e. after the CU and GDM. The function to detect battery low is temperature compensated. At 20° C it is 9,4 V. Over current protection 1.4 A.

#### RS232 conversion

To be able for CU600 to communicate with the RMT 600 TS the signals are converted from RS232 TTL levels from the CU600 to RS232 standard levels to the RMT 600 TS. This is done on the CAP board.

#### Connection to keyboard

A seven numbered spring connector communicates with the keyboard.

#### Hirose connectors

Power/ RS232 or a radio can be connected to the two Hirose connectors on the back of the holder.



# RMT

## RMT 600/600 LR

### Blocks

The Remote target consists of these five main blocks:

- Battery off and Switch converter
- Internal battery indicator
- On/Off logic
- Oscillator
- Infrared LED driver
- Laser safety

fig 2-6

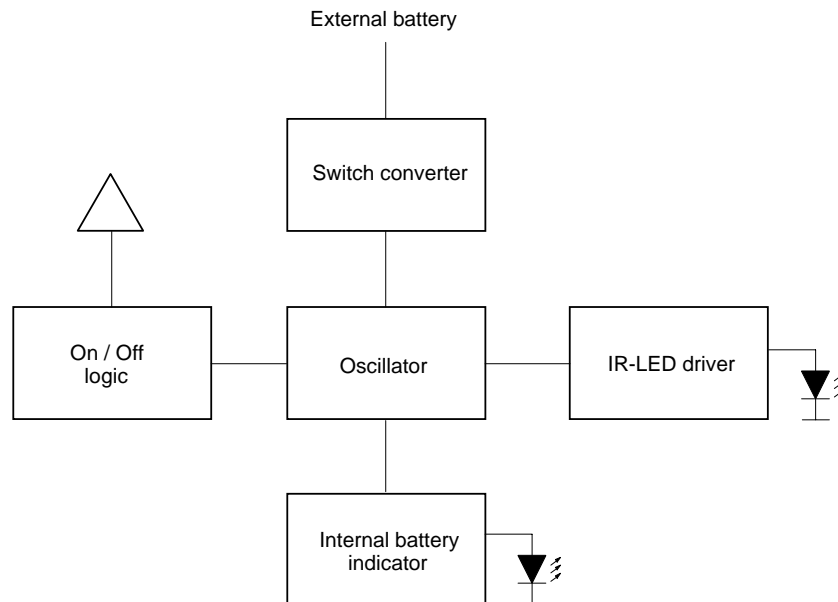

### On/off logic

When the push-button on the front is operated, the on/off logic produces a signal which is used to switch the Remote target on or off.

### Battery off and Switch converter

In the Switch converter block, +12 V from an external power source are converted into +3 V which is used in the Remote target. The Switch converter also has a bat off function which eliminates the risk of damage when discharging an external battery.

### Oscillator

The oscillator supplies signal to the IR LED driver.

### Infrared LED driver

This block is driving the infrared transmitter LED with a precision regulated current.

### Laser safety

For laser safety reasons the RTG/RTLRL board contains an extra function, ESF (Extra Safety Feature). This is to prevent the transmitter diode from emitting at too high power level at a "single fault" occasion.

On early versions the ESF function is on an extra board.

### STD vs. LR

On the RMT 600 LR, the transmitting diode is changed from standard to a long range version.

## RMT SLR

### Target recognition setting

The target can be set to four different frequencies so that the instrument can recognise and identify four different targets.

The channels are set with a switch on the RMTSL board inside the RMT SLR.

### Performance

Item	Action	Performance	Result	Notes
1	Remove lid	Unscrew the six screws holding the lid to the chassis and remove lid	The switch on the RMTSL board is now accessible.	
2	Set frequency	Turn the switch S1 to the selected channel.		See channel table. See fig 2-7

fig 2-7

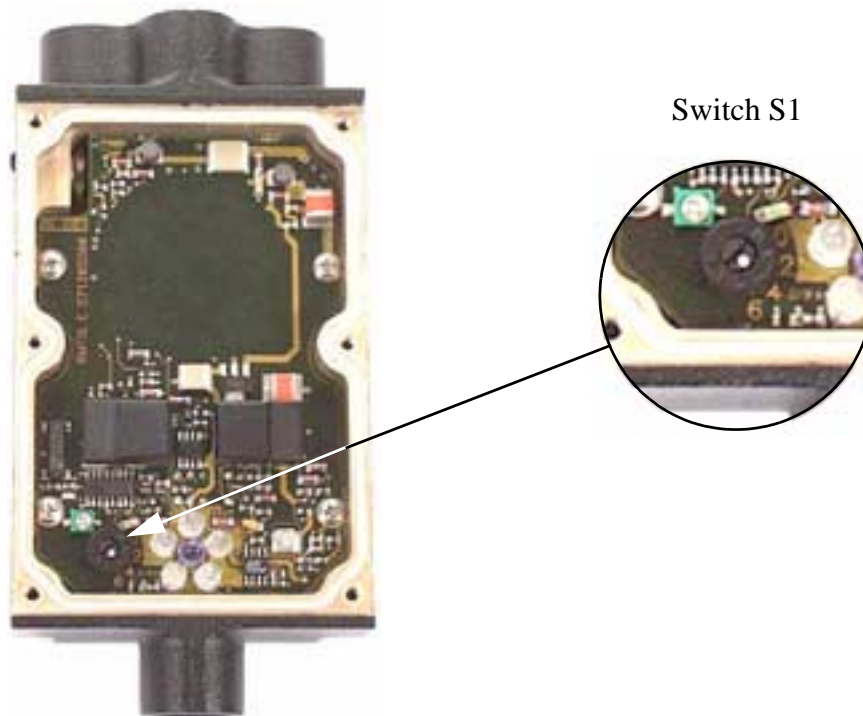

3	Fit lid	Fit the lid to the chassis and secure with six screws.		Make sure that the seal is in place.
---	---------	--	--	--------------------------------------

## Channel table

Channel	Frequency
Channel 0	6250,00 Hz
Channel 2	6944,44 Hz
Channel 4	7812,50 Hz
Channel 6	8928,57 Hz

Tracker target ATS

Tracker target Plus

Tracker target 600

Super RMT

RMT 600 ATS (Hirose)

RMT 600 ATS (Canon)

RMT 600 ATS multi channel

RFCM Board

Laser safety

The RFCM board, mounted in it's housing, is a Class 1 laser product. The emitted light is typically 1,1-1,2 mW, measured just outside the glass with a 7 mm diameter aperture.

In a single fault condition, current limiters will prevent radiation in excess of approx. 1,5 mW. The limit for laser Class 1 is 2 mW.

Intensive light sources, like the RFCM board, must always be handled with respect. Never look into the light emitting diodes when the board is powered up outside the housing

Blocks

The RFCM board (consists of these main) function blocks:

- Protection against reverse polarity.
- ESD protection
- Remote off control
- Voltage regulators for +9,6 V and +5,0 V.
- Current limiters for LED safety
- Battery low detect
- Oscillator
- Frequency divider with selector for 4 different modulation frequencies
- Current regulators and modulation drivers
- Driver for visible red LED's.
- Patch field for configuration of the board to different systems (600/4000).

The board can be powered with an input voltage of 10,5 V to 30 V DC.

fig 2-8

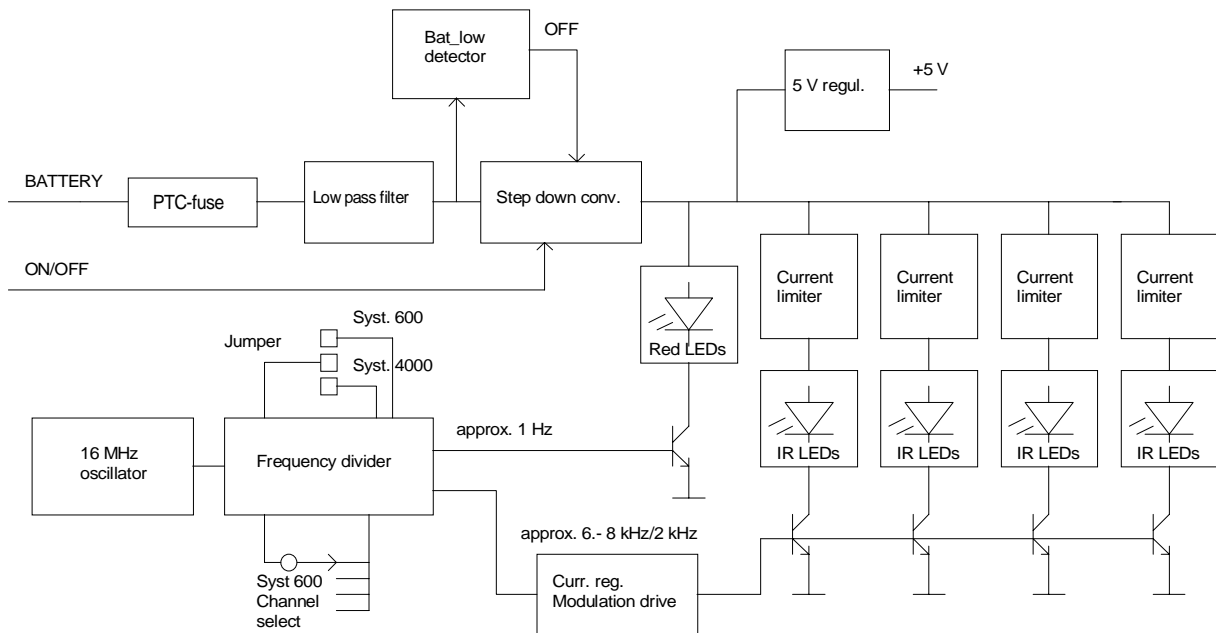

### RFCM Board configuration

The RFCM board can be used for all targets (except for the Super RMT) if the jumpers are set according to the configuration table below and a new cable for the connector is fitted.

#### Tracker target ATS & Tracker target Plus:

Modulation frequency 1,95 kHz  
 R7,R9 and switch S1 not mounted  
 Solder connection in patch field JP1 & JP2

#### Tracker target 600, Super RMT & RMT 600 ATS (Hirose & Canon)

Modulation frequency 7,8125 kHz  
 R7, R9 mounted and switch S1 not mounted  
 Solder connection in patch field JP3

#### RMT 600 ATS Multi channel

Modulation frequency 6,25 kHz, 6,9444 kHz, 7,8125 kHz and 8,9286 kHz  
 R7, R9 and switch S1 mounted  
 No connections in patch field

Configuration table

Target type	JP1	JP2	JP3	R7	R9	Switch S1
Tracker target ATS	Yes	Yes	No	No	No	No
Tracker target Plus	Yes	Yes	No	No	No	No
Tracker target 600	No	No	Yes	Yes	Yes	No
RMT 600 ATS (Hirose)	No	No	Yes	Yes	Yes	No
RMT 600 ATS (Canon)	No	No <td Yes	Yes	Yes	No	
RMT 600 ATS Multi channel	No	No	Yes	Yes	Yes	Yes

fig 2-9

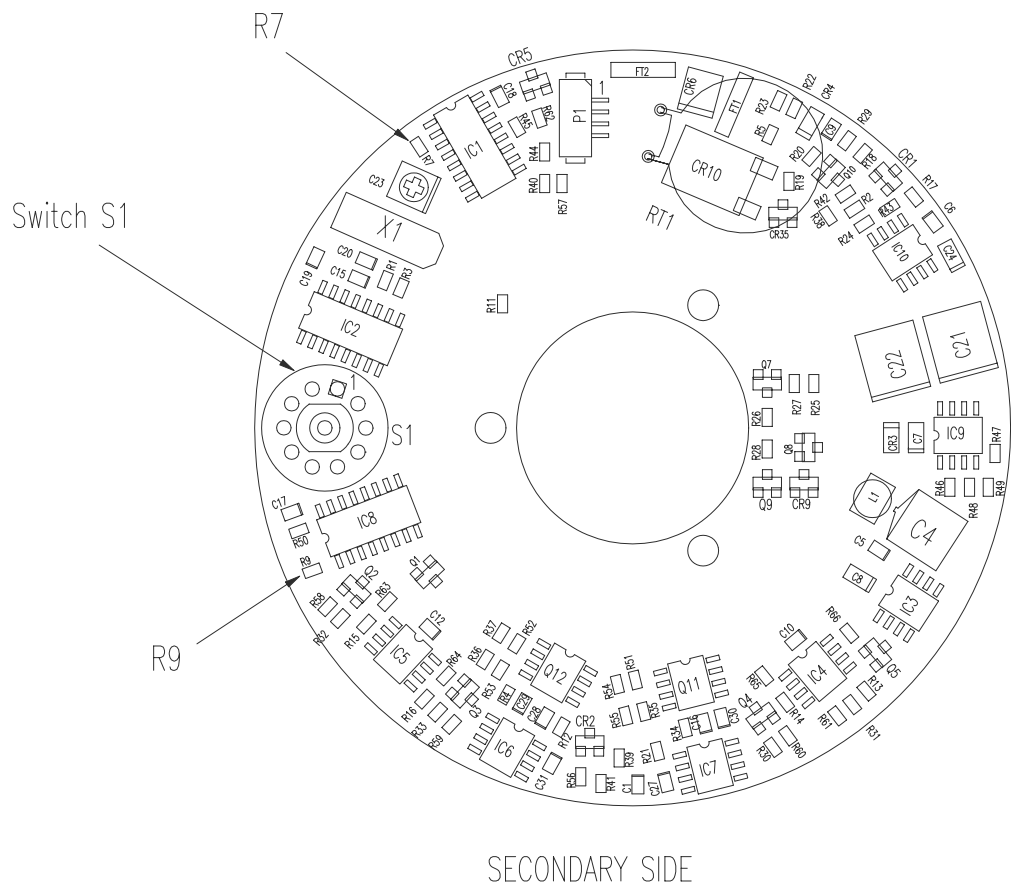
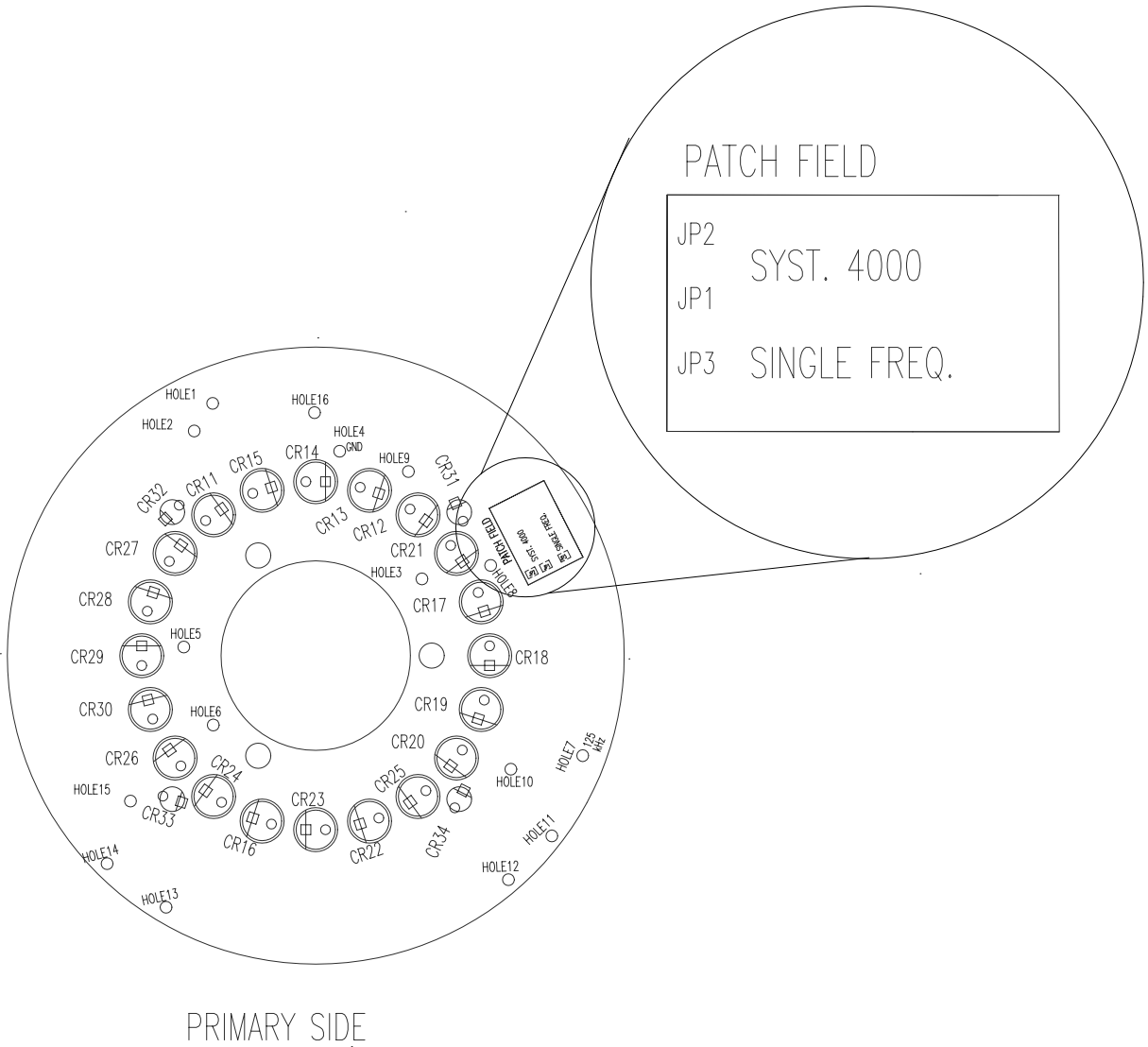

fig 2-10





## RMT 600 TS

*fig 2-11*

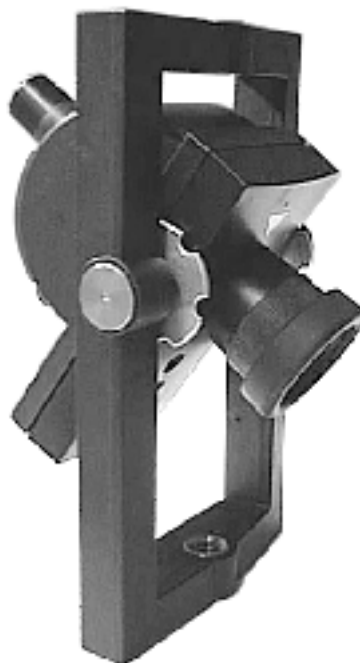

The RMT 600 TS has the same main function as the RPU 4000.

To operate the RMT 600 TS:

- Calibration of the angle sensor prior to use (indicated in the display if necessary): tilt the RMT approx. 25 deg.
- Aim the RMT by using the coarse sight towards the Geodimeter.
- Press the A/M button to start the search.
- The RMT will send the vertical angle via the radio link to the Geodimeter.
- The instrument recalculates the angle and tilts the telescope to the corresponding vertical angle. It starts to search  $\pm 30$  gon horizontally.
- If the target is not found, it will continue to search through the rest of the window horizontally and then search the full circle.
- If the target still is not found the Geodimeter will to start to search spirally in the search window. To break the search press the CL (arrow left) key.

Note! RMT 600 TS needs to be combined with the Holder for keyboard unit / RS232, 571 204 242 and cable connections. Control unit software of version 632-05.00 or higher is also required.

### General

The RMT consists of the following units:

- Transmitter IR diode

- Angle sensor
- Holder for prism
- FRT board
- Battery holder
- Coarse sight
- Indicator LED

fig 2-12

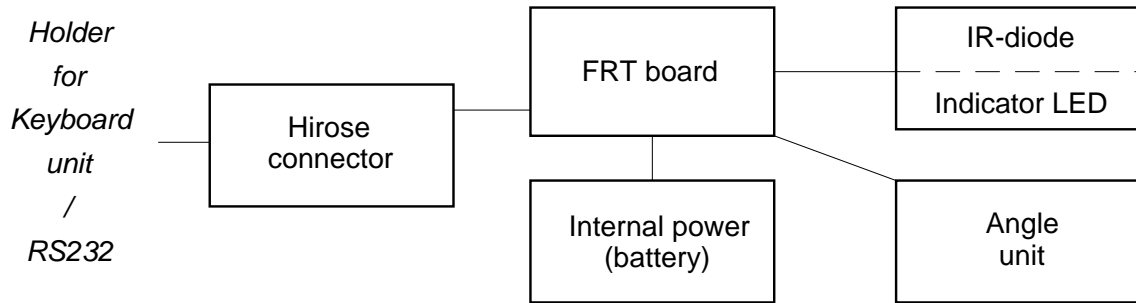

Transmitter IR diode

The RMT transmits at the same frequency as other RMT's, 8 kHz. The signal is received by the quadrature detector in the tracker unit.

The IR LED operates in laser class 1. The width of the beam is 15° deg.

Angle unit

fig 2-13



The angle sensor in the RMT 600 TS is a incremental inclinometer with an index pulse in the plumb line. The angle sensor will give an angle reading with respect to the plumb line.

Function

Inside there is a disc mounted to an axis by two ball bearings. A weight causes it to follow the source of gravity. The disc is magnetically damped and has a radial pattern of 3600 lines along the outer edge. These are detected by a LED source and a

detector diode generating two pulse trains, phase shifted 90 deg in relation to each other depending on direction of rotation.

To detect the orientation of the sensor an index pulse gives reference to the plumb line.

### Calibration

A calibration via SST is made at production / service to find the absolute angle, see the SST manual.

Prior to use, the user must tilt the RMT 600 TS down to pass the plumb line to generate an index pulse for the angle subsystem in the FRT.

### Holder for prism

A miniature prism 571 126 060 is mounted to reflect the distance measuring signal to the Geodimeter

### FRT board

The FRT board consists of the following blocks:

- Processor
- Communication/RS232
- Power/Battery low function
- +12V / +3V switching
- Power ON/OFF switch
- Drive for IR-diode/LED indicator
- Angle subsystem

fig 2-14

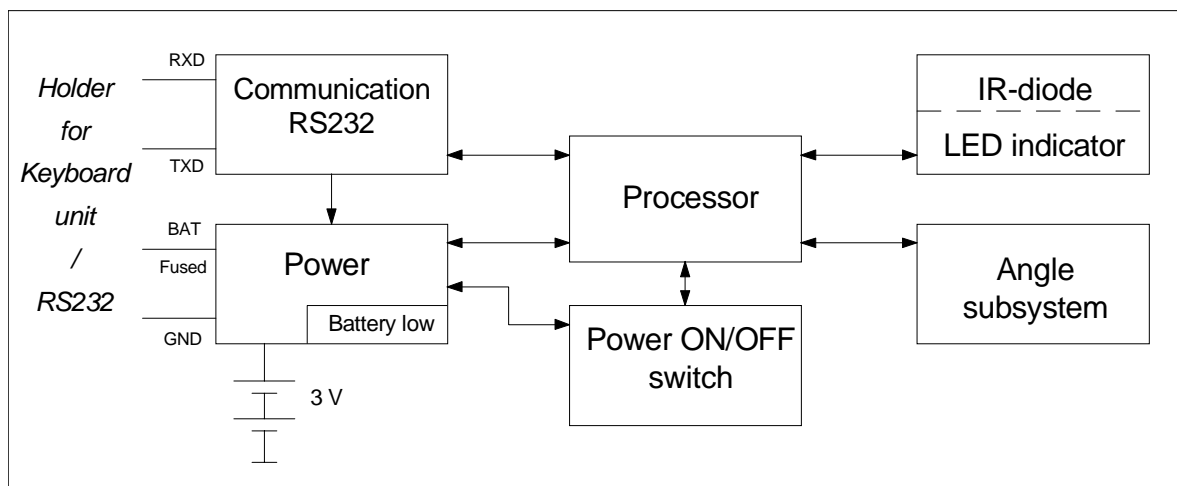

### Processor

A 87C51FA processor with a 8 kB memory for a program is used. A serial EEPROM is used to store the calibration value for the angle sensor.

### Communication/RS232

RS232 communication to the *Holder for Keyboard Unit / RS232*.

### Power/Battery low function

Power to the RMT 600 TS can be fed from an external 12 V battery or from two 3 V AA (LR6) internal batteries.

Battery low is detected between 9.7 to 10.3 V.

+5 v is generated on the FRT board by step down (+12V)/step up (+3V).

### +12V / +3V switching

If the +12V is removed the RMT 600 TS will switch to internal power (+3V), but the angle sensor will not be active. The sensor will be activated if the +12V is connected again.

**NOTE:** The index pulse must be generated as the angle sensor is switched on.  
If there is no internal power the RMT will be switched off if the +12V is removed.

### Power ON/OFF switch

The RMT 600 TS can be powered on via a break on the serial channel or a press on the ON/OFF button.

### Drive for IR-diode/LED indicator

The FRT board includes protection for single fault condition, causing excessive light output from the IR diode.

### Angle subsystem

The signals from the angle sensor are converted to a COUNT and DIRECTION signal. These and the index pulse are used by the processor to calculate the vertical angle.

### Battery holder

The RMT 600 TS can be powered by two 3 V AA (LR6) batteries, if the user wants to use the RMT high on a pole to avoid using long cables from an external battery.

**NOTE:** The angle sensor is not active in this mode, only the transmitter diode.

### Coarse sight

The coarse sight is used to aim the RMT towards the Geodimeter to get the correct search angle as there are no ocular devices on the RMT.

### Indication LED

The diode flashes normally with a rate of 2 Hz. The red LED indicates active IR-diode. Unsymmetrical repetition rate indicates low internal battery (< 1,9V).

## RMT 604 / 606

### Service

The circuit board, MOD board in the RMT 606 is also compatible with the RMT604. When replacing the board in the 604 mounting of a 0  $\Omega$  resistor must be made, *see fig. 4-6 on page 4-6.*

### Range

300 - 500 meters depending on conditions.

### “Locking on angle”

360 deg horizontal +/- 15 deg vertical.

### Power

12 V DC using standard system cables and Hirose connectors. Max voltage is 14 V DC.

### Current consumption

150 mA at 12 V.

### Battery low

A green LED will start to flash with 4 Hz when the supply voltage falls below 11,5 V.

The RMT will shut off at 10,5 V.

### Laser class

The RMT is not laser class specified. Even at a single fault the RMT will not exceed the limit of class 1.

### Visible LED

A green visible LED flashes with a rate of 2 Hz in normal operation and with 4 Hz at battery low.

### Size, total

Diameter: 50 mm  
Height: 135 mm to prism centre (total length: 166,5 mm)

### Size, prism ring

Diameter: 45 mm (Handle)  
Height: 31,5 mm to prism centre (total length: 63 mm)

**Size, RMT mini**

Diameter: 50 mm  
Height: 103,5 mm

**Weight**

Total: 240 g  
Prism ring: 90 g  
RMT mini: 150 g

**Connecting threads**

Standard 5/8-11 UNC

**Prism constant**

+2 mm, marked on the prism ring.

### 3. Mechanical description

#### RMT

RMT 604 - 571 204 310

RMT 606 - 571 204 610

#### Removal

#### Tools & Equipment

Description	Part number
Spanner, 13 mm	
Spanner, 19 mm	
Spanner, 21 mm	

#### Performance

Item	Action	Performance	Result	Notes
1	Remove the shaft locking nut.	Use a 19 and 21mm spanner, one holding the nut and one the centre shaft.		Heat up the locking nut with a hot air gun to make removal easier.

fig 3-1



Performance

Item	Action	Performance	Result	Notes
------	--------	-------------	--------	-------

- 2 Remove centre shaft sealing ring, lid and upper glass sealing ring.

fig 3-2



- 3 Remove glass and lower glass sealing ring.

fig 3-3





Performance

Item	Action	Performance	Result	Notes
4	Remove the reflector.	Remove the reflector locking nut.		Use a 13 mm spanner.

fig 3-4



5	Remove the centre shaft.	Disconnect the cable from the centre shaft and remove the shaft.		RMT 604 centre shaft is removable without the cable.
---	--------------------------	--	--	--

fig 3-5



Performance

Item	Action	Performance	Result	Notes
6	Remove MOD board.	Remove cable from: <ul style="list-style-type: none"> <li>• Hirose connect</li> <li>• on/off switch</li> </ul>		RMT 604 MOD board has only one cable connected, a soldered cable from Hirose connector.

fig 3-6

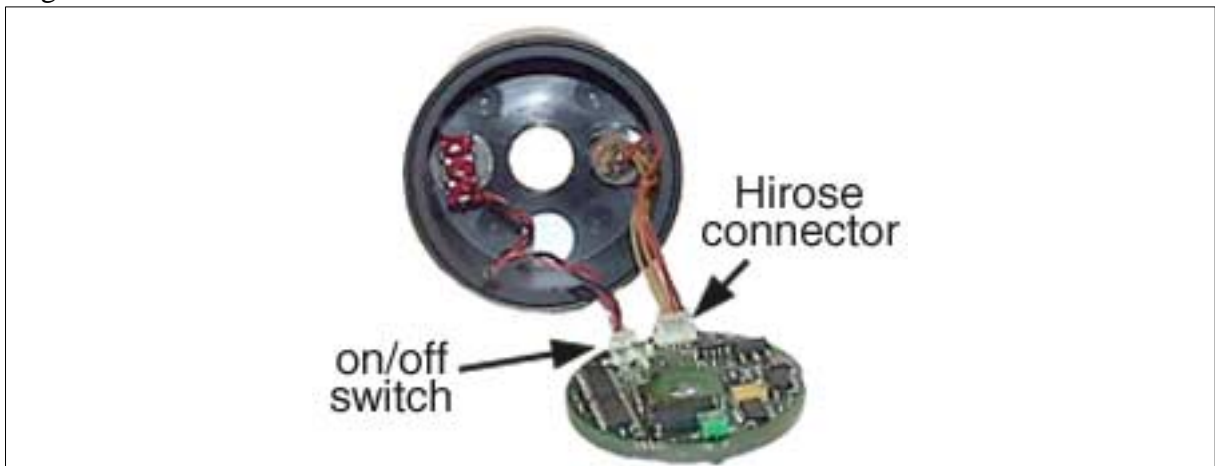

- 7 Remove the Hirose connector and on/off switch.

fig 3-7



Assembling

Tools & Equipment

Description	Part number
Spanner, 13 mm	
Spanner, 19 mm	
Spanner, 21 mm	
Loctite 243	571 908 266
Silicone, 3140	571 908 117

Performance

Item	Action	Performance	Result	Notes
1	Mount Hirose connector and on/off switch.	1. Seal the back of the connector with silicone. 2. Mount the locking washer and nut. 3. Mount the switch, use the washer and nut.		Apply silicone 3140 around the connector and the cables.

fig 3-8



Performance

Item	Action	Performance	Result	Notes
2	Mount the MOD board.	Connect cables from: <ul style="list-style-type: none"> <li>• Hirose connector</li> <li>• On/off switch</li> </ul>		<b>RMT 604 ONLY</b> Replace the Hirose connector incl. cable (R71 207 126) and mount a 0 Ω resistor, <i>see fig 4-6 on page 4-6.</i>

fig 3-9

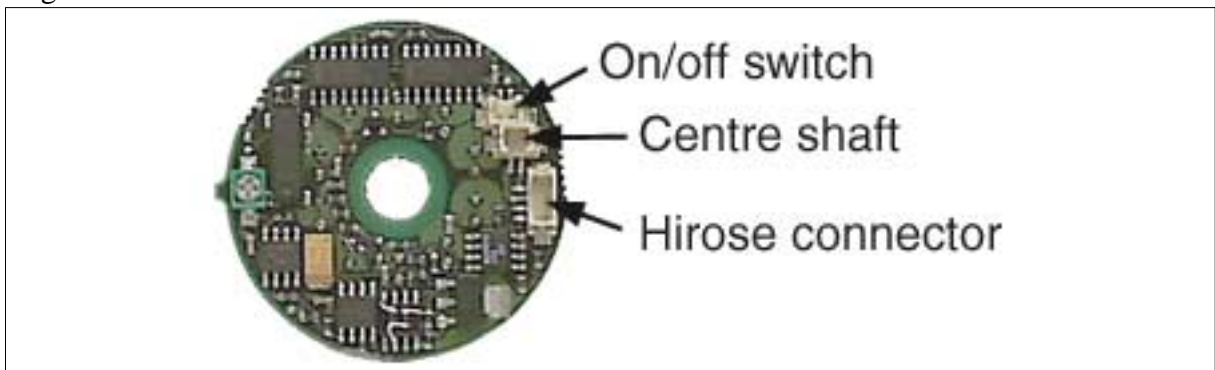

- |   |                         |   |
|---|-------------------------|---|
| 3 | Mount the centre shaft. | <ol style="list-style-type: none"> <li>1. Position the board according to orientation.</li> <li>2. Make sure the o-ring is mounted in the centre shaft.</li> <li>3. Mount the cable from the Centre shaft to MOD board, <i>see fig 3-9.</i></li> <li>4. Mount the shaft.</li> </ol> |
|---|-------------------------|---|

fig 3-10



Performance

Item	Action	Performance	Result	Notes
4	Mount the reflector.	Use a 13 mm spanner to lock the nut.		

fig 3-11



5	Mount glass sealing rings, glass, lid and shaft sealing ring.	Place one glass sealing ring in the base and the other in the lid.		
---	---	--	--	--

fig 3-12



Performance

Item	Action	Performance	Result	Notes
6	Mount the shaft locking nut.	1. Apply loctite 243 on the centre shaft threads. 2. Use a 19 and a 21 mm spanner to lock the nut towards the centre shaft.		Tighten the locking nut enough so it will not loosen when the prism ring is removed from the RMT.

fig 3-13



## Prism ring - 571 204 312

### Removal

#### Tools & Equipment

Description	Part number
Spanner, 19 mm	

#### Performance

Item	Action	Performance	Result	Notes
1	Remove the handle.	Remove the knob by hand.		

fig 3-14



Performance

Item	Action	Performance	Result	Notes
2	Remove the upper spacer from the lower spacer.	Use two 19 mm spanners, one holding the upper spacer and one the lower spacer.		Heat up the upper spacer with a hot air gun to make removal easier.

fig 3-15





Performance

Item	Action	Performance	Result	Notes
3	Remove the prism holder and prisms.			When replacing one or more prisms also replace the two prism holders to make sure the prisms are held in place.

fig 3-16



Assembling

Performance

Item	Action	Performance	Result	Notes
1	Mount the prisms.	Place seven prisms in the prism holder and add silicone to fix the prisms. Mount the second holder.		When replacing one or more prisms also replace the two prism holders to make sure the prisms are held in place.

fig 3-17

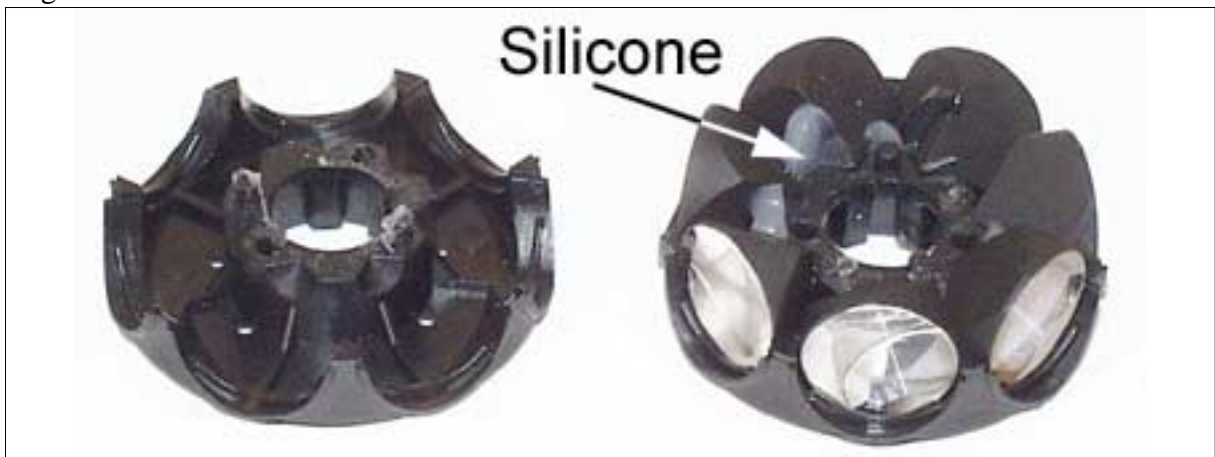

Performance

Item	Action	Performance	Result	Notes
2	Mount the upper and lower spacer.	1. Mount the prism assembly on the lower spacer. 2. Apply loctite 243 on the threads of the upper spacer. 3. Use two 19 mm spanners to lock the two spacers towards each other.		Tighten the spacers enough so they will not get loose when the prism ring is removed from the RMT.

fig 3-18



### Performance

Item	Action	Performance	Result	Notes
3	Mount the handle.	Use the hand to mount the knob.		The handle should be removable by hand.

fig 3-19



## RMT SLR - 571 204 360

### Removal

#### Performance

Item	Action	Performance	Result	Notes
1	Remove lid	Unscrew the six screws holding the lid to the chassis.		
2	Remove batteries			
3	Remove RMTSL board	Unscrew the four screws holding the RMTSL board to the chassis and remove the board.		<i>See fig 3-20.</i>

fig 3-20

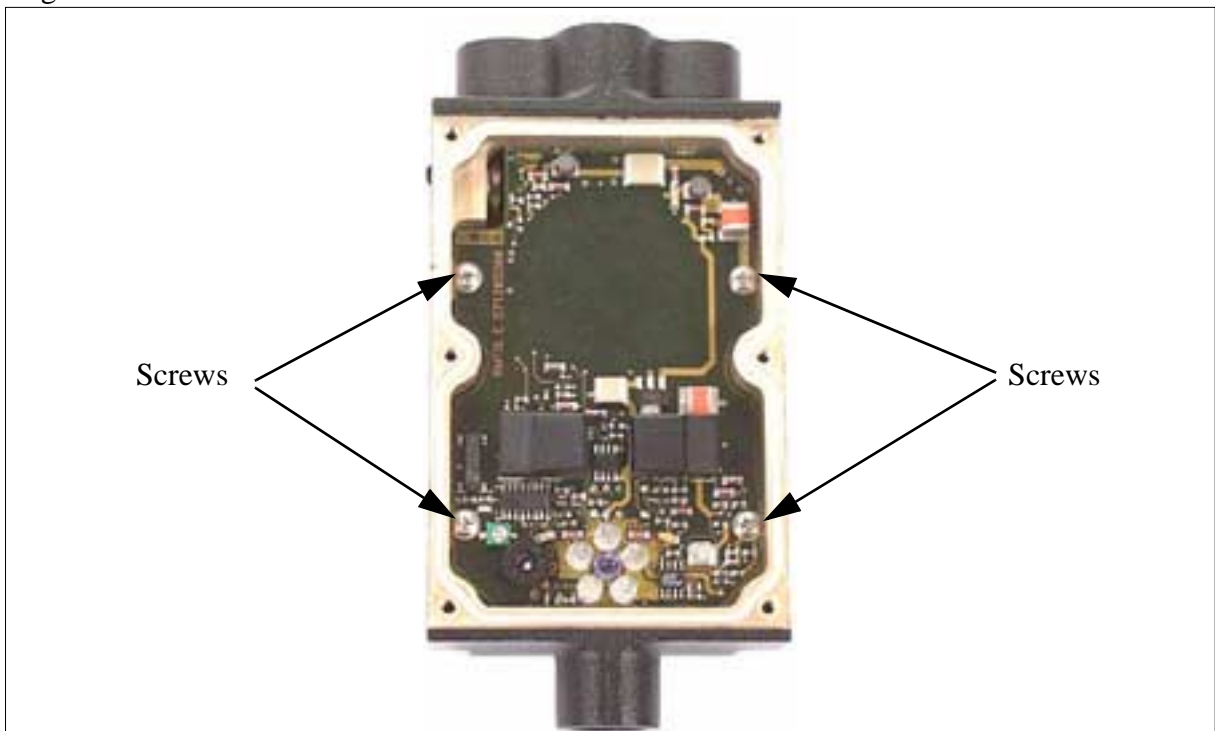

Performance

Item	Action	Performance	Result	Notes
4	Disconnect cable/cables	Disconnect the cable between the Hirose connector/connectors and the RMTSL board.		The first version of the RMT SLR has only one cable, the second two cables. <i>See fig 3-21.</i>

fig 3-21

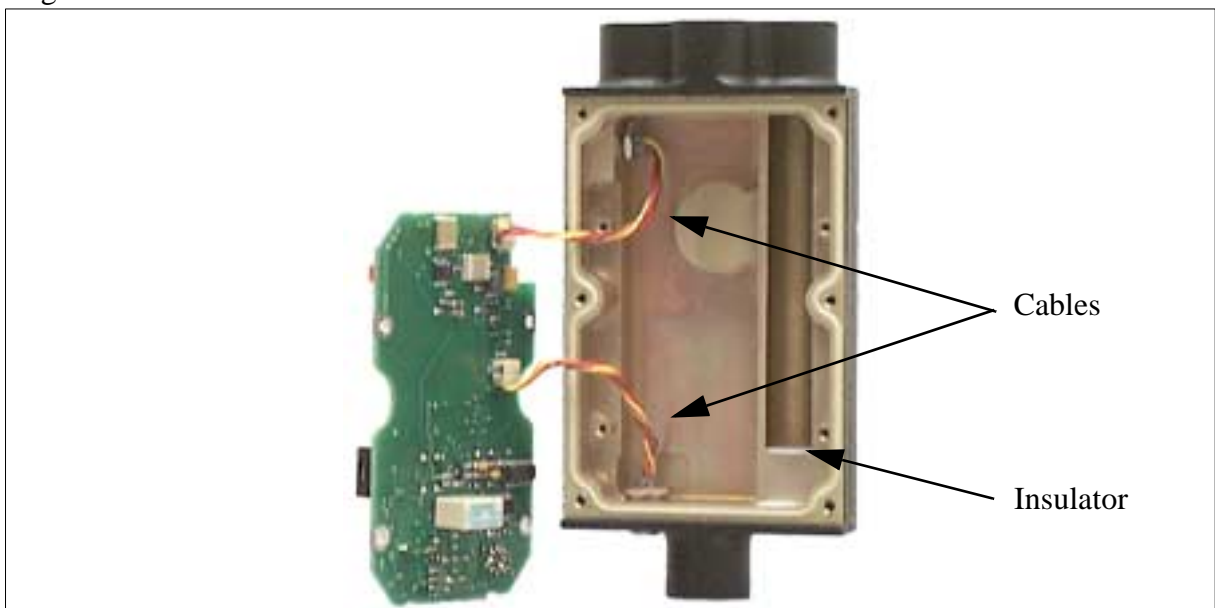

5	Remove insulator	Remove the insulator from the battery compartment.		<i>See fig 3-21.</i>
---	------------------	--	--	----------------------

Assembling

Performance

Item	Action	Performance	Result	Notes
1	Connect cable/ cables.	Connect cable between the RMTSL board and the Hirose connector.		
2	Fit insulator	Fit the insulator in the battery compart- ment.		
3	Fit RMTSL board	Fit the RMTSL board and secure the board to the chassis with four screws.		Note! Make sure that the battery con- nector is placed above the insulator when the board is fit- ted so that it does not short circuit to the chassis, <i>see</i> <a href="#">fig 3-22</a> .

fig 3-22

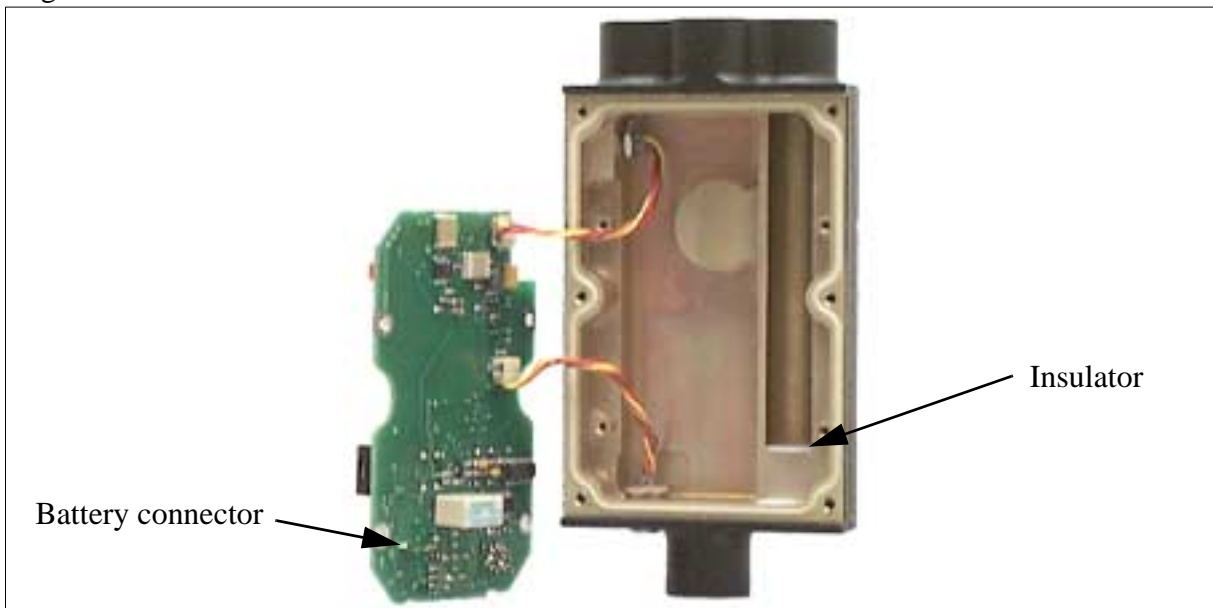

## Performance

Item	Action	Performance	Result	Notes
4	Fit lid	Fit the lid to the chassis and secure with six screws.		Make sure that the sealing is in place.
5	Fit batteries	Fit the internal batteries.		



Tracker target ATS - 571 181 874

Tracker target Plus - 571 181 586

Tracker target 600 - 571 181 774

Super RMT - 571 181 870

RMT 600 ATS (Hirose) - 571 233 020

RMT 600 ATS (Canon) - 571 233 025

RMT 600 ATS multi channel - 571 233 035

## Removal

### Tools & Equipment

Description	Part number
Assembly tool RMT	T71 601 120

fig 3-23



fig 3-24

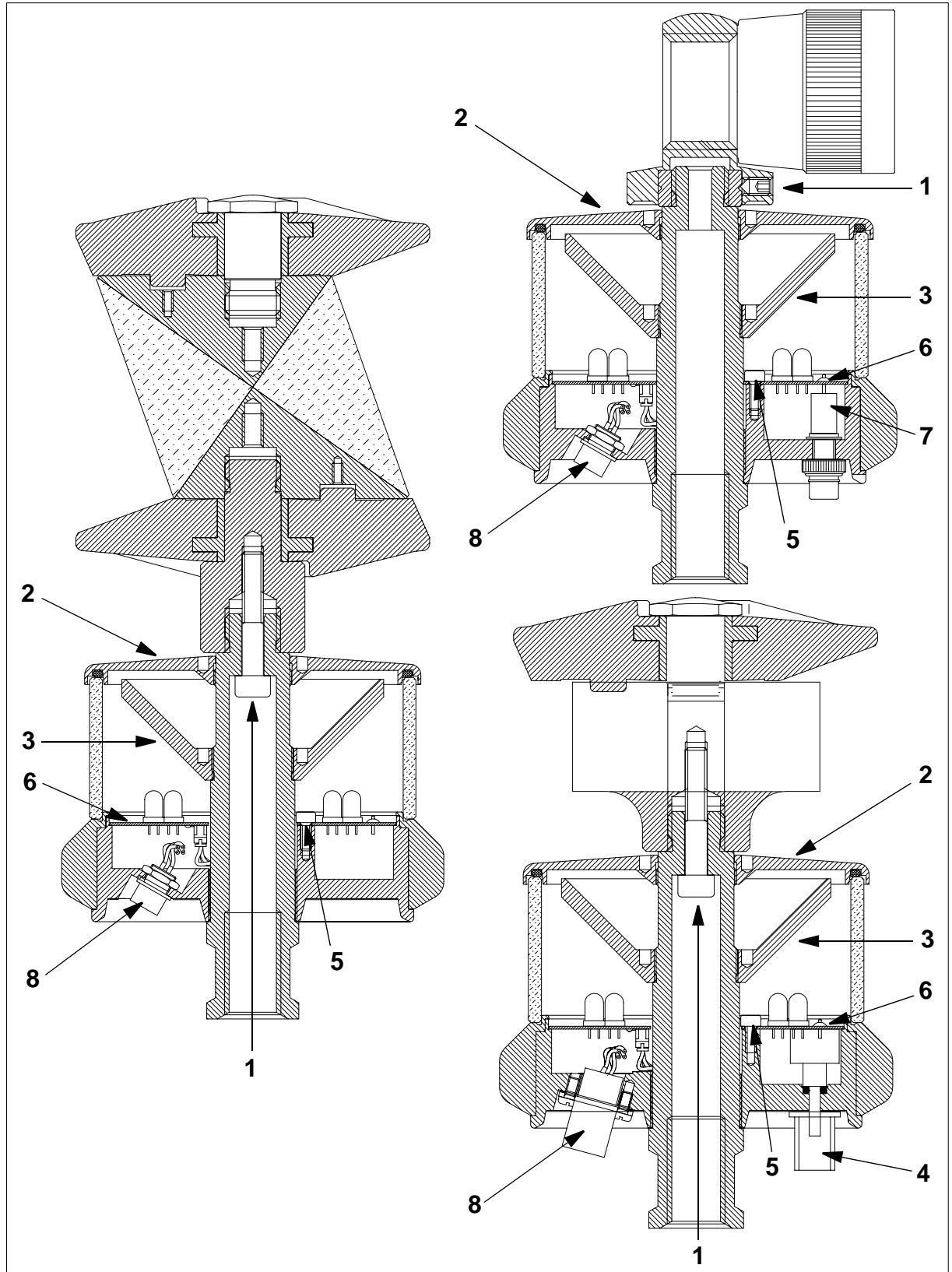

### Performance

Item	Action	Performance	Result	Notes
1	Remove the prism ring or prism holder.	Unscrew the screw with an allen key.		The screw is locked with Loctite.
2	Remove the lid.	Use the tool T71 601 120.		Use of a hot air blower to warm up the lid will help the removal.

fig 3-25



3	Remove the mirror.	Use the tool T71 601 120.		
4	Remove channel switch knob.			Only multi channel RMT.
5	Remove the screws holding the RFC / RFCM board.	Unscrew the three screws.		Loctite is used to lock the screws.
6	Remove the RFC / RFCM board.	Lift up the board remove the cable and board.		The board is secured with pliobond on four points.

### Performance

Item	Action	Performance	Result	Notes
7	Remove the switches from the RFC board.	Resolder the switches.		Only for RMT Super.
8	Remove GND connection.	Remove the connectors GND connection.		
9	Remove the connector.	<p><i>Cannon:</i> The connectors are held by four screws.</p> <p><i>Hirose:</i> Remove the locking ring from inside the RMT.</p>		

fig 3-26

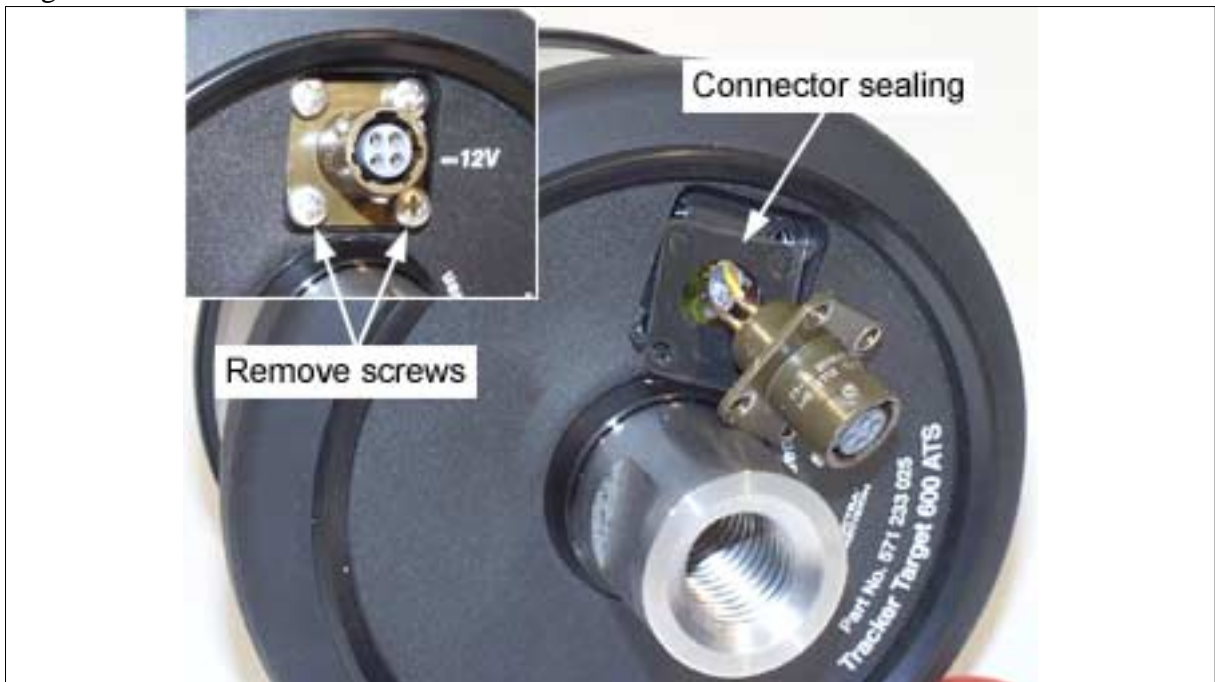

## Assembling

## Tools &amp; Equipment

Description	Part number
Tool	T71 601 120

fig 3-27



fig 3-28

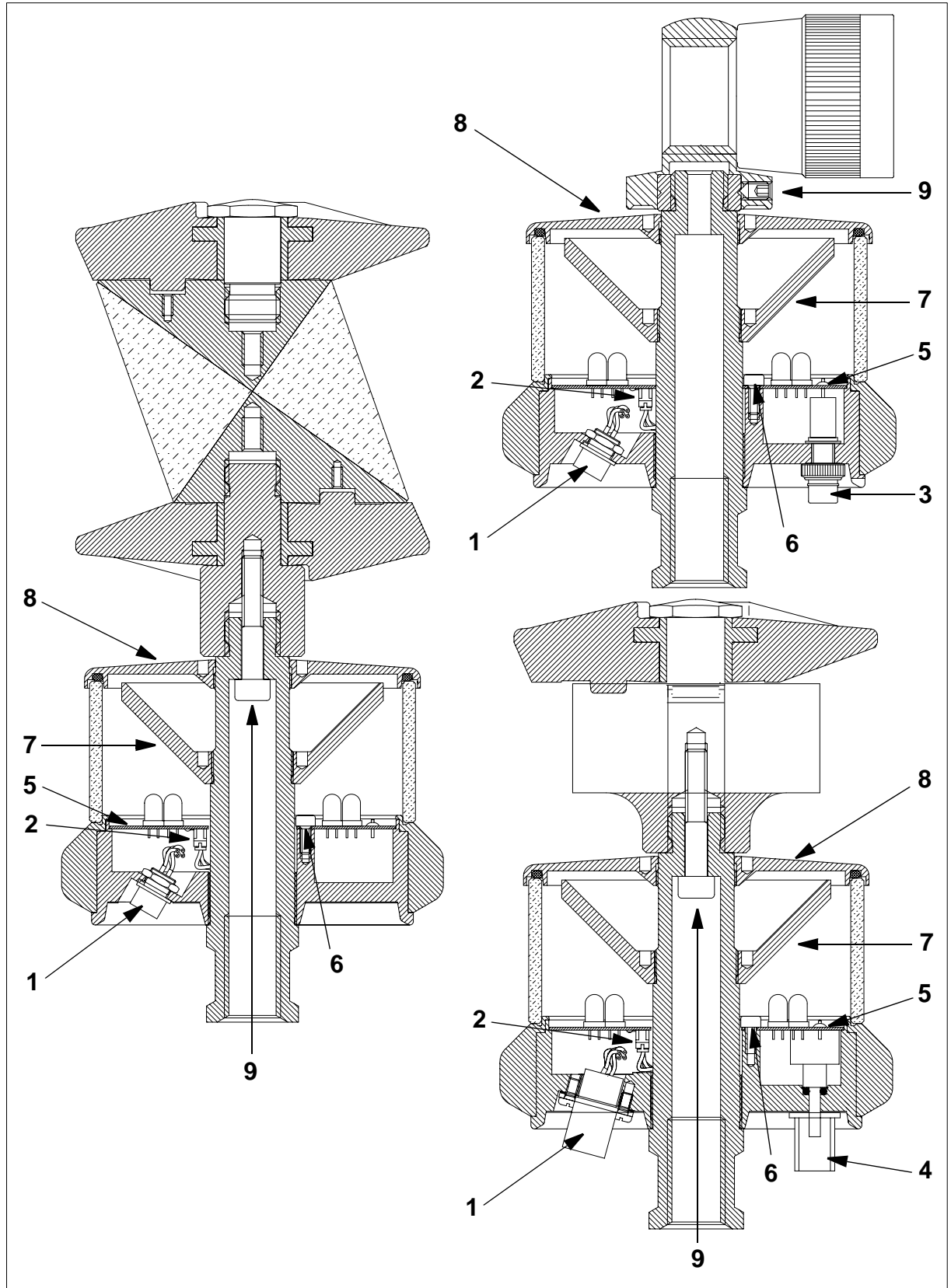

## Performance

Item	Action	Performance	Result	Notes
1	Fit the connector.	<i>Cannon:</i> The connector are held by four screws. <i>Hirose:</i> Mount the locking ring from inside the RMT.		
2	Mount the cable from the connector to the RFC / RFCM board.			
3	Fit the switches to the RFC / RFCM board.			Only for RMT Super.
4	Fit the channel switch knob.			Only multi channel RMT
5	Fit the RFC / RFCM board.	Connect the cable from the connector and place the board into position.		See electrical description for correct configuration of the RFCM board.
6	Fix the RFC / RFCM board.	Secure the board with three screws and glue at four points with pliabond.		Use Loctite 242 or 243 on the threads of the screws.
7	Fit the mirror.	Use the tool T71 601 120.		Use Loctite 242 or 243 to lock the mirror.
8	Fit the lid.	Use the tool T71 601 120, <i>See fig 3-25.</i>		Seal and lock the lid with Pliabond.
9	Fit the prism.	Secure the prism with one screw. Use an allen key.		Lock the screw with Loctite.

## Prism ring - 571 233 023

### Removal

#### Tools & Equipment

Description	Part number
RMT spanner tool	T71 601 542
Spanner, 19 mm	

fig 3-29

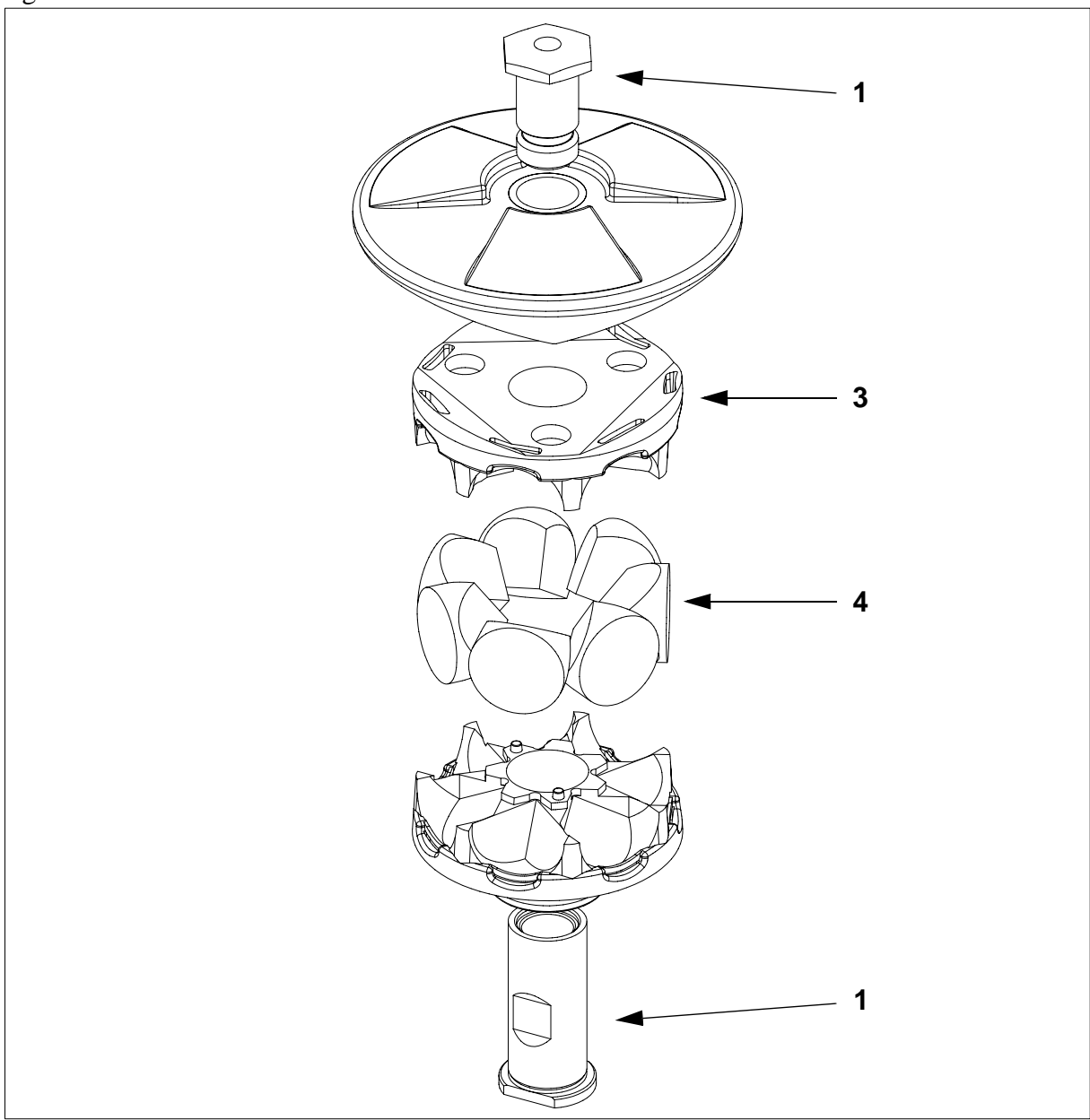



## Performance

Item	Action	Performance	Result	Notes
1	Remove the screw.	Use the RMT spanner tool and a 19 mm spanner.		
2	Remove the prism assembly.			
3	Remove the upper prism holder.			
4	Remove the prisms			

Assembling

Tools & Equipment

Description	Part number
RMT spanner tool	T71 601 542
Spanner, 19 mm	

fig 3-30

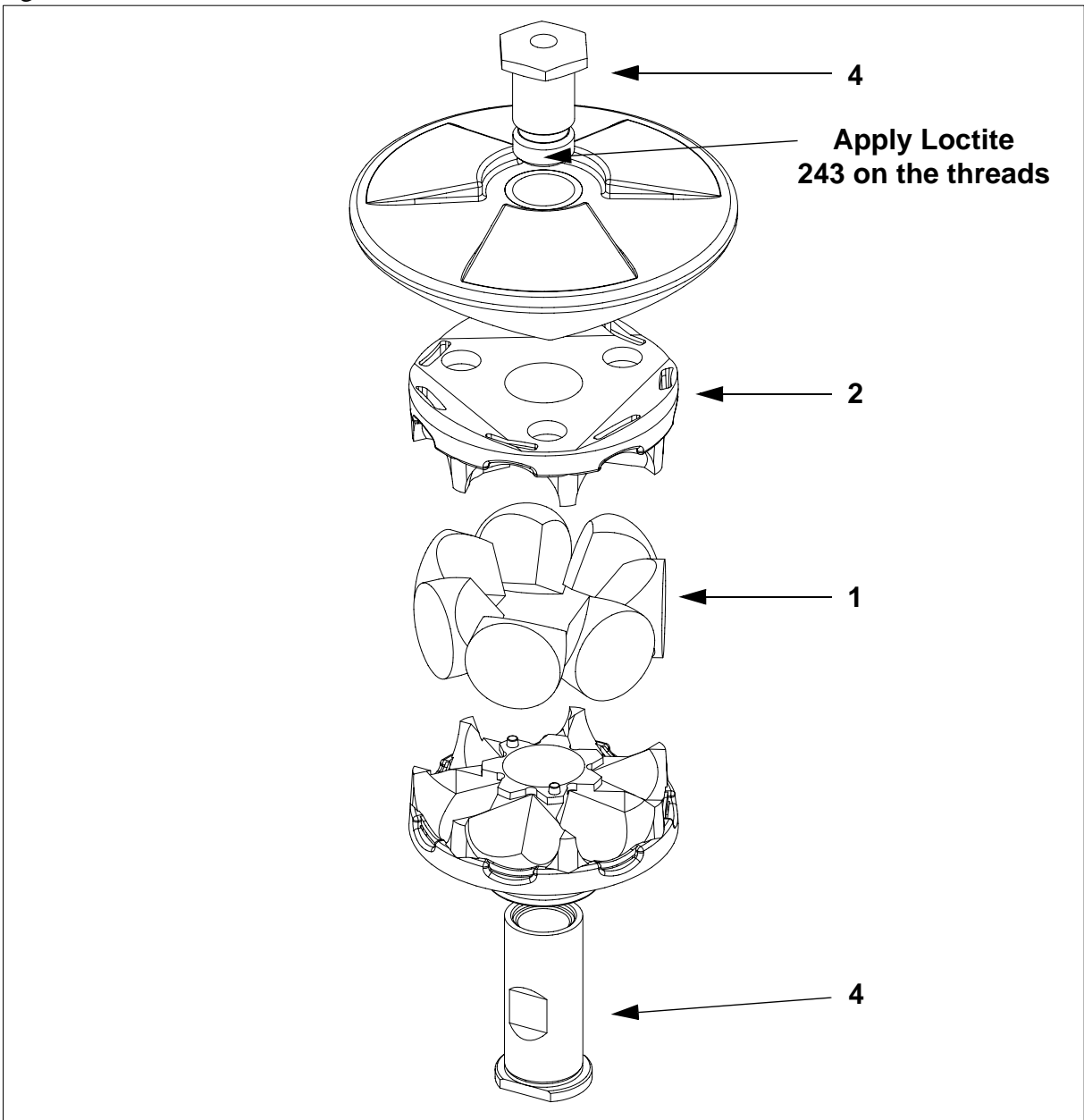

## Performance

Item	Action	Performance	Result	Notes
1	Fit the prisms to the lower prism holder.			
2	Fit the upper prism holder to the lower.			If one of the prism holders must be changed, change both.
3	Fit the prism assembly to the spacer.			
4	Fit the screw.	Use the RMT spanner tool and a 19 mm spanner.		If the prism holders have been changed, change the screw to the new type. Apply Loctite 243 on the threads of the screw.

# RMT 600 TS - 571 204 240

## Removal

### Tools & Equipment

Description	Part number
-------------	-------------

3 mm ball allen key

fig 3-31

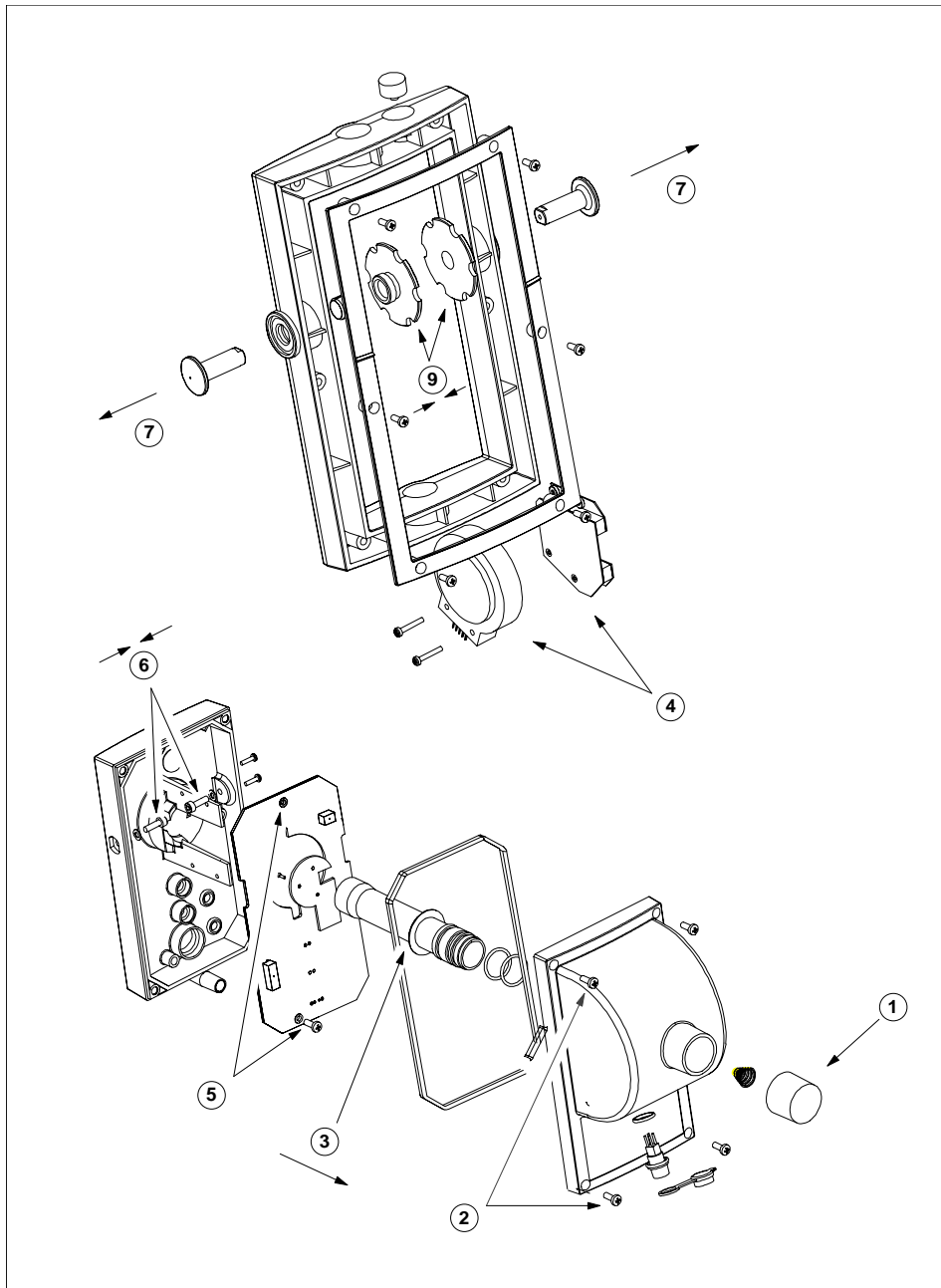

## Performance

Item	Action	Performance	Result	Notes
1	Remove the Battery cap.			
2	Remove the Back cover.	Remove the four screws.		
3	Remove the battery holder with the BBR board.	Disconnect the four lead cable from the FRT board.		
4	Remove the angle unit.	Remove the four screws holding the bracket attached to the angle unit. Also remove the ten lead cable from the FRT board.		The angle unit is mounted the bracket with double sided tape.
5	Remove the FRT board.	Remove the three screws holding the board including the GND cable for the Hirose connector.		
6	Remove the locking screws.	Remove the two screws holding the yoke.		Use a 3 mm ball allen key.
7	Remove the axis.			
8	Remove the Yoke.			

Assembling

Tools & Equipment

Description	Part number
High vacuum grease	R71 905 946
Loctite 270 & Isoflex 3000	
3 mm ball allen key	

fig 3-32

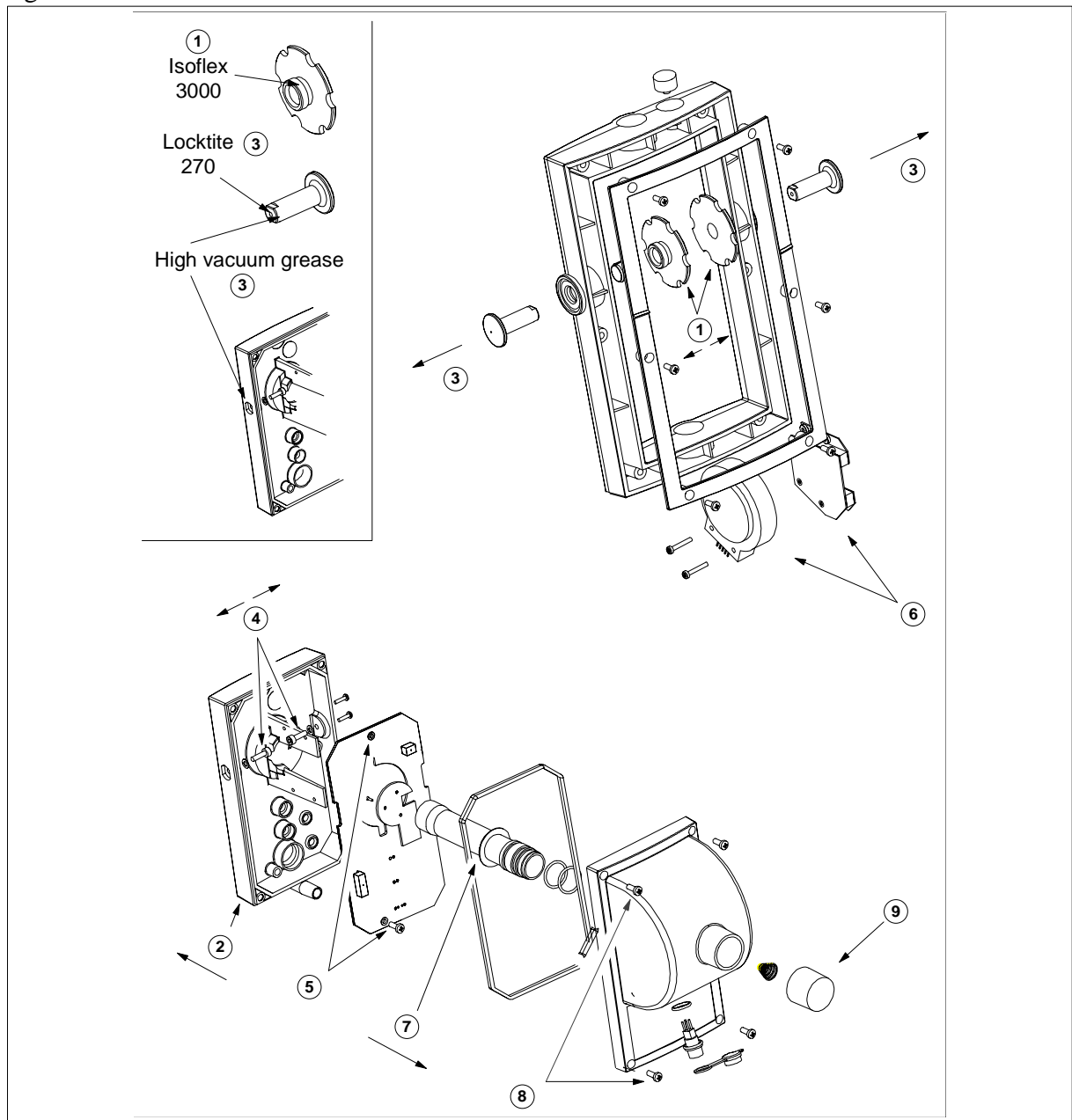

## Performance

Item	Action	Performance	Result	Notes
1	Mount the locking ring and locking screw.	Place a thin layer of Isoflex 3000 on the threads of the screw.		
2	Place the yoke in the frame			Make sure the front of the yoke and the frame are facing the same direction.
3	Grease and mount the axis.	Apply high vacuum grease on the edge of the axis and on the side of the Yoke. <b>NOTE:</b> make sure grease will not enter the threads of the axis. Also apply Loctite 270 in the threads of the axis.		
4	Mount the locking screws.	Make sure they are tightened properly.		
5	Mount the FRT board.	Mount the GND cable on the screw hole near the axis.		
6	Mount the angle unit.	The unit is attached with four screws.		If the angle unit is replaced or removed from the bracket, mount the unit with double sided tape to the bracket.
7	Place the battery holder with BBR board in position.	Make sure the guiding pin at the bottom is in its place and the two guiding plates fit in the slots of the holder.		

## Performance

Item	Action	Performance	Result	Notes
8	Mount the sealing.	Place the sealing with the thick side in the back cover.		
9	mount the back cover.	Mount the four screws.		
10	Mount the end cap of the battery holder.			



# Holders

## ACU Holder - 571 224 091

### Removal

#### Tools & Equipment

Description	Part number
Torx screw driver T6	
Torx screw driver T10	
Torx screw driver T20	
Allen key, 4 mm	

#### Performance

Item	Action	Performance	Result	Notes
1	Remove back cover	1. Place holder up side down. 2.Remove the back cover.		1. Use a Torx T10 screw driver.

fig 3-33

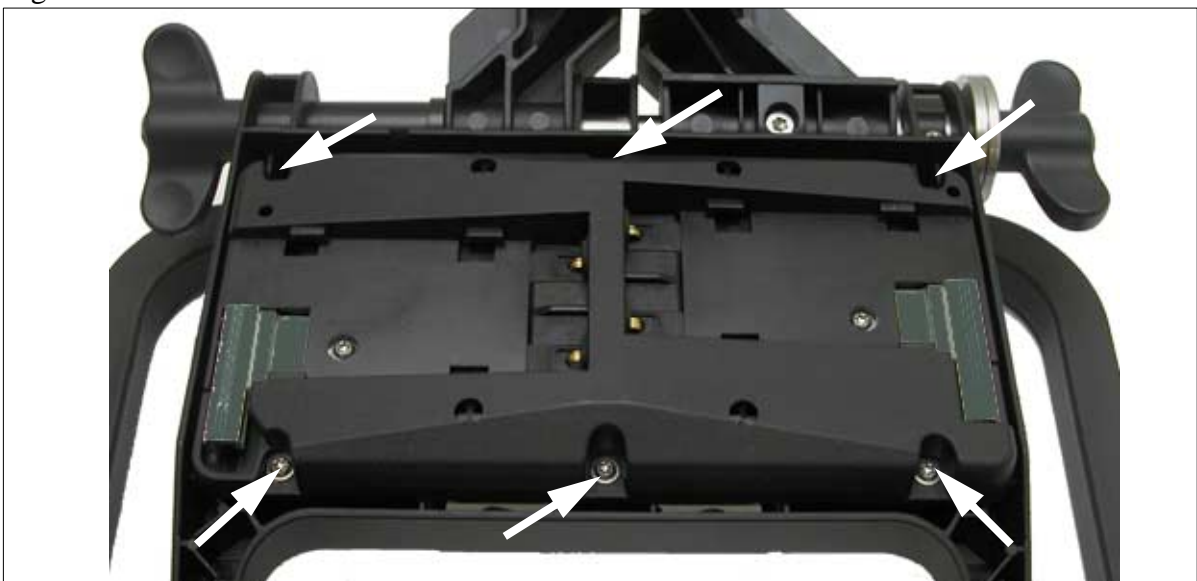

Performance

Item	Action	Performance	Result	Notes
2	Remove board.	Remove the CAP2 board		Use a Torx T6 screw driver.

fig 3-34

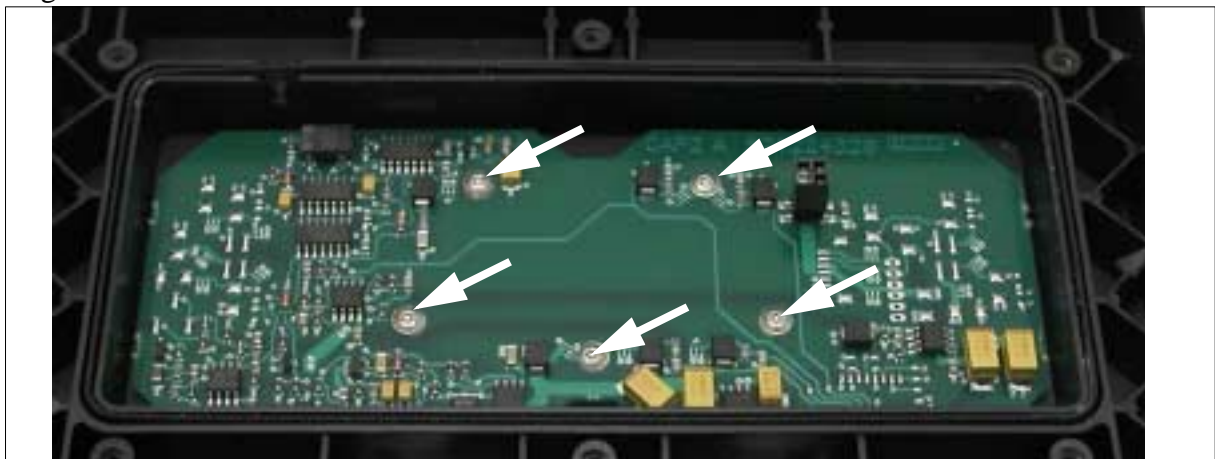

3	Remove board.	Remove the BCB2 board.		Use a Torx T6 screw driver.
---	---------------	------------------------	--	-----------------------------

fig 3-35



Performance

Item	Action	Performance	Result	Notes
------	--------	-------------	--------	-------

4	Remove sealing.	Remove sealing.		
---	-----------------	-----------------	--	--

fig 3-36

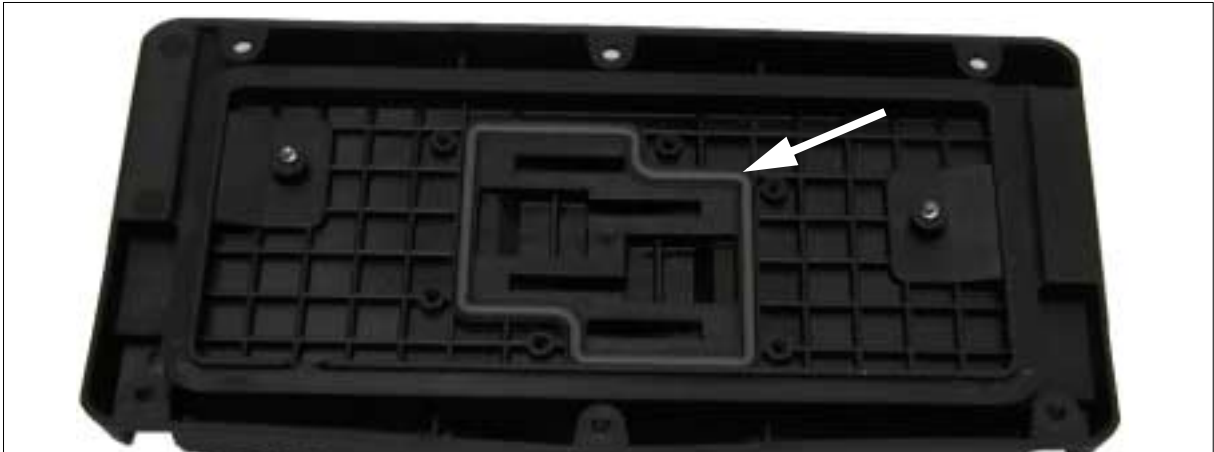

5	Remove batteryholders.	Remove the battery holders		2. Use a Torx T10 screw driver.
---	------------------------	----------------------------	--	---------------------------------

fig 3-37

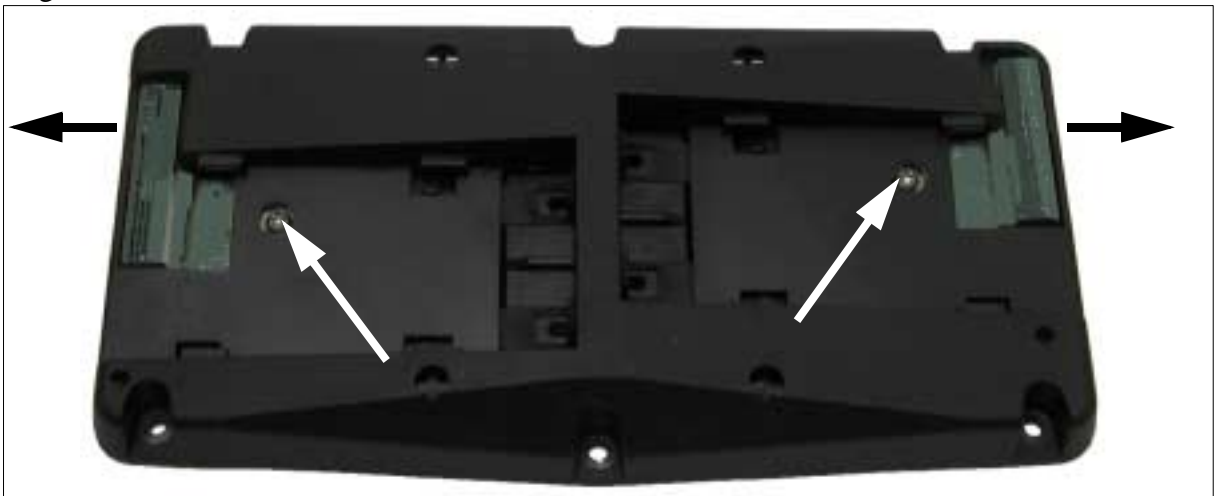

Performance

Item	Action	Performance	Result	Notes
6	Remove sealing.	Remove the battery contact sealing		

fig 3-38



7	Remove sealing.	<ol style="list-style-type: none"> <li>1. Remove the back cover sealing.</li> <li>2. Remove the plug.</li> <li>3. Remove the spring contact sealing.</li> </ol>		
---	-----------------	---	--	--

fig 3-39

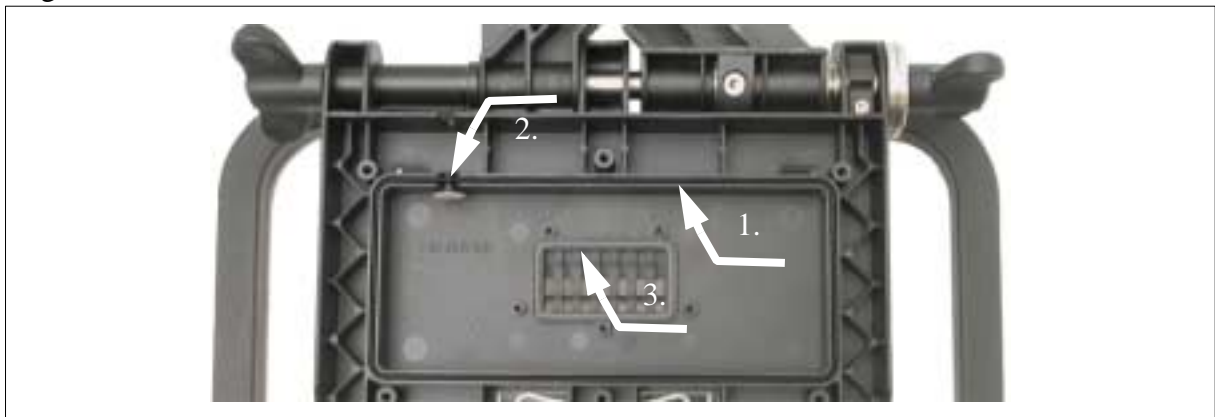

Performance

Item	Action	Performance	Result	Notes
8	Remove axle.	1. Remove the knob CCW. 2. Remove the support lock for axle. 3. Loosen the lock for axle. 4. Remove the locking washer. 5. Pull out the axle.		2. Use Torx T20 screw driver. 3. Use Torx T10 screw driver.

fig 3-40

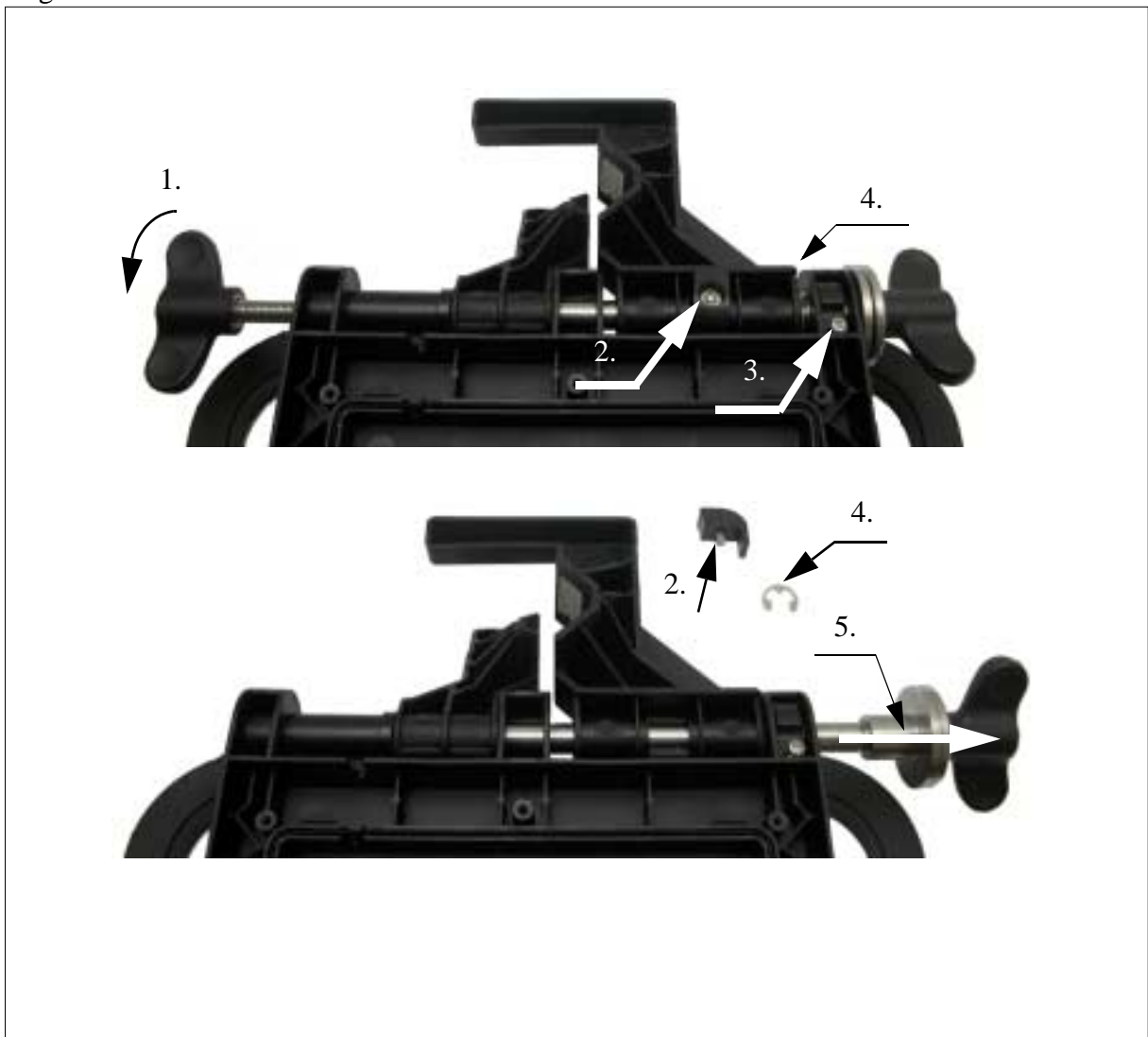

Performance

Item	Action	Performance	Result	Notes
9	Remove the pole lock.	1. Remove the pole lock. 2. Remove the locking tube 3. Remove the lock for axle. 4. Remove the knob. 5. Remove the locking pin and washer. 6. Remove the locking sleeve.		4. Use a 4 mm allen key.

fig 3-41

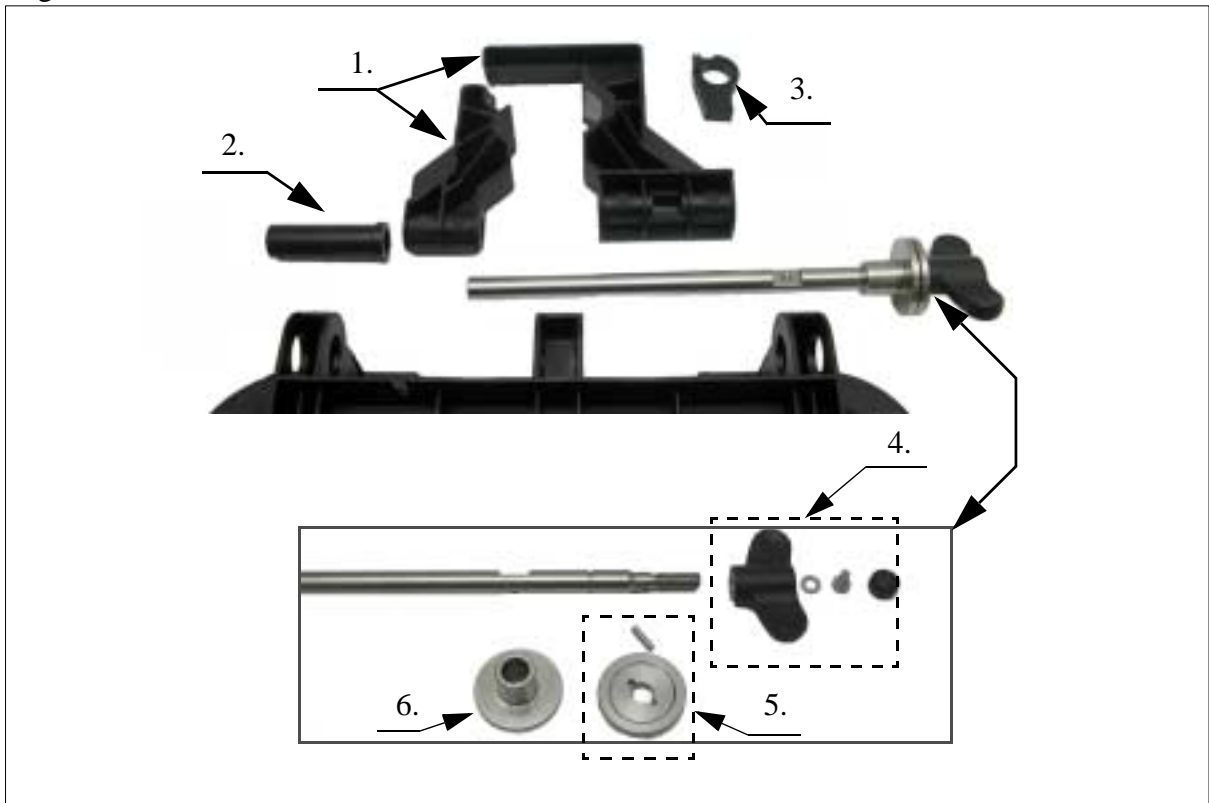

10	Remove the handle.	Remove the four screws and handle.		Use a 4 mm allen key.
----	--------------------	------------------------------------	--	-----------------------

### Performance

Item	Action	Performance	Result	Notes
------	--------	-------------	--------	-------

fig 3-42

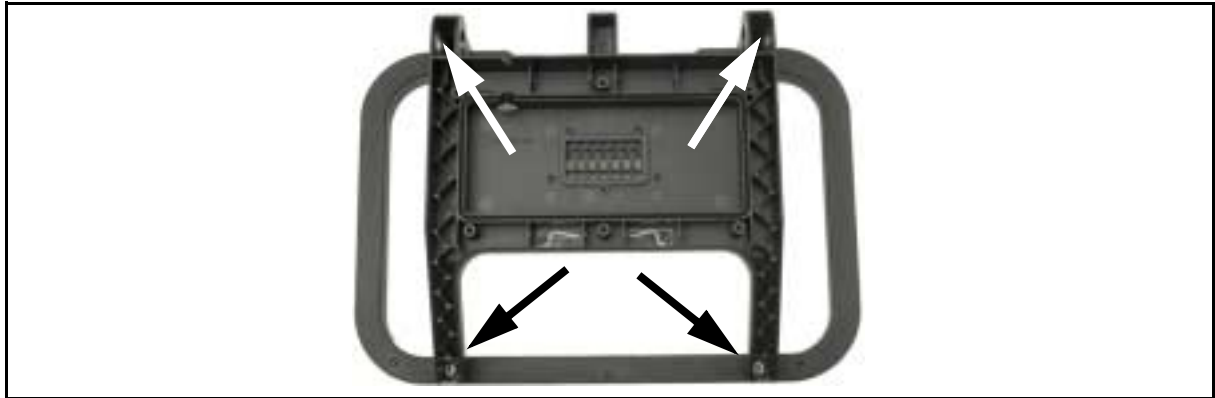

## Assembling

### Tools & Equipment

Description	Part number
Torx screw driver T6	
Torx screw driver T10	
Torx screw driver T20	
Allen key, 4 mm	

### Performance

Item	Action	Performance	Result	Notes
1	Mount the handle.	1. Mount the handle. 2. Tighten the four screws.		2. Use a 4 mm allen key.

fig 3-43

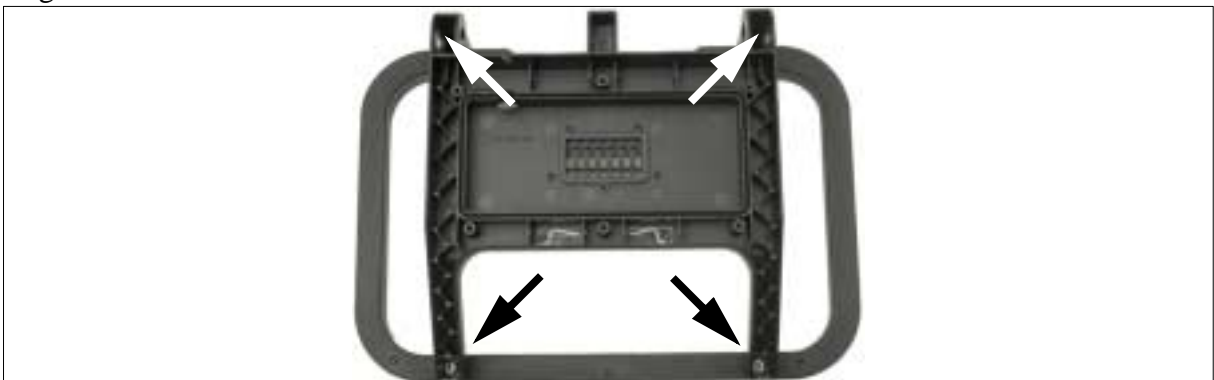



Performance

Item	Action	Performance	Result	Notes
2	Mount axle and pole lock.	1. Mount the locking sleeve, the locking pin with washer and the knob. 2. Mount locking tube. 3. Place the lock for axle in position. 4. Mount axle and pole lock on to the holder. 5. Mount locking washer. 6. Mount support lock for axle and tighten the screw. 7. Tighten the lock for axle screw. 8. Mount knob CW.		1. Use a 4 mm allen key. 6. Use Torx T20 screw driver. 7. Use Torx T10 screw driver.

fig 3-44

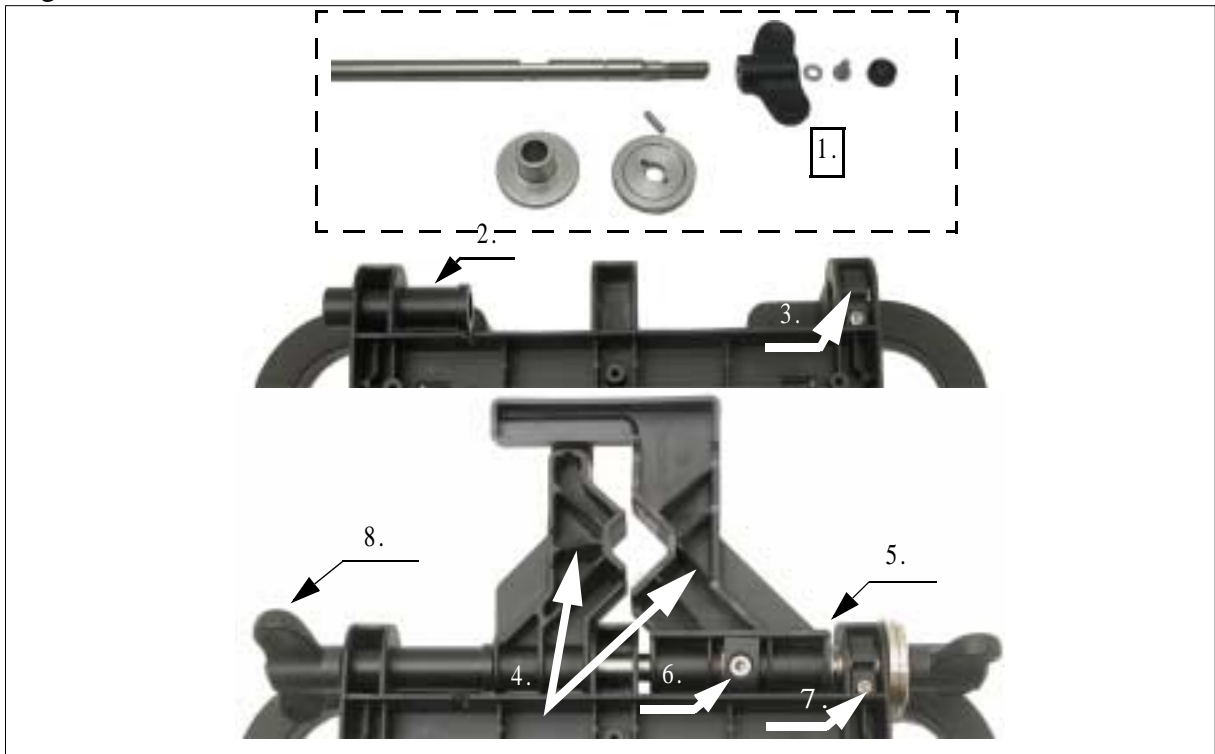

Performance

Item	Action	Performance	Result	Notes
3	Mount sealings	1. Mount the back cover sealing. 2. Mount the plug. 3. Mount the spring contact sealing.		

fig 3-45

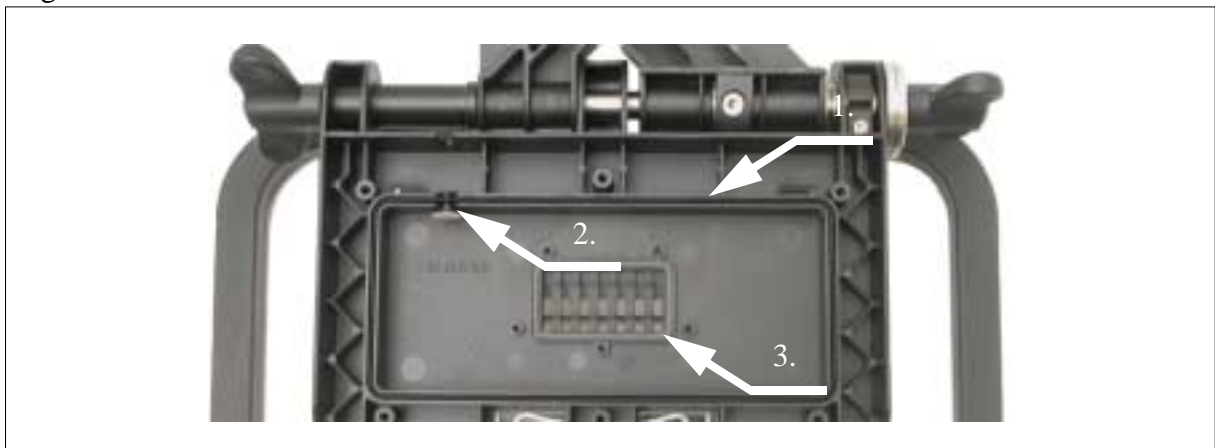

4	Mount board.	Mount the CAP2 board.		Use a Torx T6 screw driver.
---	--------------	-----------------------	--	-----------------------------

fig 3-46



5	Mount sealing and battery holders.	1. Mount battery sealing 2. Mount battery holders		2Use a Torx T10 screw driver.
---	------------------------------------	--	--	-------------------------------

Performance

Item	Action	Performance	Result	Notes
------	--------	-------------	--------	-------

fig 3-47

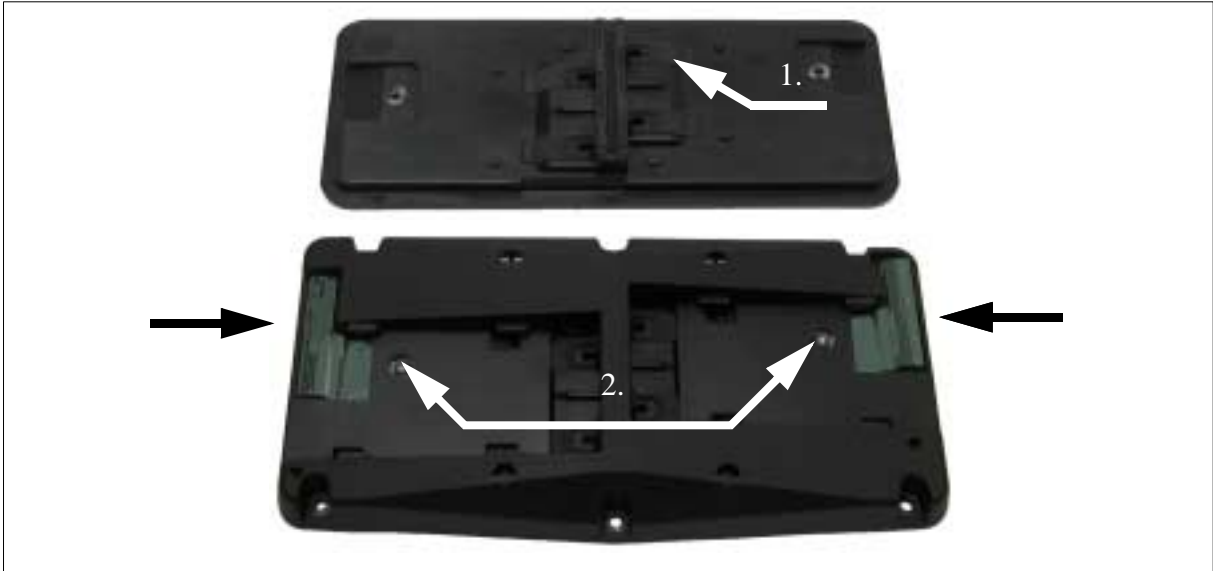

6 Battery sealing and board.

1. Mount sealing.  
2. Mount BCB2 board.

2. Use Torx T6 screw driver.

fig 3-48



7 Mount Back cover.

1. Mount Back cover.

Use Torx T10 screw driver.

### Performance

Item	Action	Performance	Result	Notes
------	--------	-------------	--------	-------

fig 3-49



## CU Holder - 571 224 061

### Removal

### Tools & Equipment

Description	Part number
Torx screw driver T6	
Torx screw driver T10	
Torx screw driver T20	
Allen key, 4 mm	

### Performance

Item	Action	Performance	Result	Notes
1	Remove back cover CAP board.	1. Remove back cover. 2. Remove CAP board.		1. Use a Torx T10 screw driver. 2. Use a Torx T6 screw driver.

### Performance

Item	Action	Performance	Result	Notes
------	--------	-------------	--------	-------

fig 3-50

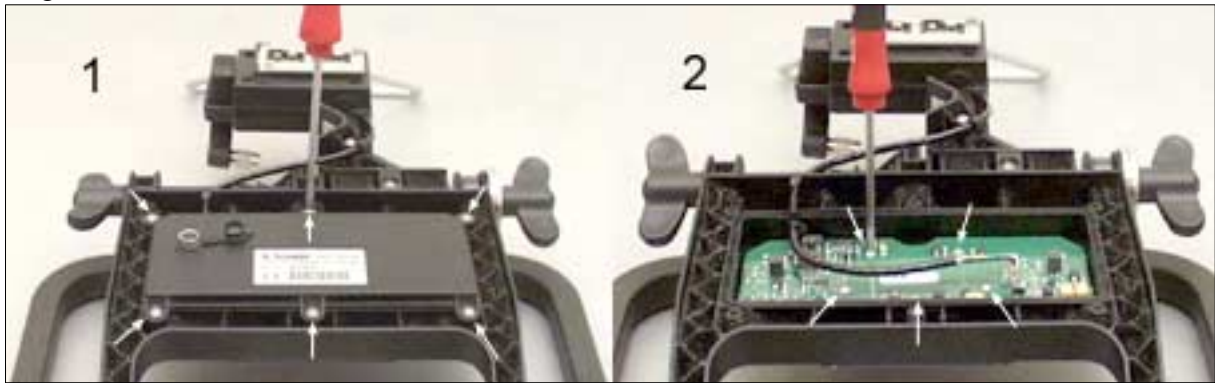

### Performance

Item	Action	Performance	Result	Notes
2	Remove sealing.	1. Remove sealing for contact springs. 2. Remove back cover sealing.		

fig 3-51

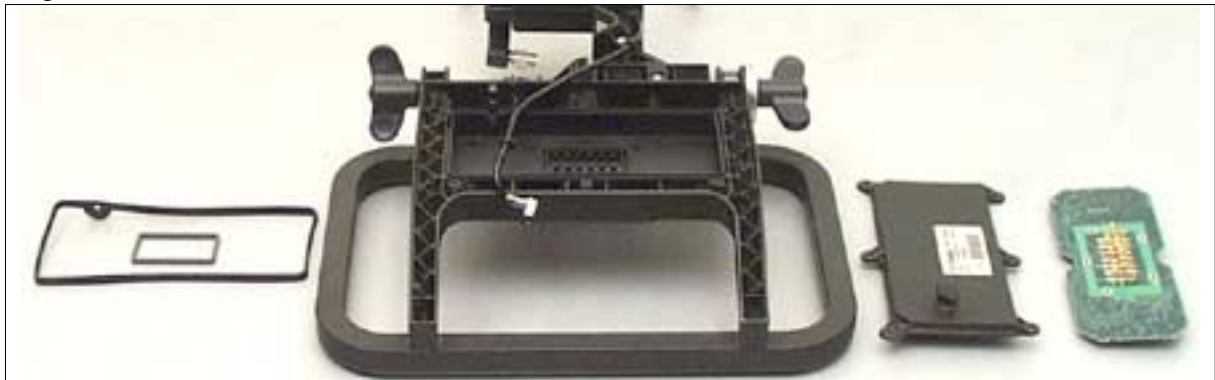

3	Remove battery plate and cover for TBD board.	1. Remove plate. 2. Remove cover.		Use a Torx T10 screw driver.
---	---	--------------------------------------	--	------------------------------

fig 3-52

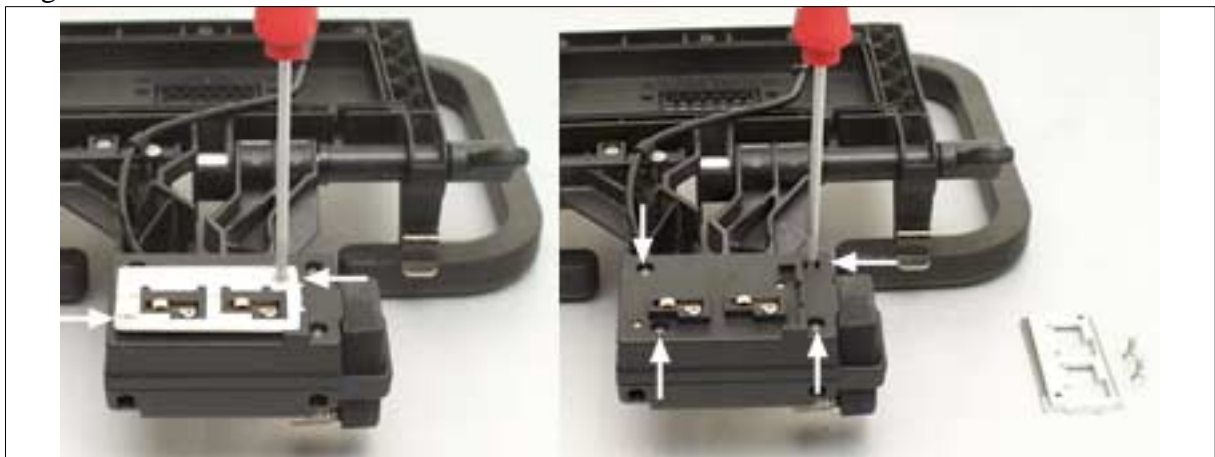

Performance

Item	Action	Performance	Result	Notes
4	Remove radio connector.	1. Remove cable from CAP board. 2. Remove radio connector. 3. Remove sealing.		

fig 3-53

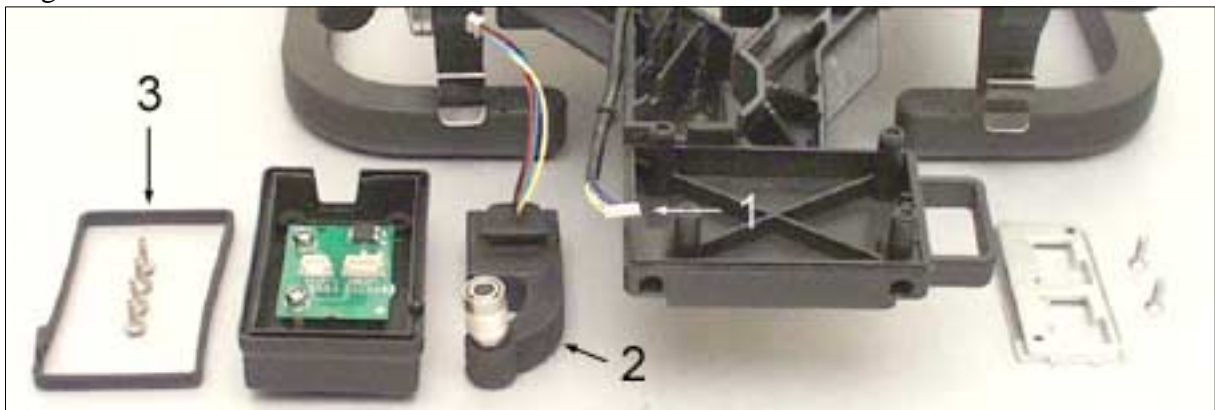

5	Remove TBD board.	1. Remove two nuts, TBD board. 2. Remove two battery connecting pins.		
---	-------------------	--	--	--

fig 3-54



Performance

Item	Action	Performance	Result	Notes
6	Remove right side knob.	1. Place holder up side down. 2. Remove knob CCW.		

fig 3-55



7	Remove left side knob.	1. Remove end cap. 2. Remove locking screw. 3. Remove left side knob CCW. 4. Remove locking washer. 5. Remove locking pin.		2. Use a 4 mm allen key.
---	------------------------	--	--	--------------------------

fig 3-56





### Performance

Item	Action	Performance	Result	Notes
8	Remove axle.	<ol style="list-style-type: none"> <li>1. Remove support lock for axle.</li> <li>2. Loosen lock for axle.</li> <li>3. Remove locking washer.</li> <li>4. Remove locking sleeve.</li> <li>5. Pull out the axle.</li> <li>6. Remove locking tube, radio holder and pole lock.</li> </ol>		<ol style="list-style-type: none"> <li>1. Use Torx T20 screw driver.</li> <li>2. Use Torx T10 screw driver.</li> </ol>

fig 3-57

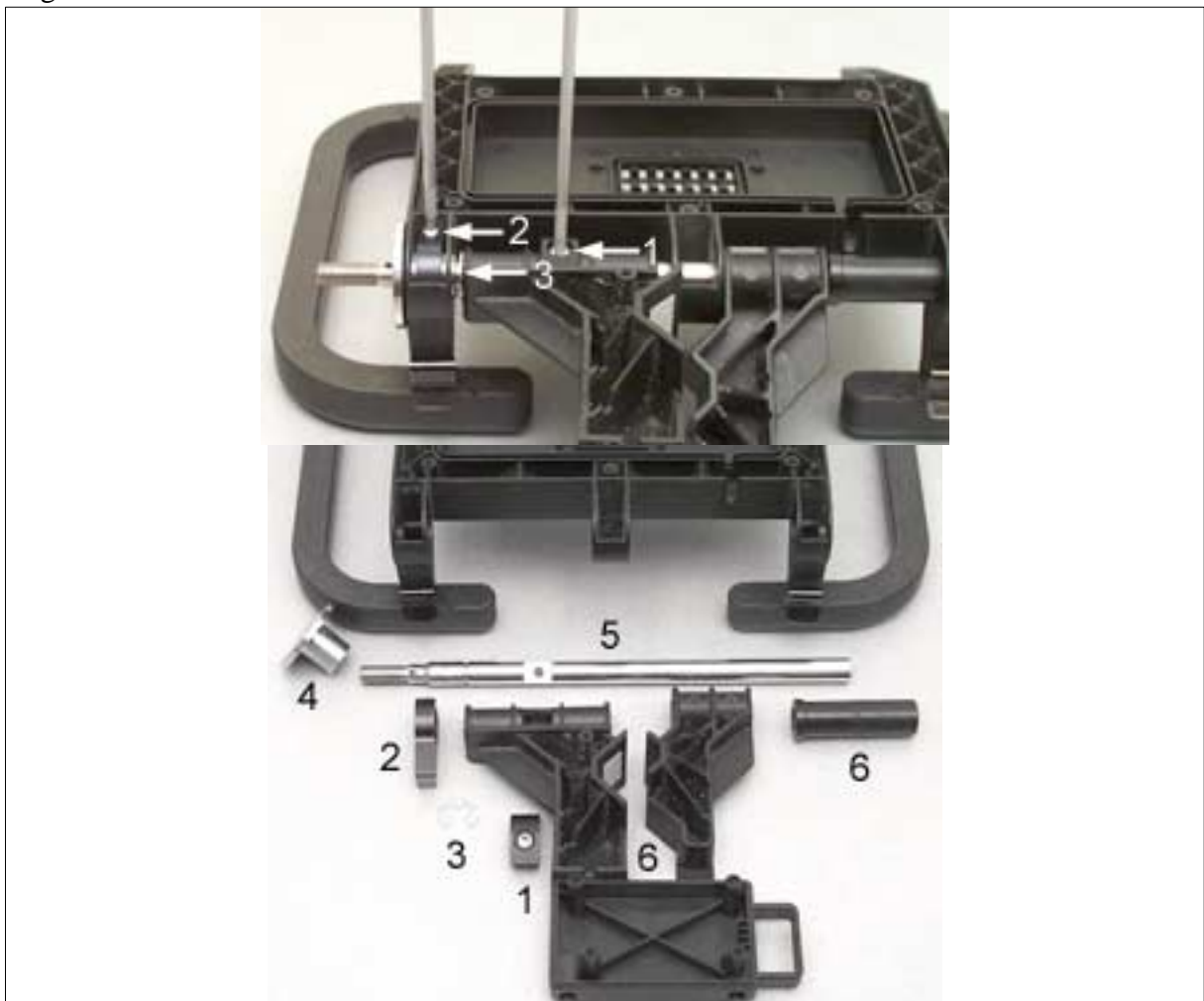

## Performance

Item	Action	Performance	Result	Notes
9	Remove the handle.	Remove four screws, two pen holders and handle.		Use a 4 mm allen key.

fig 3-58

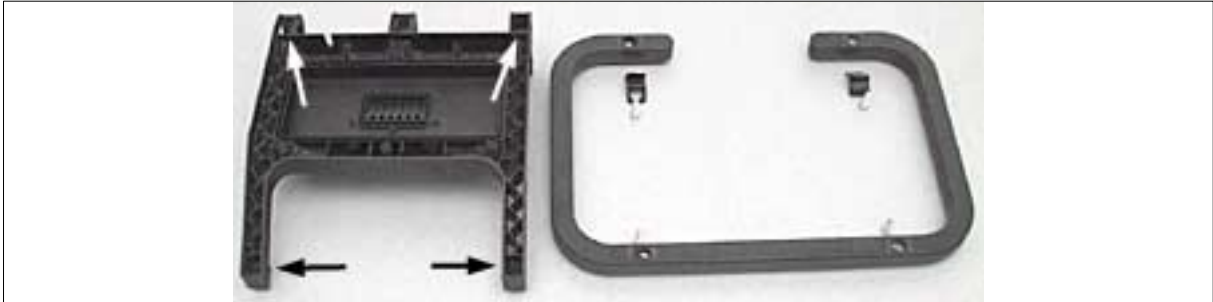

## Assembling

### Tools & Equipment

Description	Part number
Torx screw driver T6	
Torx screw driver T10	
Torx screw driver T20	
Allen key, 4 mm	

### Performance

Item	Action	Performance	Result	Notes
1	Mount the handle.	<ol style="list-style-type: none"> <li>1. Mount the two pen holders.</li> <li>2. Mount the handle.</li> <li>3. Tighten the four screws.</li> </ol>		3. Use a 4 mm allen key.

fig 3-59



Performance

Item	Action	Performance	Result	Notes
2	Mount axle.	<ol style="list-style-type: none"> <li>1. Place the lock for axle in position.</li> <li>2. Mount locking tube.</li> <li>3. Mount axle with locking sleeve, radio holder and pole lock.</li> <li>4. Mount locking washer.</li> <li>5. Mount support lock for axle and tighten the screw.</li> <li>6. Tighten the lock for axle screw.</li> </ol>		<ol style="list-style-type: none"> <li>5. Use Torx T20 screw driver.</li> <li>6. Use Torx T10 screw driver.</li> </ol>

fig 3-60



Performance

Item	Action	Performance	Result	Notes
3	Mount left side knob.	<ol style="list-style-type: none"> <li>1. Mount locking pin and washer.</li> <li>2. Mount knob CW.</li> <li>3. Mount washer and screw.</li> <li>4. Mount end cap.</li> </ol>		3. Use a 4 mm allen key.

fig 3-61

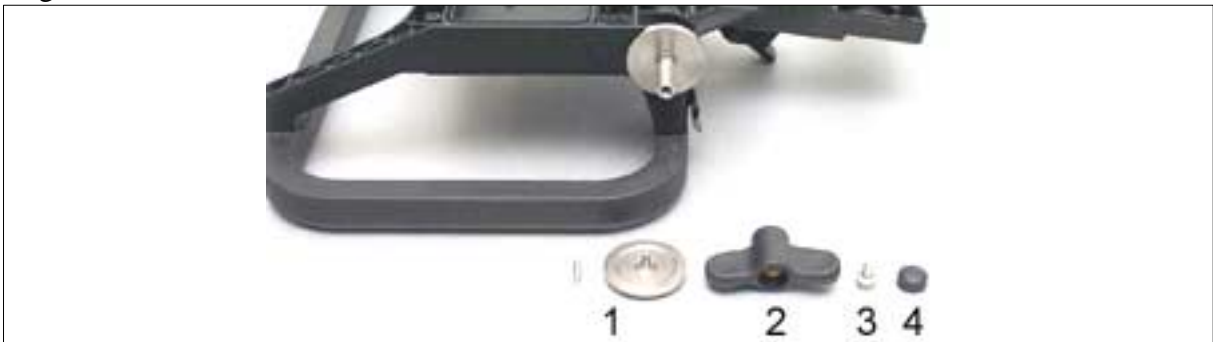

4	Mount right knob.	Mount the knob CW.		
---	-------------------	--------------------	--	--

fig 3-62



5	Mount TBD board.	<ol style="list-style-type: none"> <li>1. Mount TBD board and tighten the nuts.</li> <li>2. Mount battery connecting pins.</li> </ol>		
---	------------------	---	--	--

fig 3-63

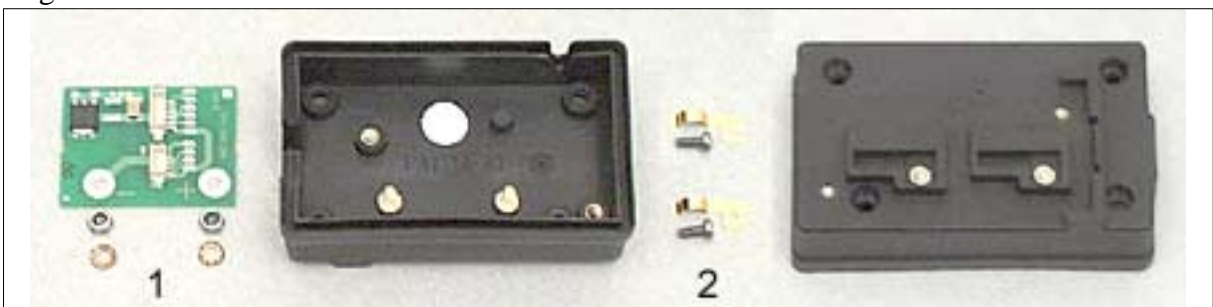

Performance

Item	Action	Performance	Result	Notes
6	Battery holder assembly.	1. Mount radio connector. 2. Mount cable to CAP board. 3. Mount sealing. 4. Mount battery holder.		Use Torx T10 screw driver.

fig 3-64

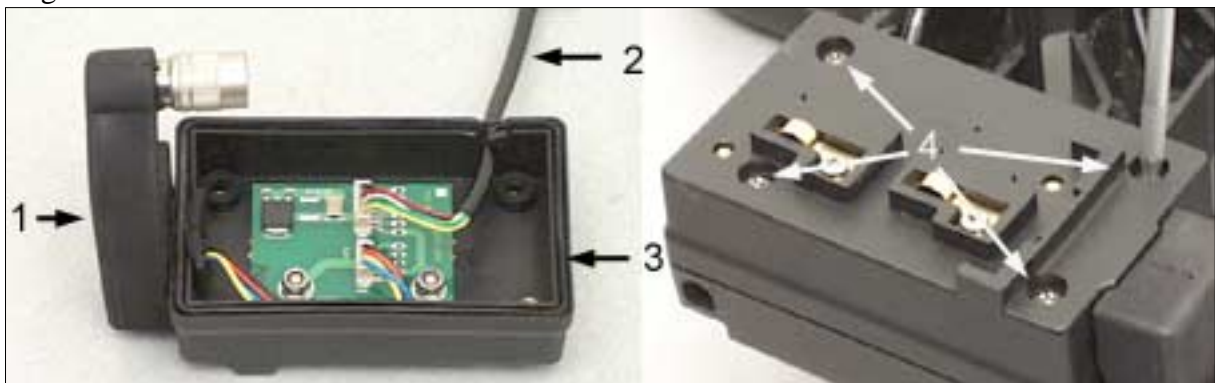

7	Mount battery plate, cable and support.	1. Mount battery plate. 2. Mount cable to CAP board. 3. Mount support.		Use Torx T10 screw driver.
---	---	--	--	----------------------------

fig 3-65

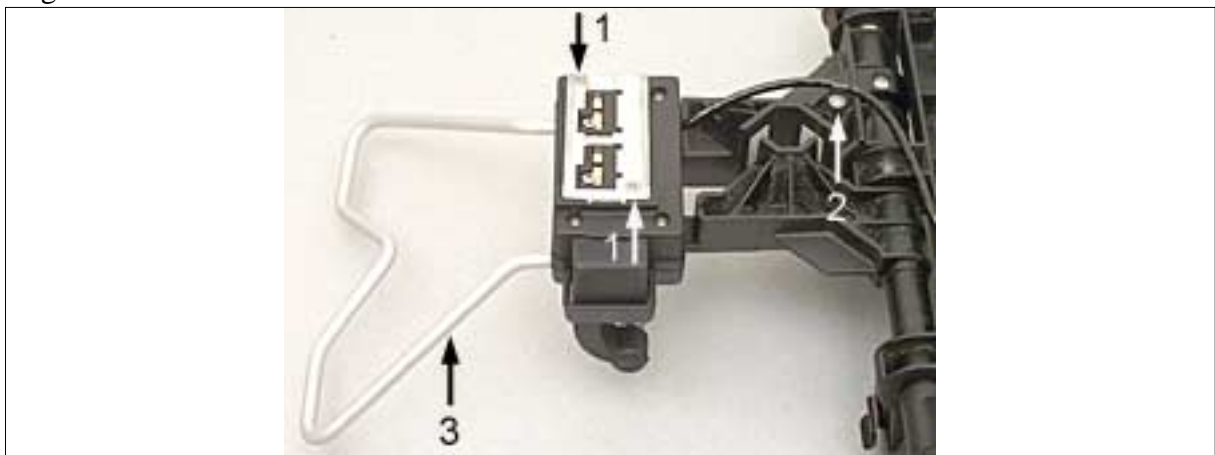

Performance

Item	Action	Performance	Result	Notes
8	Mount sealing.	1. Mount back cover sealing. 2. Mount spring contact sealing.		

fig 3-66



9	Mount CAP board and back cover.	1. Mount CAP board. 2. Mount back cover.		1. Use Torx T6 screw driver. 2. Use Torx T10 screw driver.
---	---------------------------------	---	--	---

fig 3-67

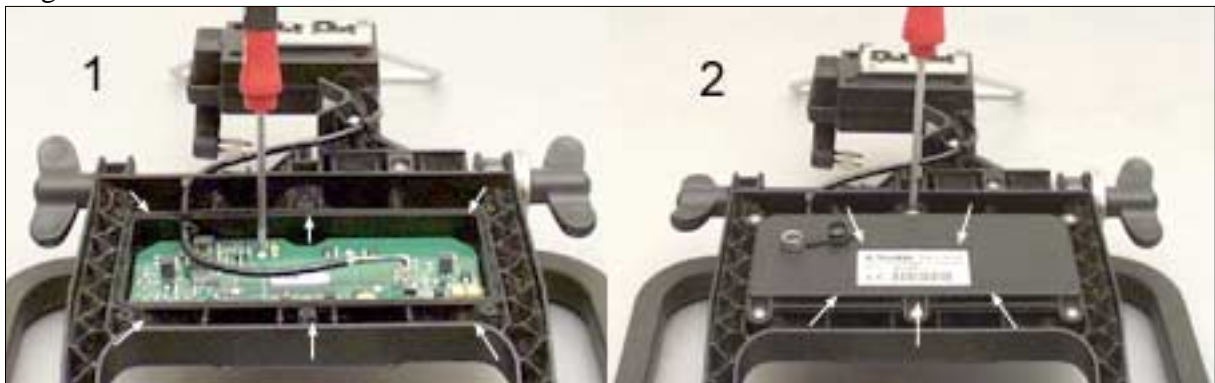

# Tribrach

Tribrach - 571 905 560/2

## Removal

fig 3-68

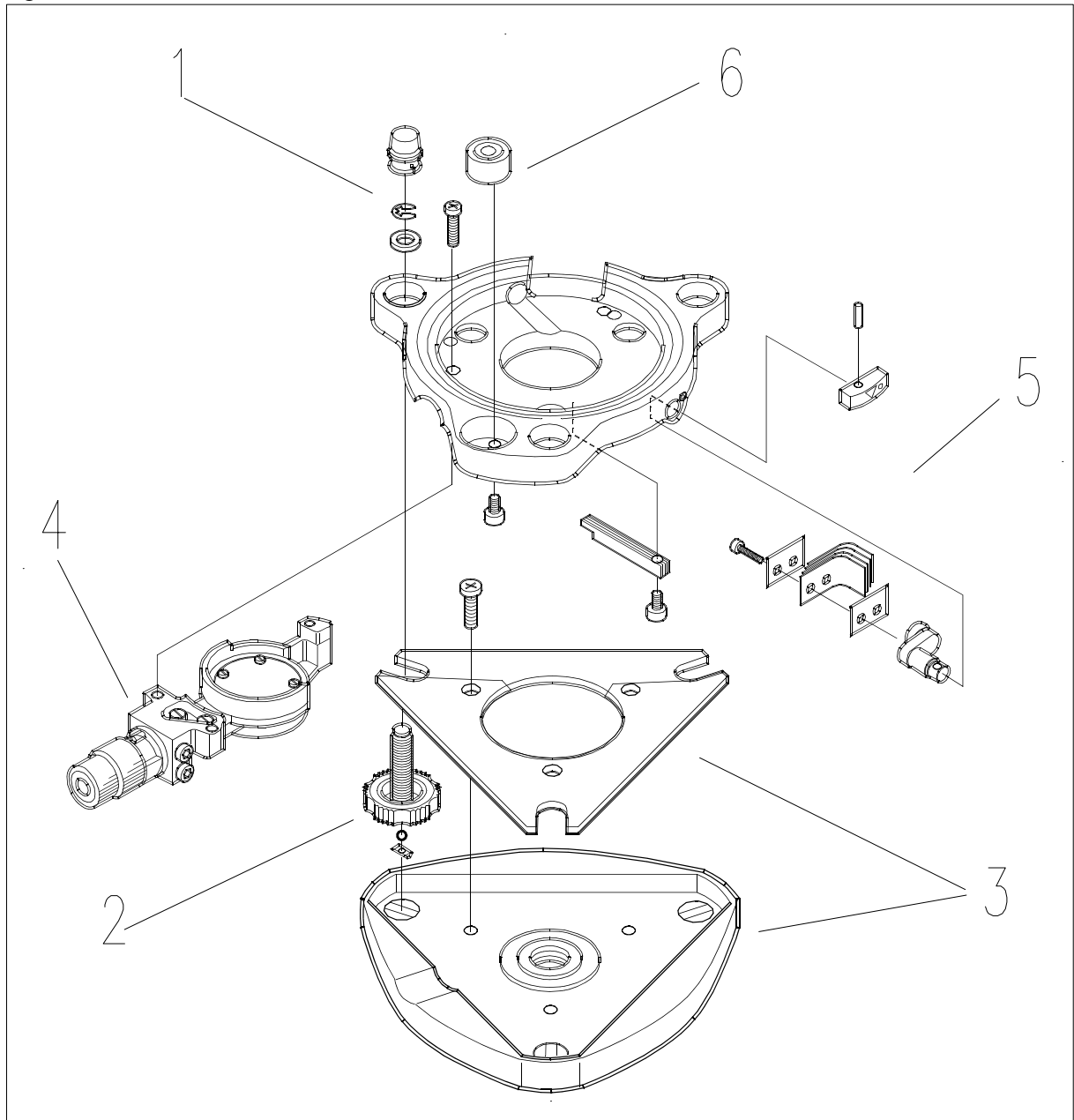



## Performance

Item	Action	Performance	Result	Notes
1	Remove the cap and the clip.			
2	Remove the three footscrews.	Unscrew the three footscrews.		
3	Remove the support- and base plate.			
4	Remove the optical plumb.	Remove the three screws holding the optical plumb.		
5	Remove the spring assembly.	Remove the two screws holding the spring assembly.		
6	Remove the level.	Remove the three screws holding the level.		

Assembling

fig 3-69

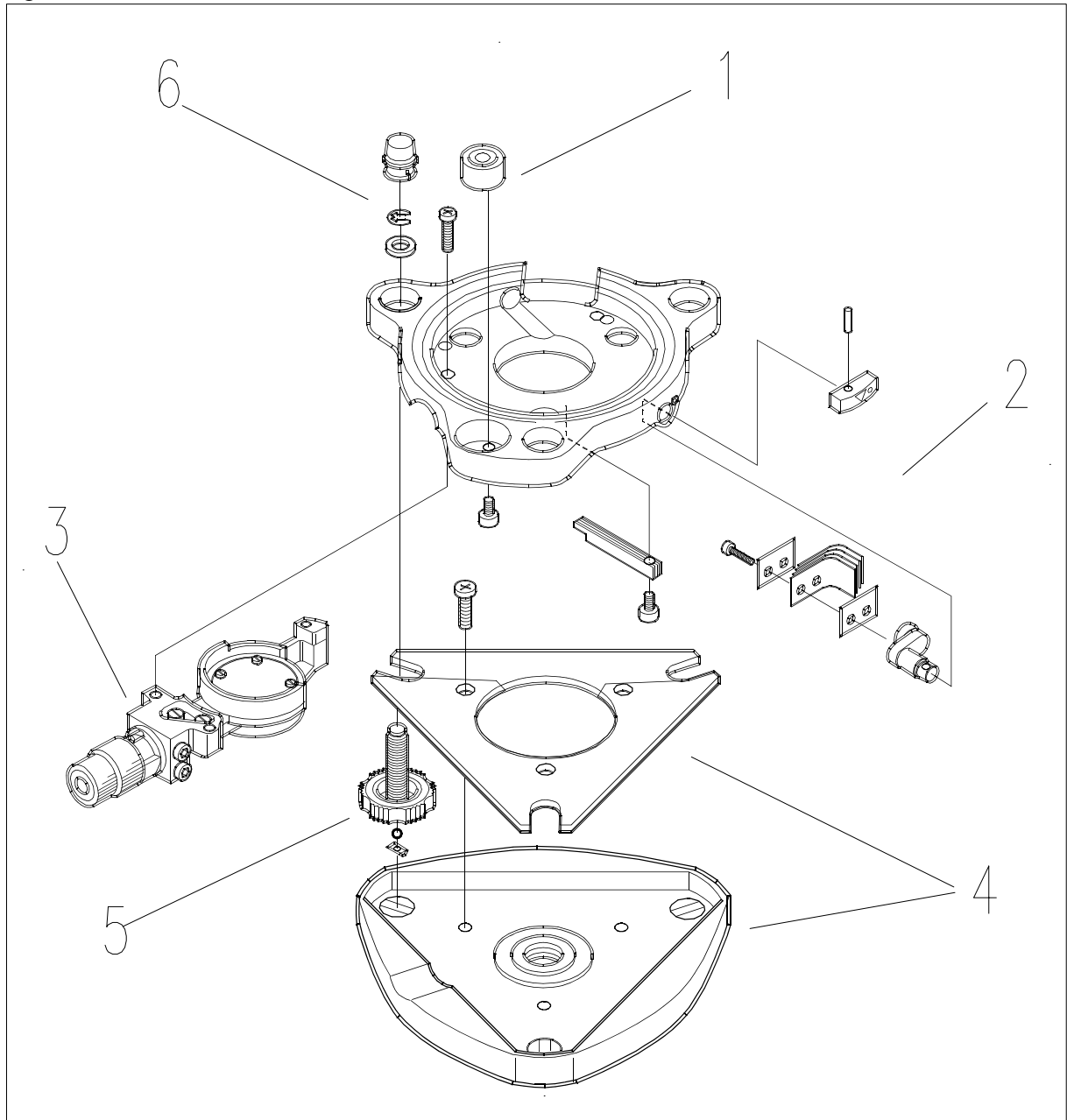

## Performance

Item	Action	Performance	Result	Notes
1	Mount the level.	Mount the three screws.		
2	Mount the spring assembly.	Place two plates on each side of the four springs and mount them with the two screws.		
3	Mount the optical plumb.	Mount the three screws.		
4	Mount the foot-screws and support plate.	Place the support plate in place between the three footscrews.		
5	Mount the base plate.	Mount the three screws.		
6	Mount the clip and fit the cap.			

Adjustment setup

Tools & Equipment

Description	Part number
Level & optical plumb adjustment tool, <i>fig 3-70</i>	T08 143 203
Marker	571 908 960
Fixed tribrach	

fig 3-70



Performance

Item	Action	Performance	Result	Notes
1	Place the tool in a fixed tribrach.	Use the compensator calibration tribrach or a tribrach on a measuring pillar.		If the compensator calibration tribrach is used make sure the arm is always in the same position.

fig 3-71



Performance

Item	Action	Performance	Result	Notes
2	Place a tribrach on the tool.			The optical plumb on the tribrach must be well adjusted.

fig 3-72



3	Make a mark in the ceiling.	Turn the tribrach 180 deg to make sure the mark is centred.		
4	Mount a mark in the ceiling.	Use the Spectra Precision marker.		The mark is the centre point for optical plumb adjustments.

fig 3-73



5	Verify that the mark is centred.	Recheck alignment with the tribrach.		
---	----------------------------------	--------------------------------------	--	--

Level adjustments

Performance

Item	Action	Performance	Result	Notes
1	Place the tribrach on a stone table or on a stable bench.			
2	Place the level tool in the tribrach.			
3	Level the tribrach in X- and Y-axis.	Use the footscrews to level the tribrach.		
4	Check and if necessary adjust the level.	Adjust the screws under the level if out of alignment.		

fig 3-74



fig 3-75



Optical plumb adjustment

Performance

Item	Action	Performance	Result	Notes
1	Place the optical adjustment tool in a fixed tribrach.			Make sure there is a reference marker, <i>see Adjustment setup on page 3-62.</i>

fig 3-76



- Place the tribrach on top of the tool.

fig 3-77



Performance

Item	Action	Performance	Result	Notes
3	Check and if necessary align the optical plumb.	Turn the tribrach half a circle and adjust the screws half the error.		

fig 3-78



- 4 Perform item 3 until the optical plumb is aligned.

Tribrach - 571908 823

Adjustments

The laser plumb line is not possible to adjust. It is fixed and shall under normal use never come outside the tolerance. The whole laser unit can be replaced.

Other adjustments are equal to the tribrach 571 905 560/2.



## GPS Antennas

### Compact antenna L1/L2

fig 3-79

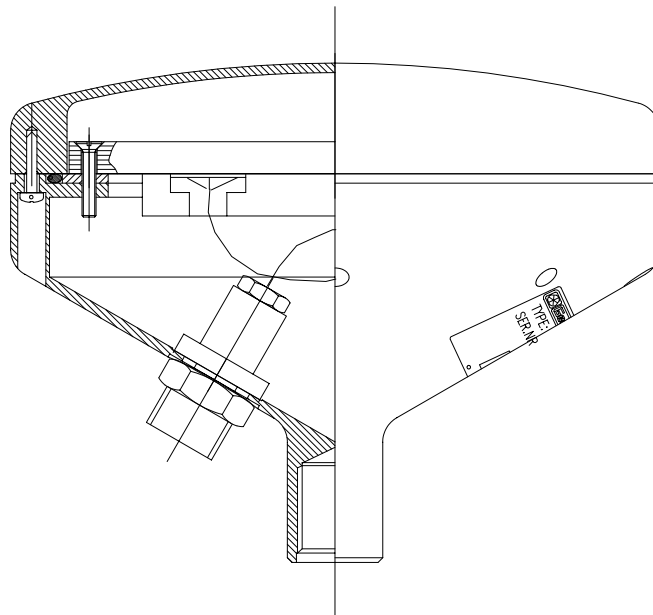

It is important that the antenna element is fitted correctly in relation to the N-Type connector as the drawing describes.

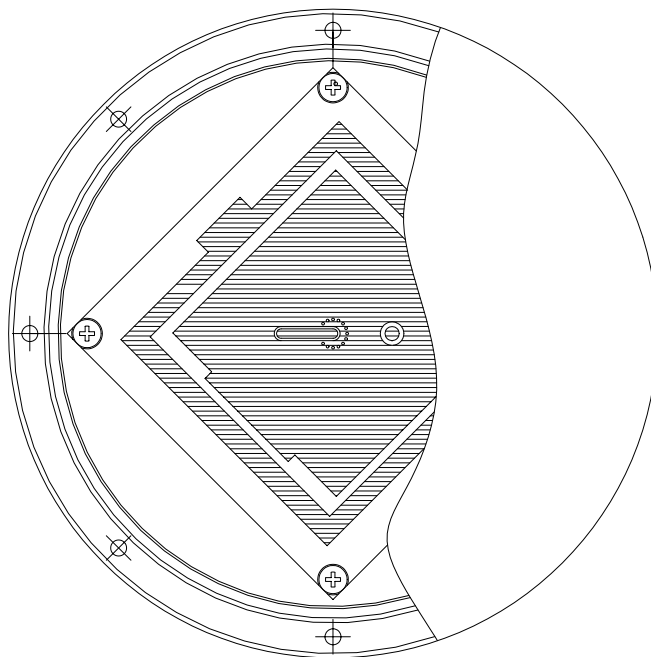

## Geodetic antenna L1/L2

fig 3-80

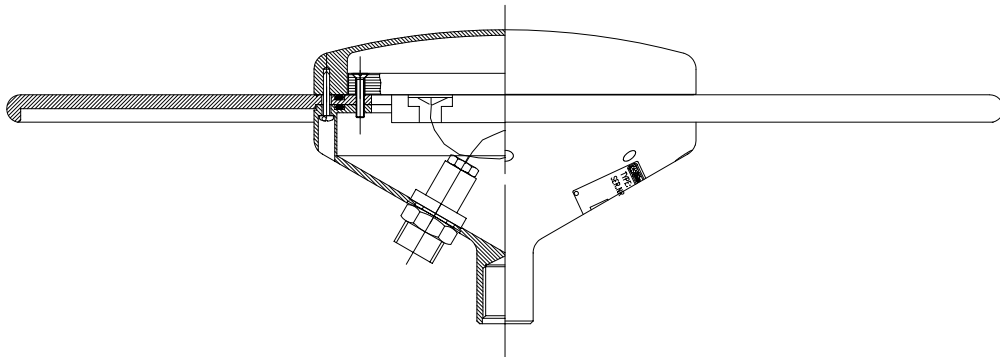

It is important that the antenna element is fitted correctly in relation to the N-Type connector as the drawing describes.

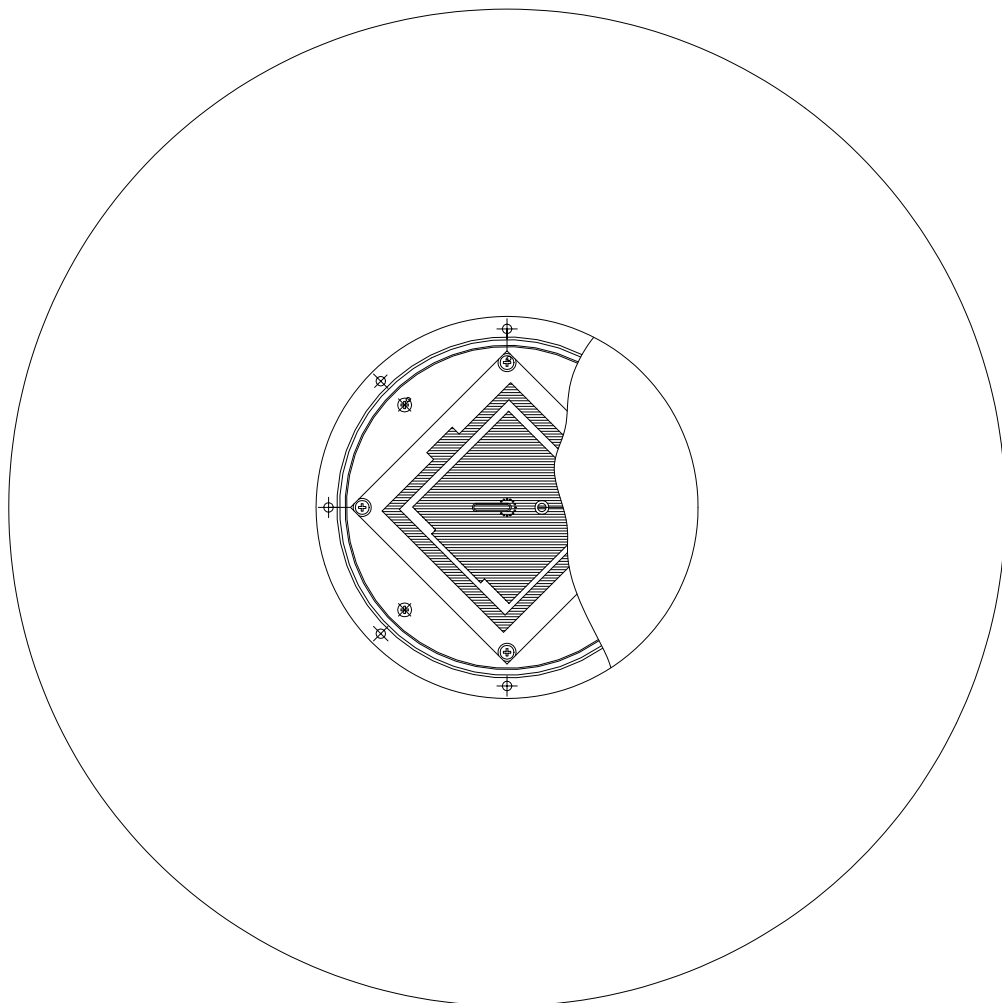

# 4. Component placement

## Holders

## ACU Holder

## CAP2 Board

fig 4-1

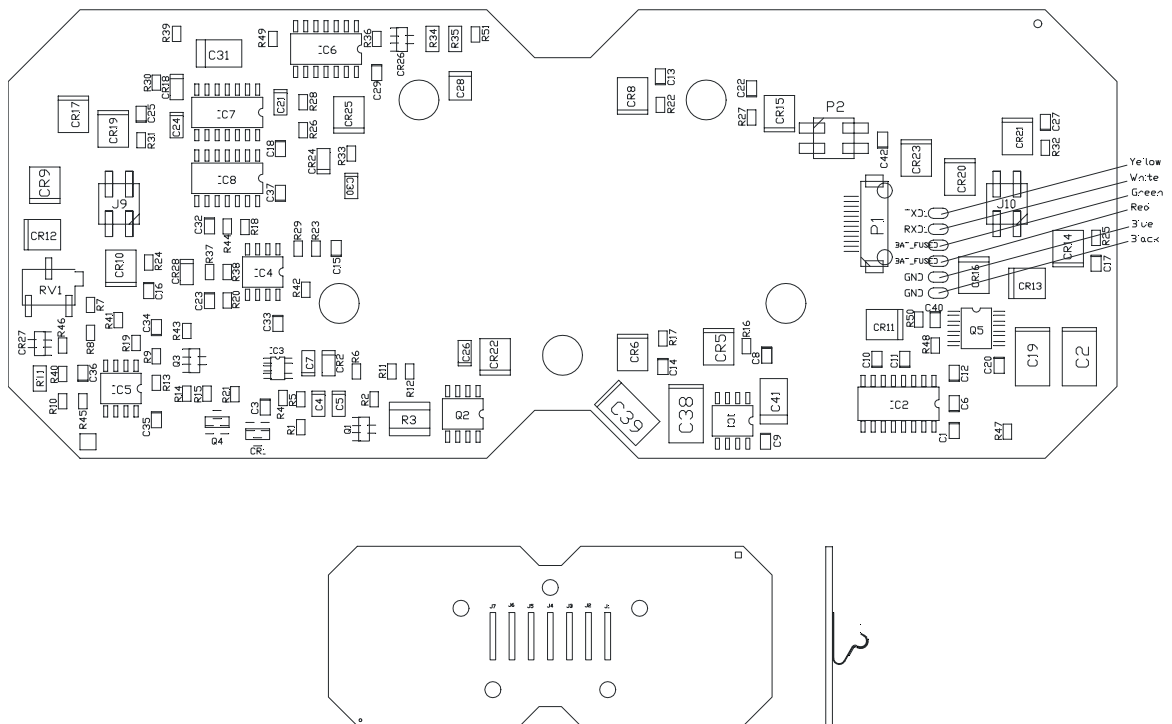

Yellow  
White  
Green  
Red  
Blue  
Black

# BCB2 Board

fig 4-2

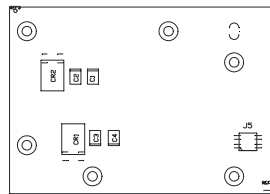
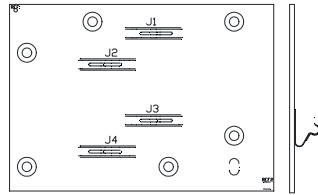

# CU Holder

# CAP Board

fig 4-3

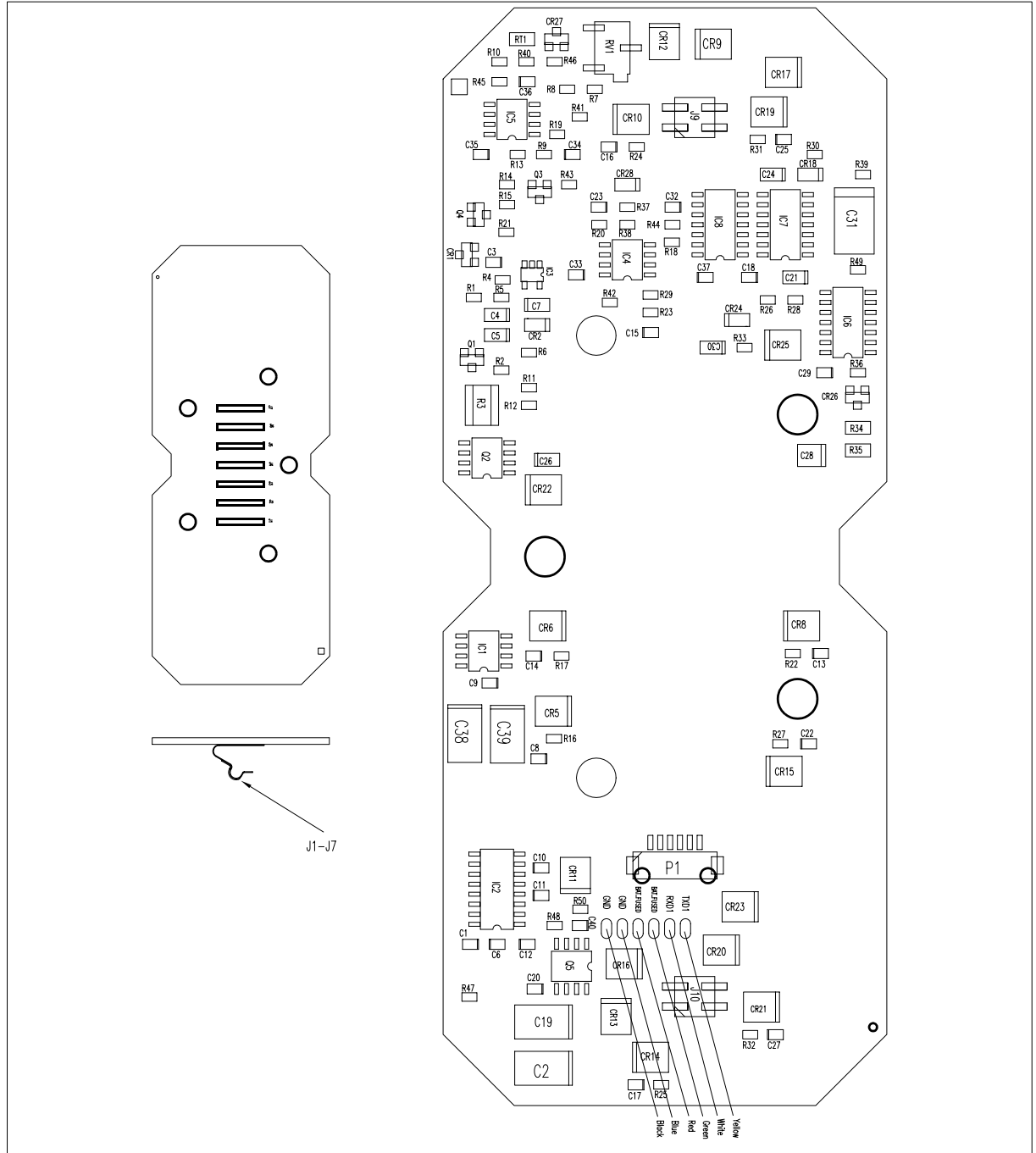

### TBD board

fig 4-4

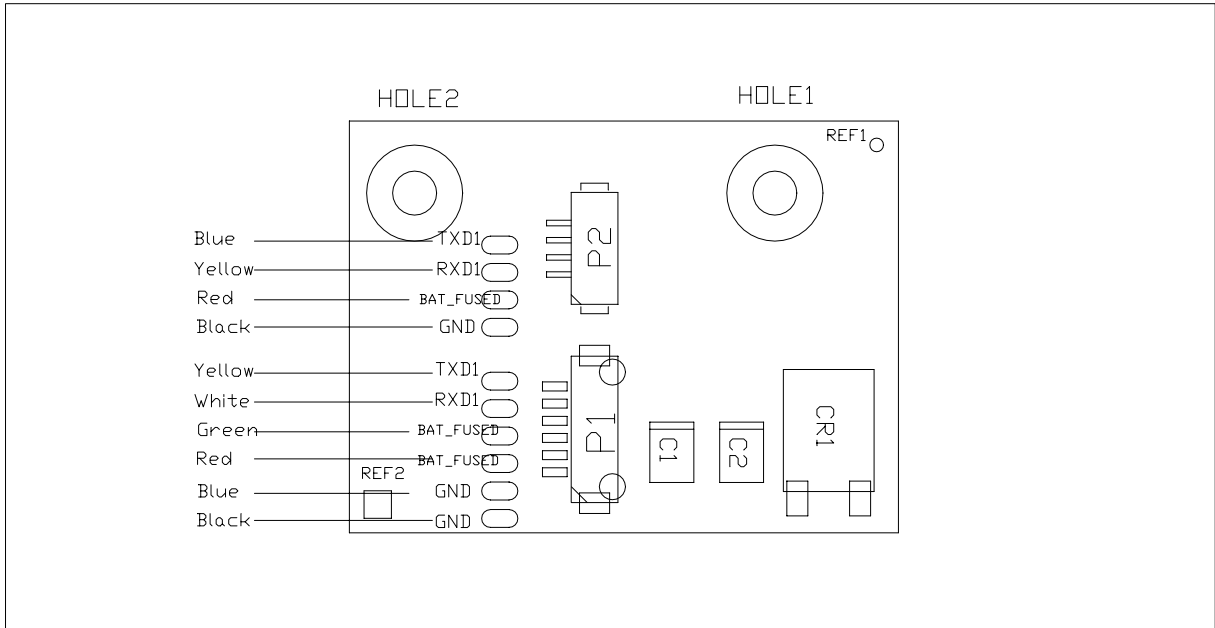

# RMT

## RMT 606 Interconnection diagram

fig 4-5

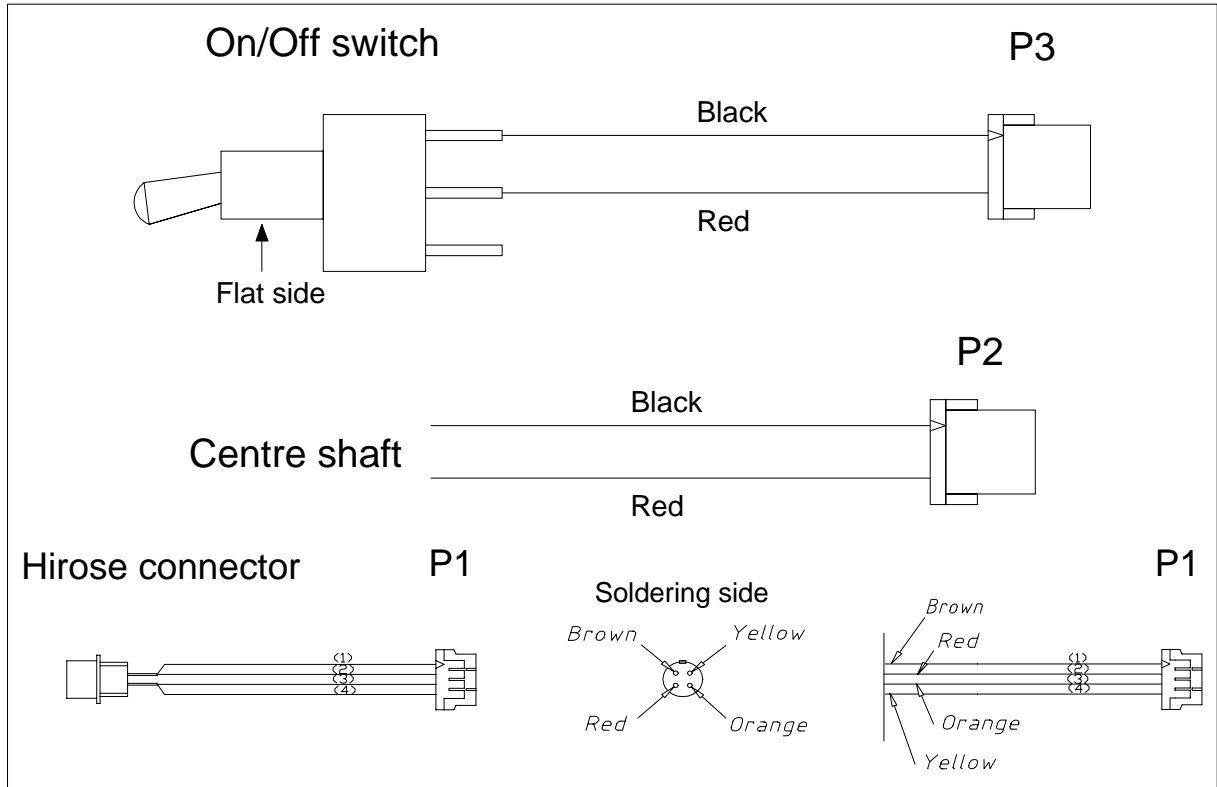

Cable connections, MOD board P1 - Hirose connector

P1	Colour	Function	Hirose connector
1	Brown	Not used	1
2	Red	Ext ON / OFF	2
3	Orange	Ext PWR	3
4	Yellow	GND	4

### Connectors, R15

fig 4-6

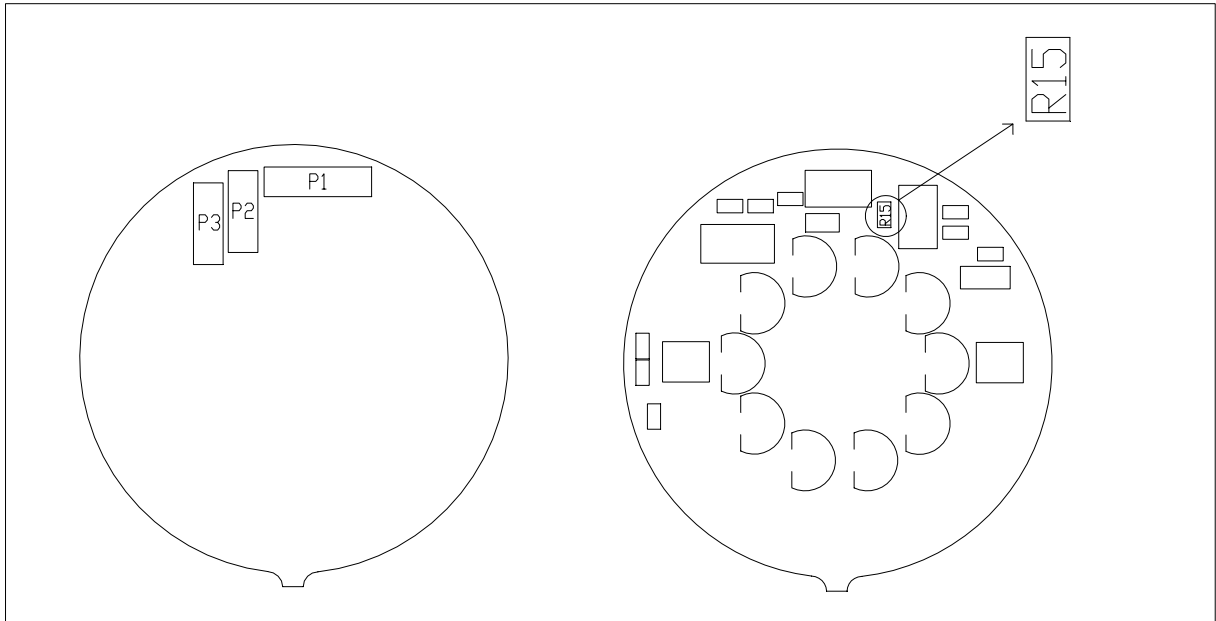



# MOD Board - RMT 606

fig 4-7

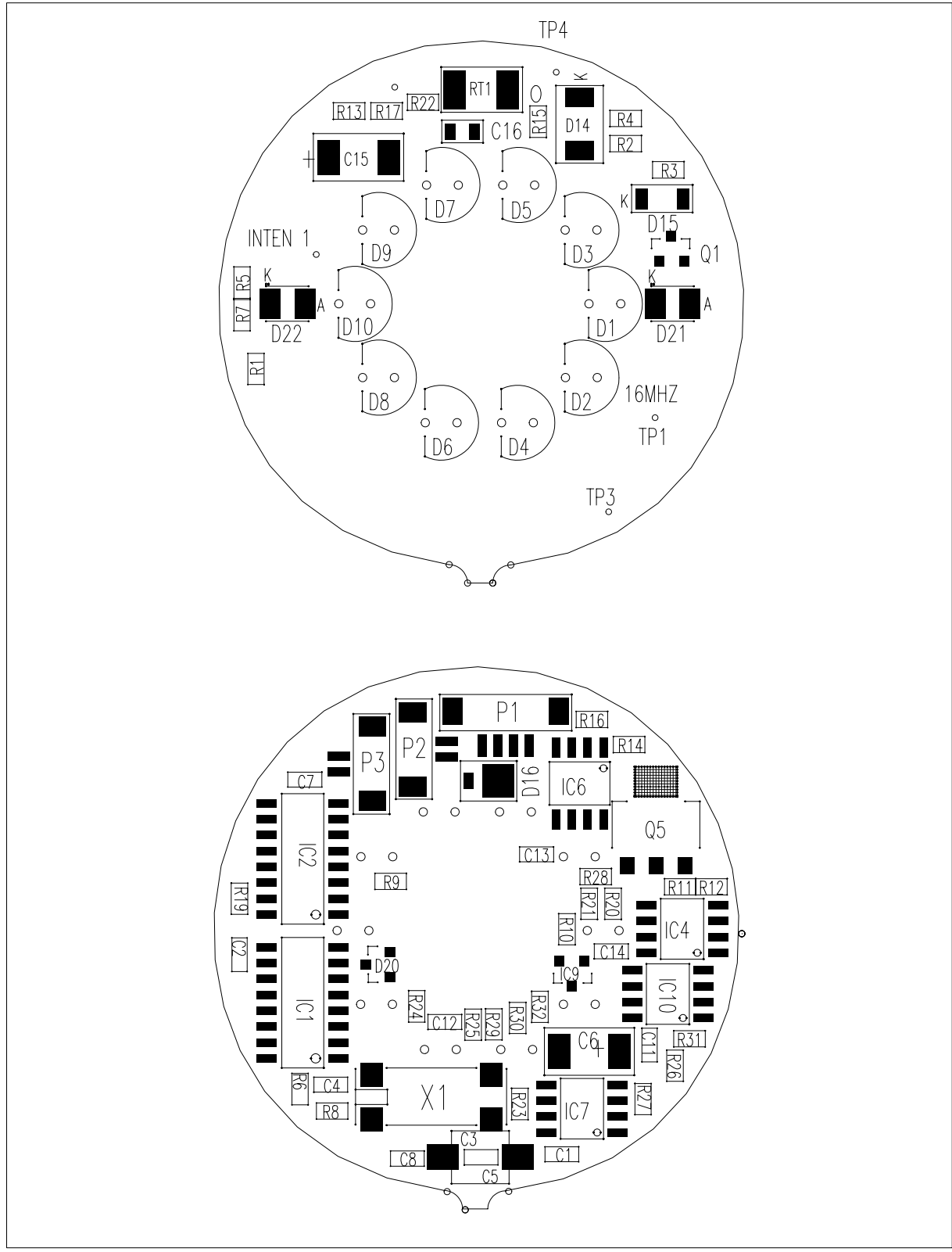

### RMT 604 Interconnection diagram

fig 4-8

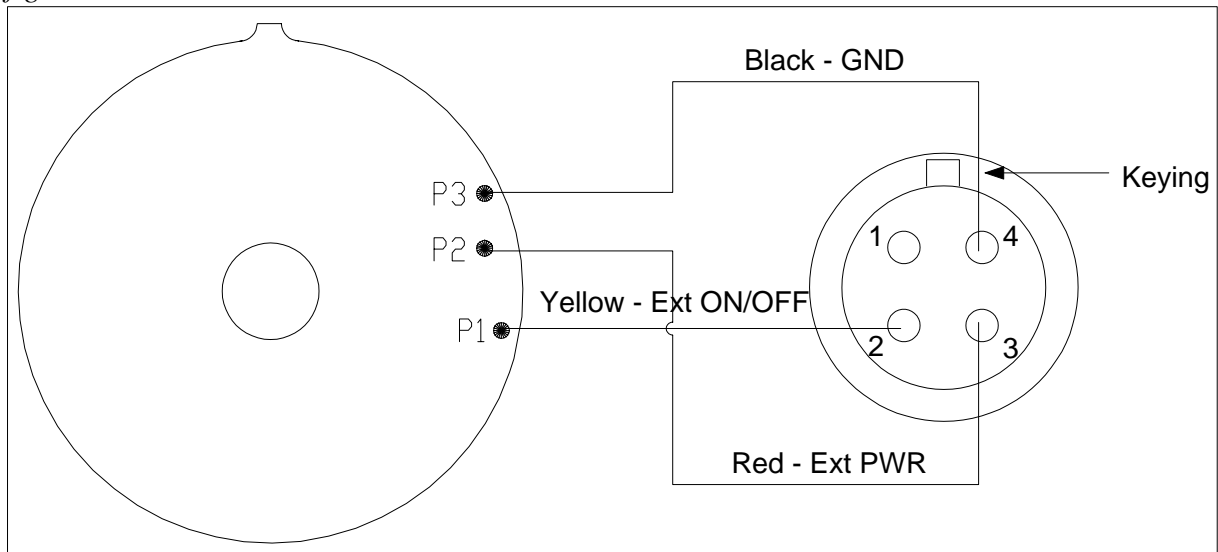

#### Cable connections, MOD board - Hirose connector

MOD board	Colour	Function	Hirose connector
P1	Yellow	Ext ON / OFF	2
P2	Red	Ext PWR	3
P3	Black	GND	4

# MOD Board - RMT 604

fig 4-9

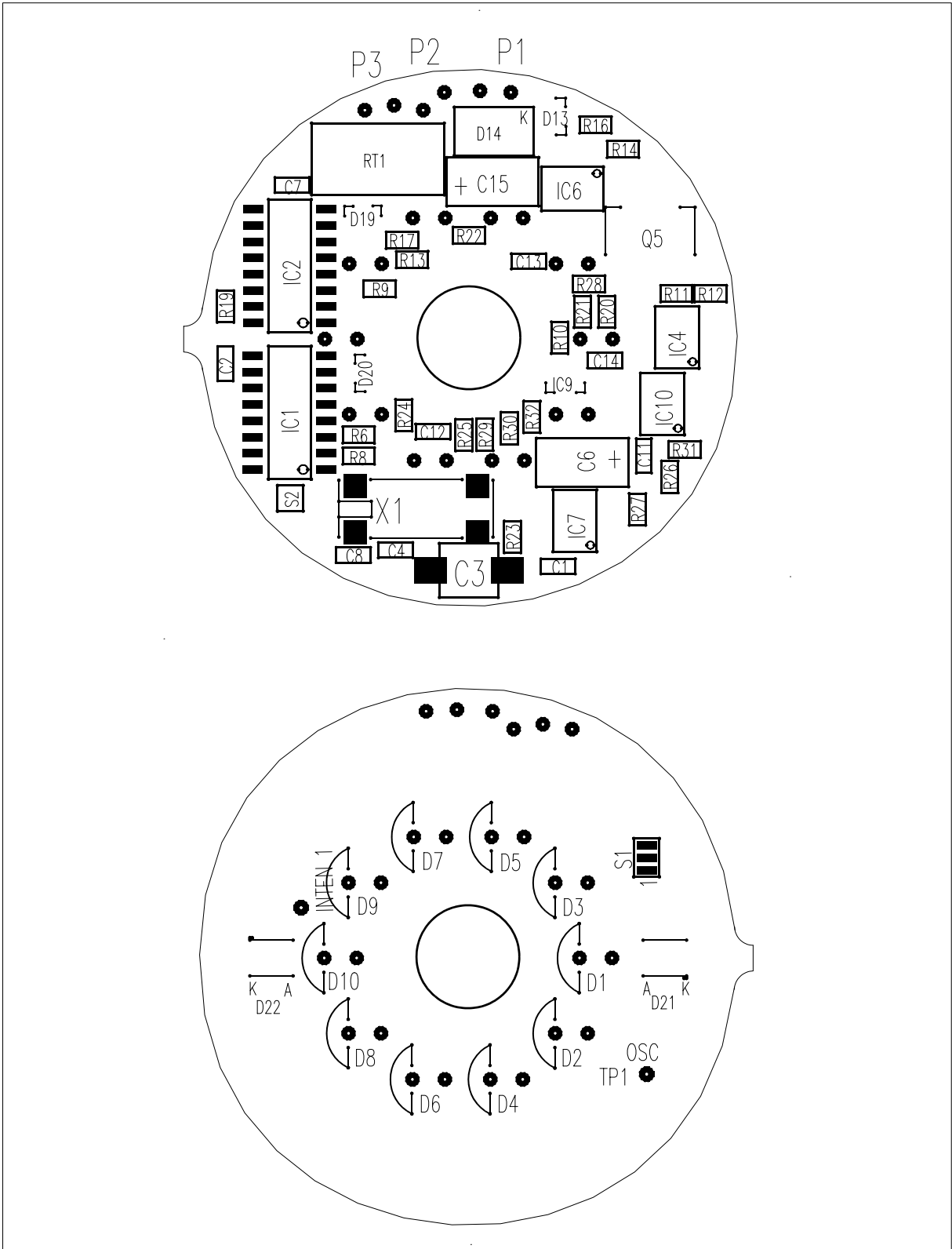

### BBR2 Board

fig 4-10

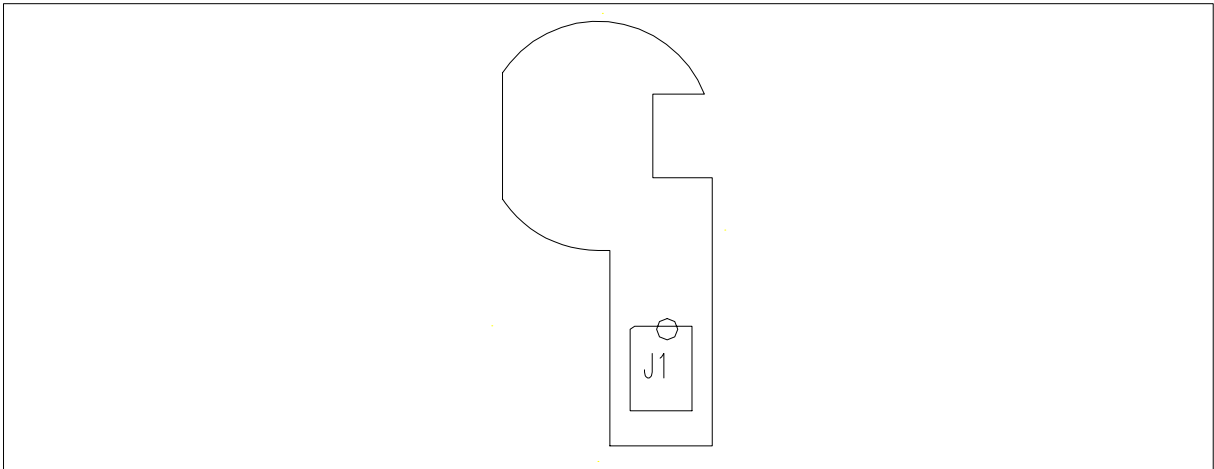

### ESF Board

fig 4-11

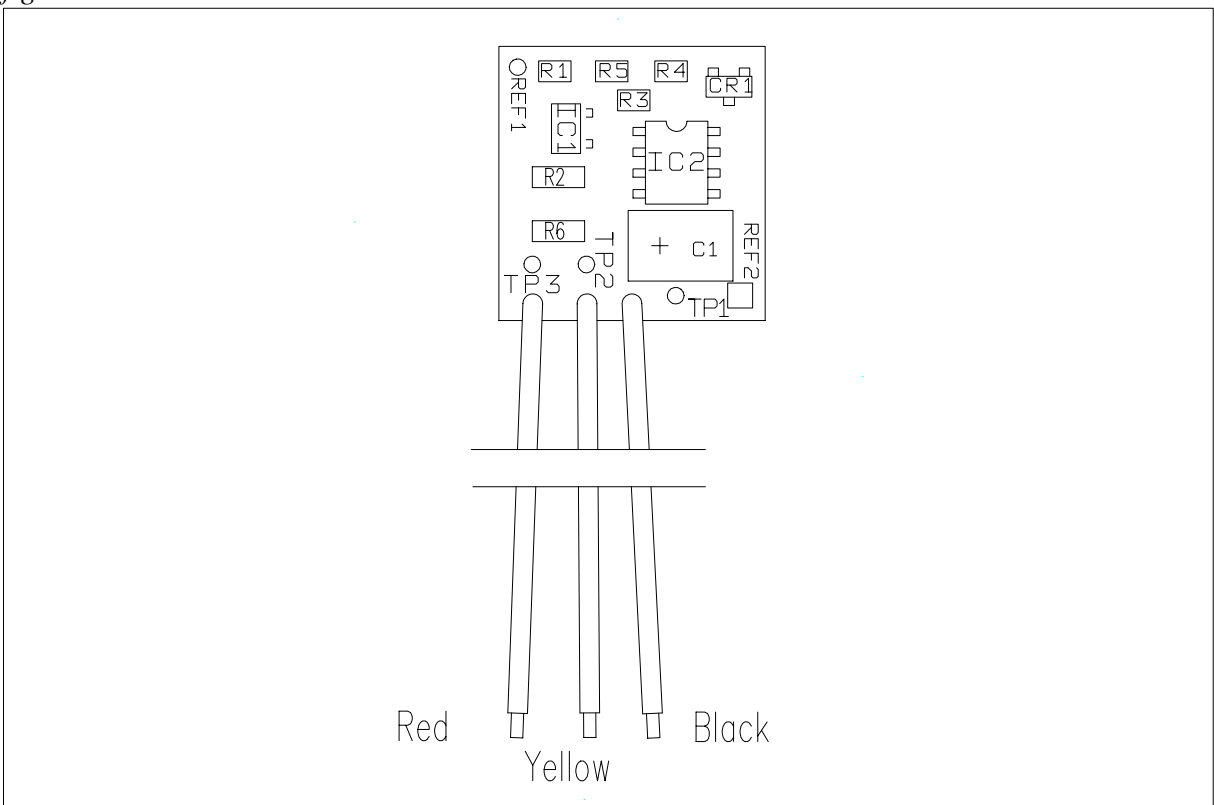

# FRT Board

fig 4-12

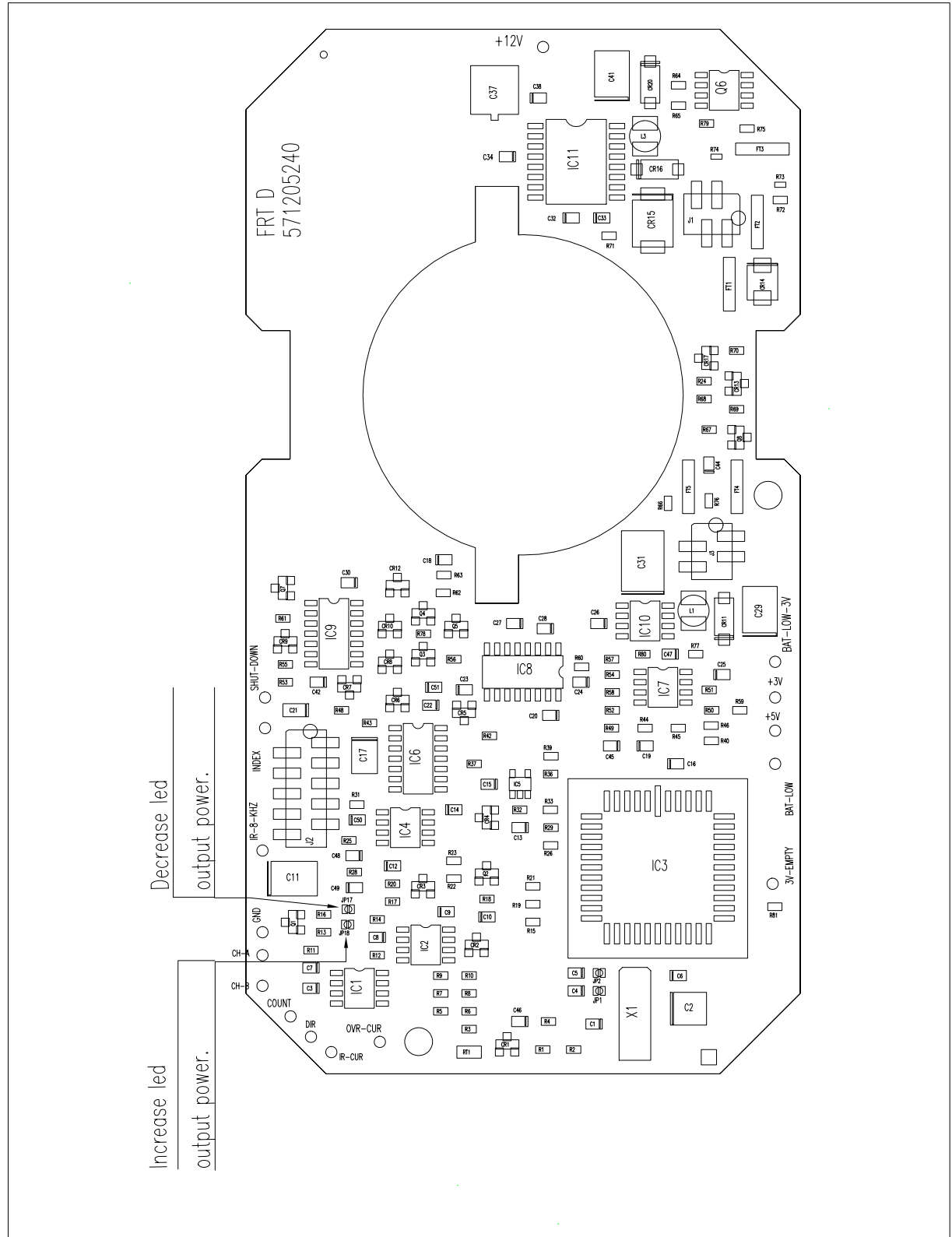
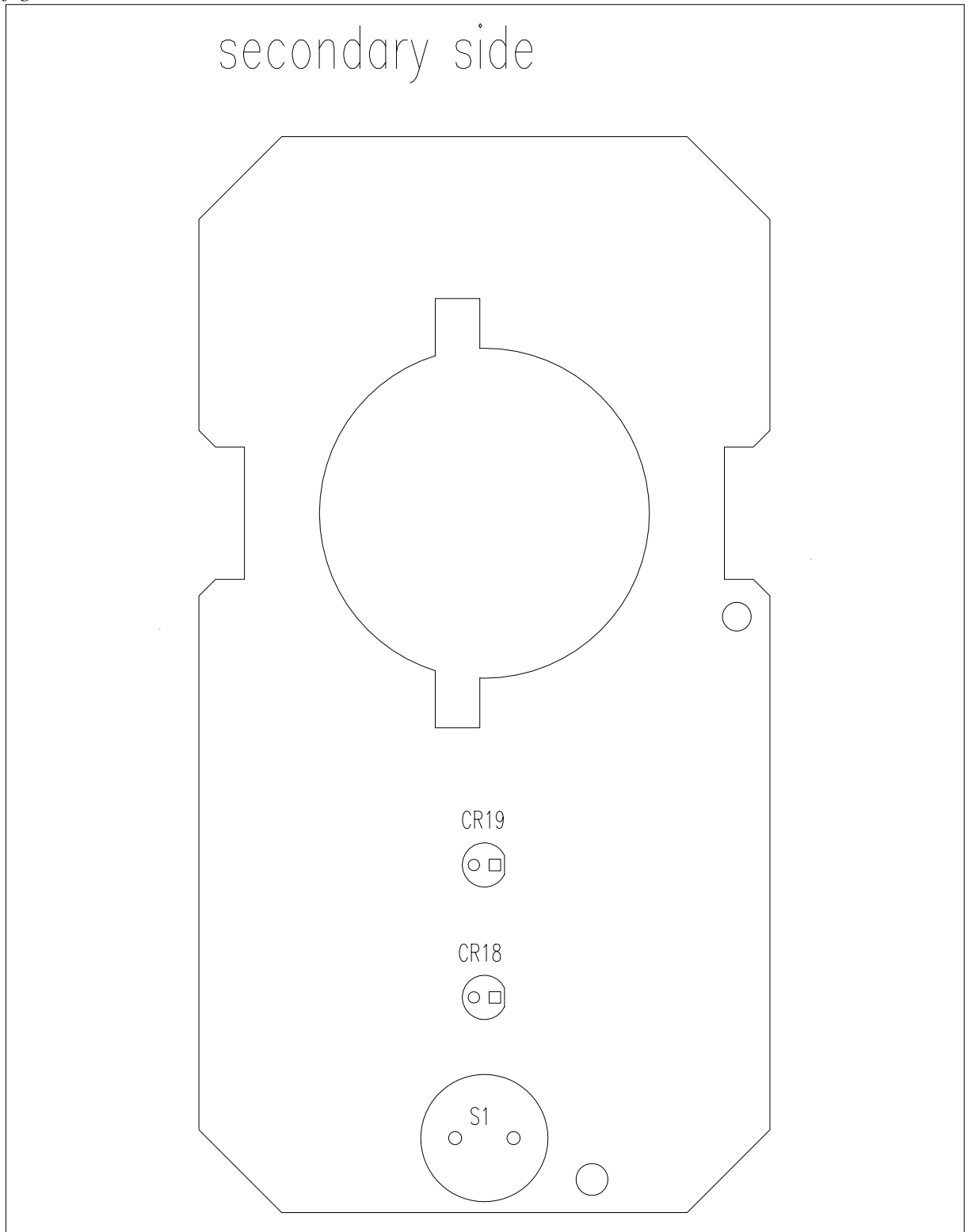
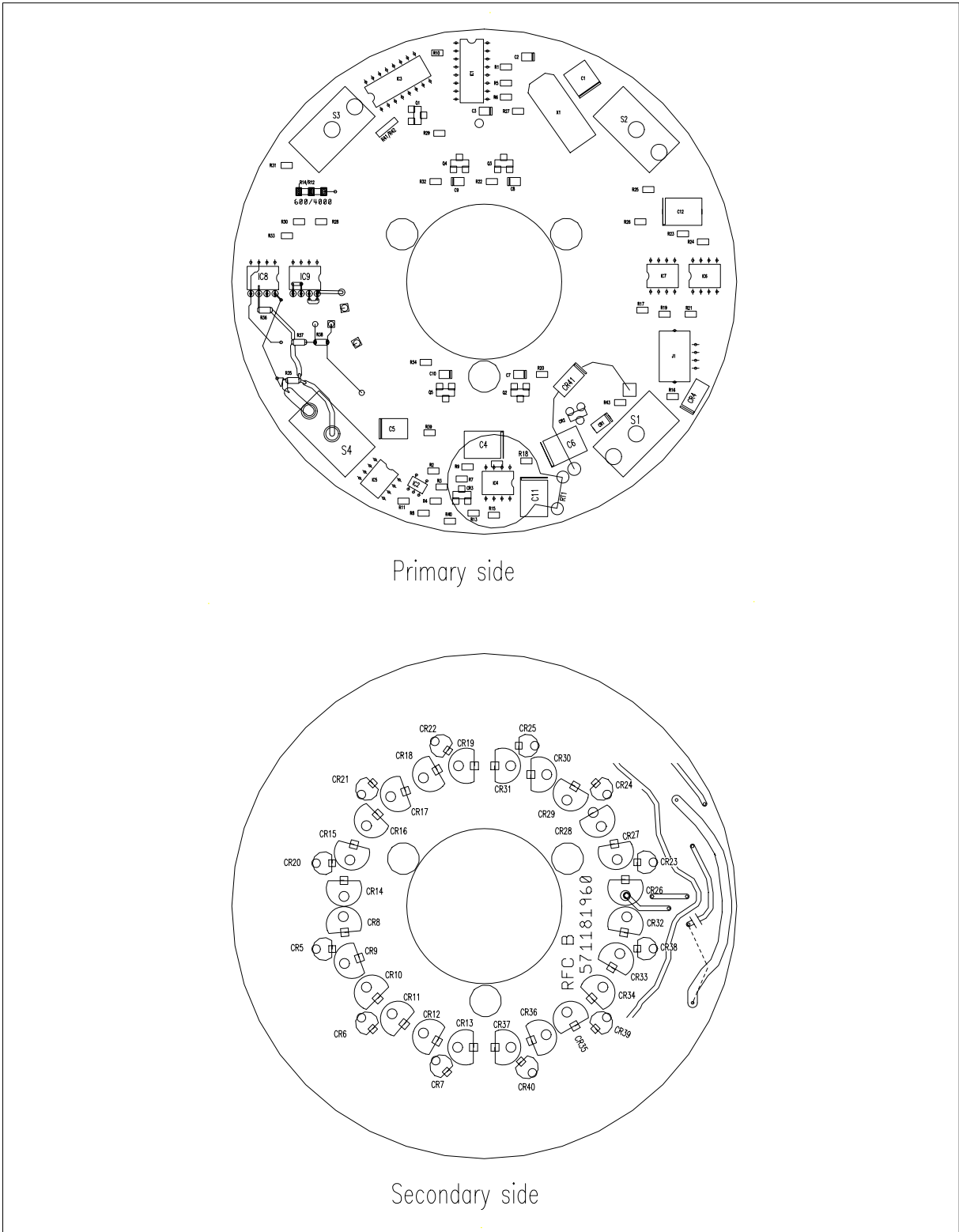

fig 4-13



# RFC Board

fig 4-14



# RFCM Board

fig 4-15

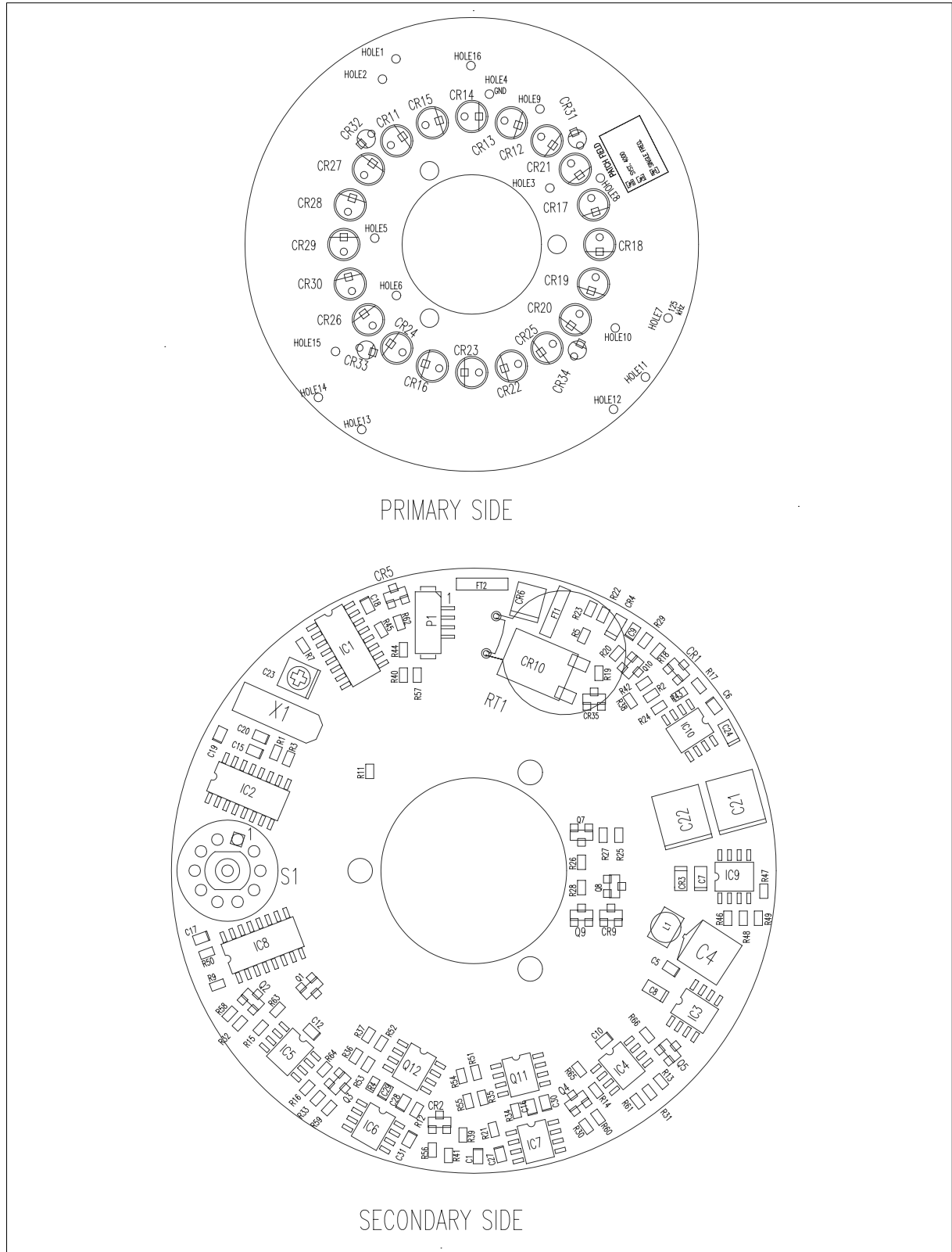



### RMT 4000/4000 LR Interconnection diagram

fig 4-16

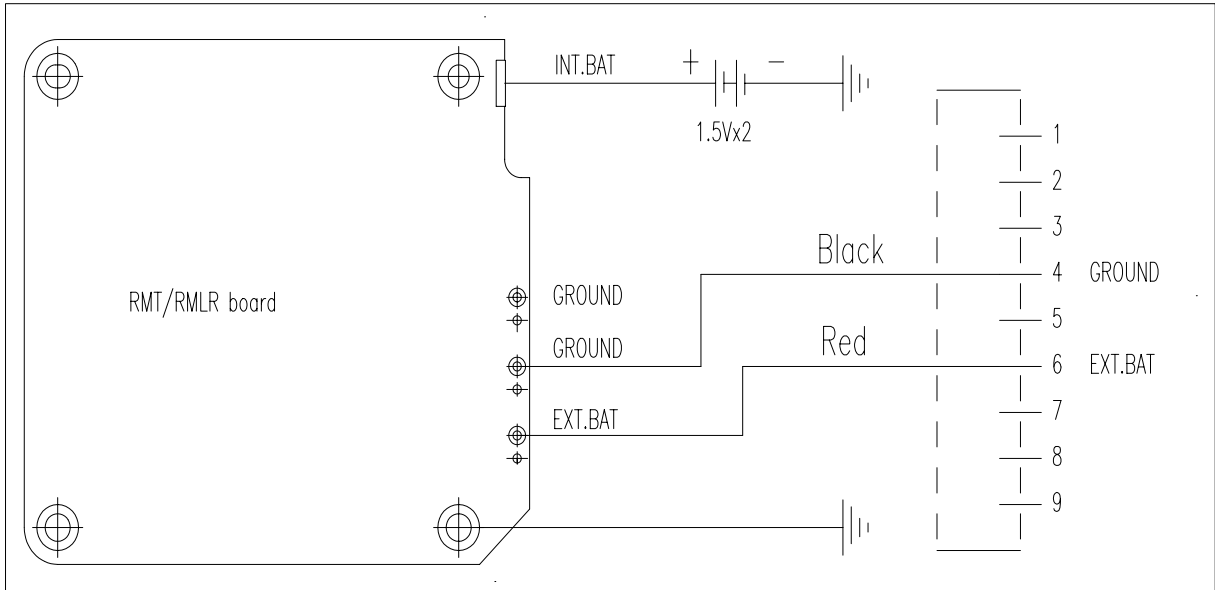

### RMT 600 Interconnection diagram

fig 4-17

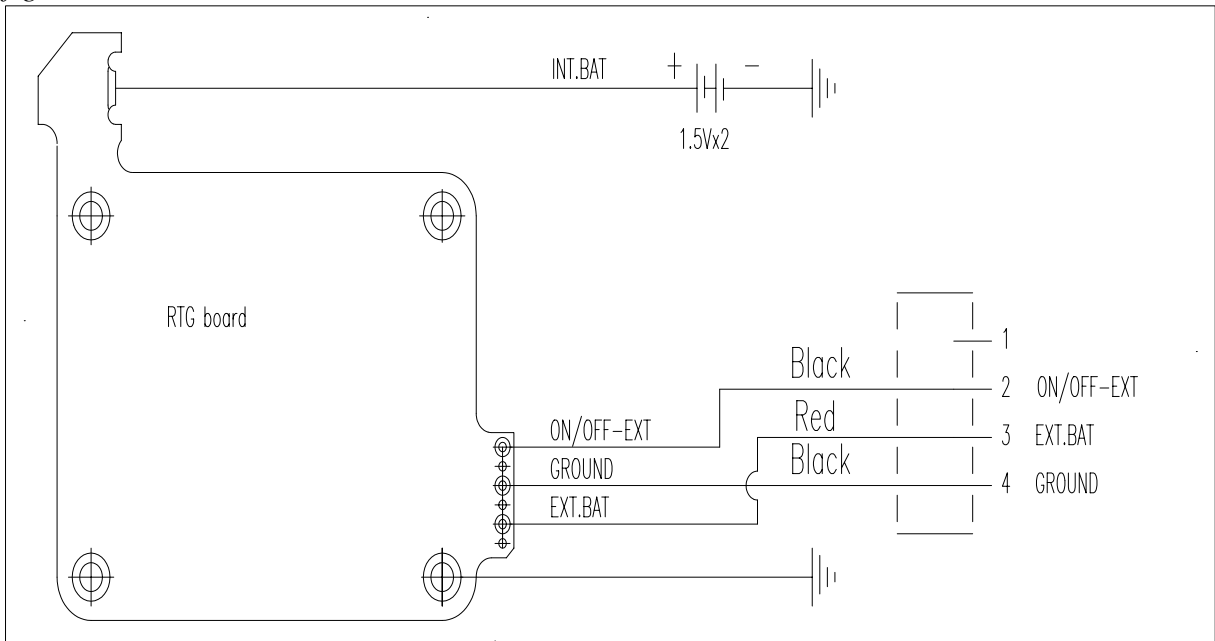

# RMT 600 LR Interconnection diagram

fig 4-18

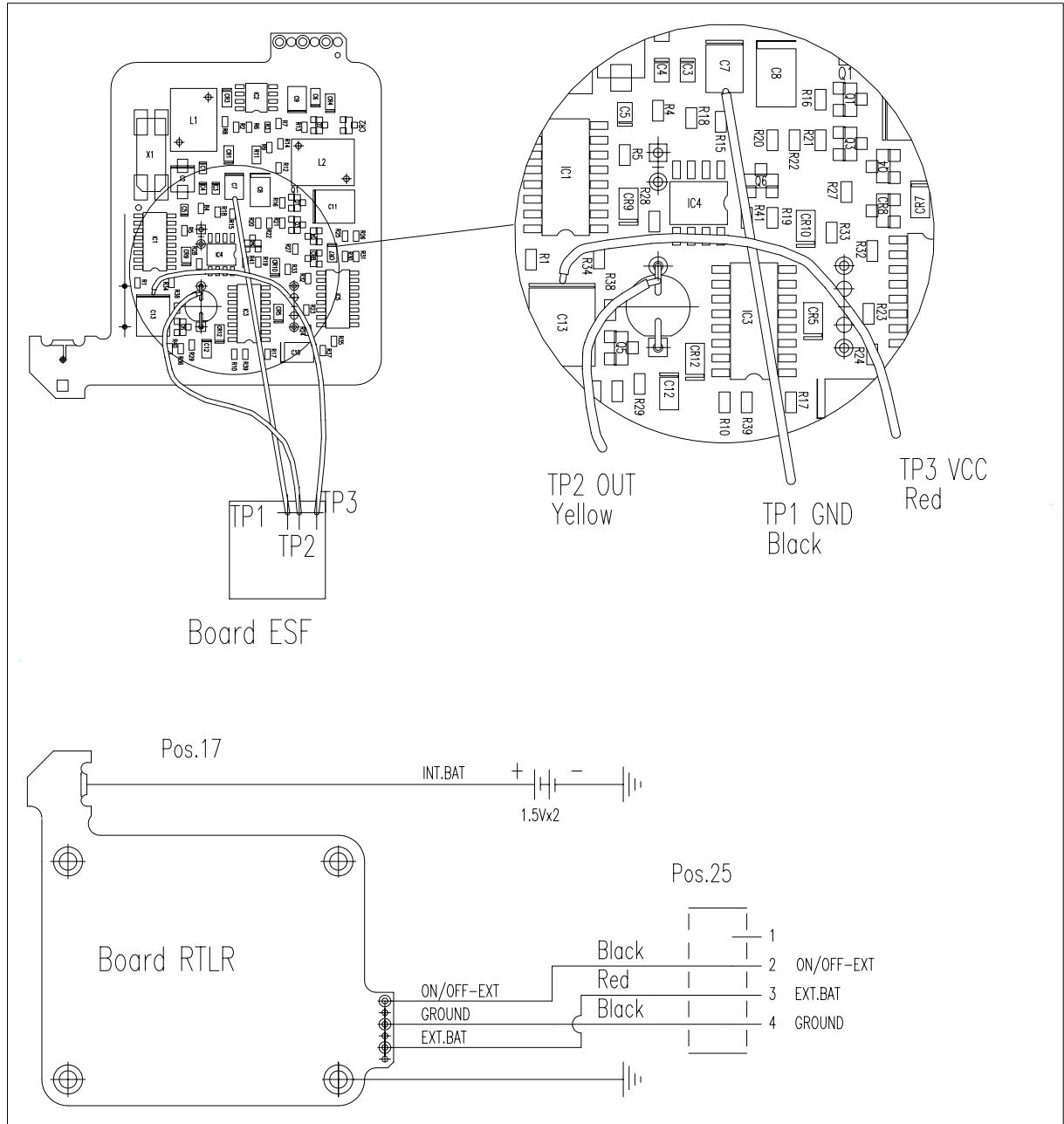

# RMT/RMLR Board

fig 4-19

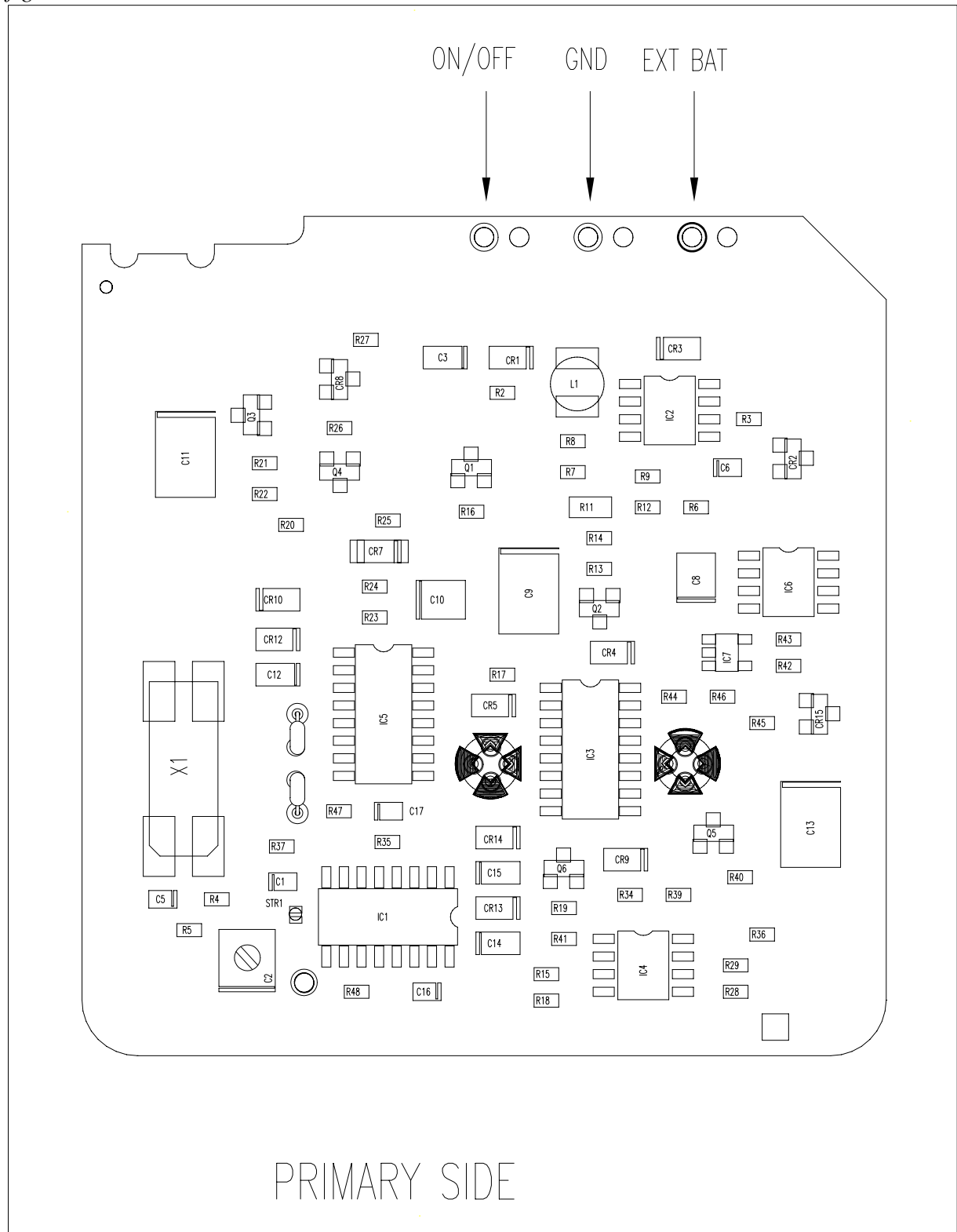
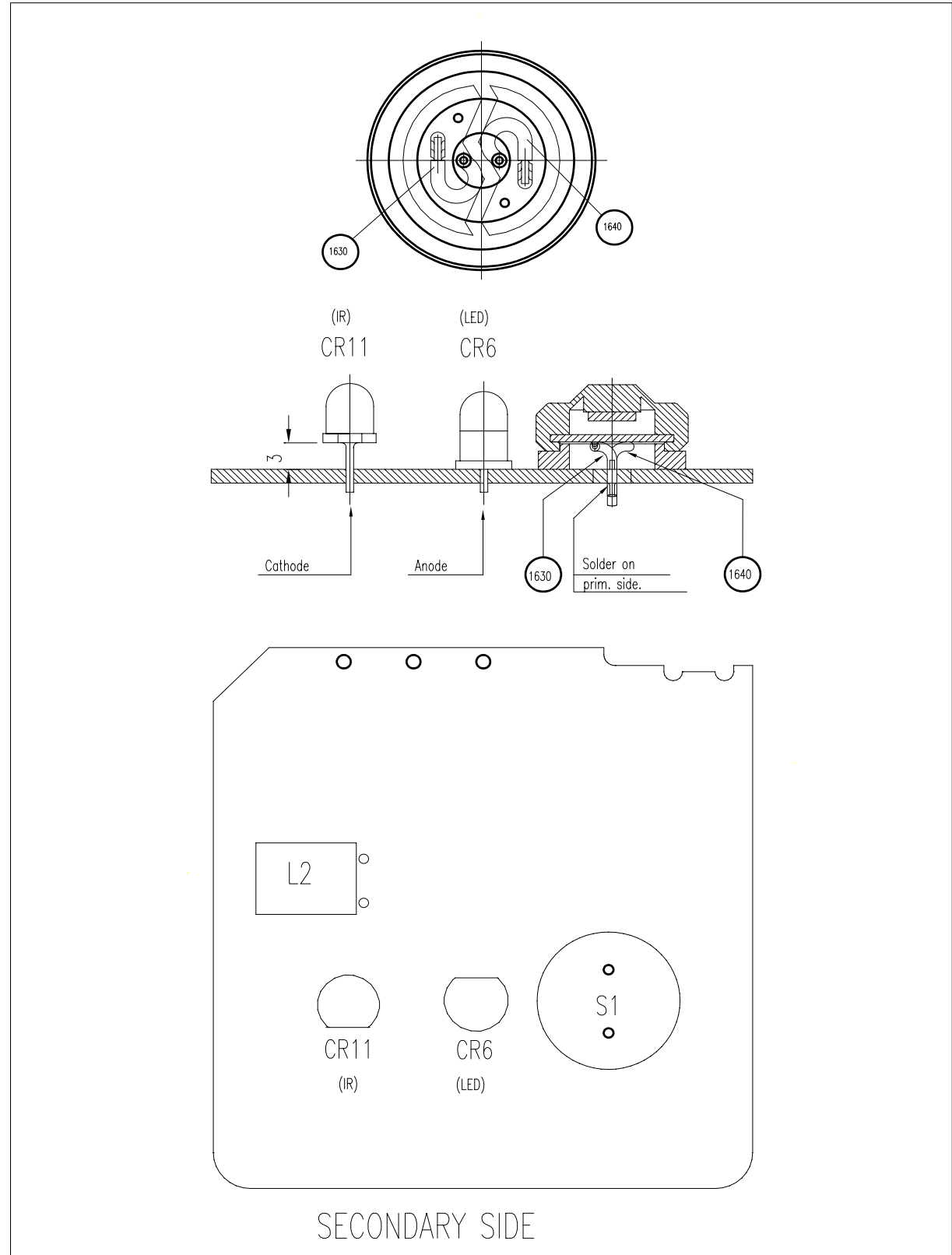

fig 4-20



# RMTSL Board

fig 4-21

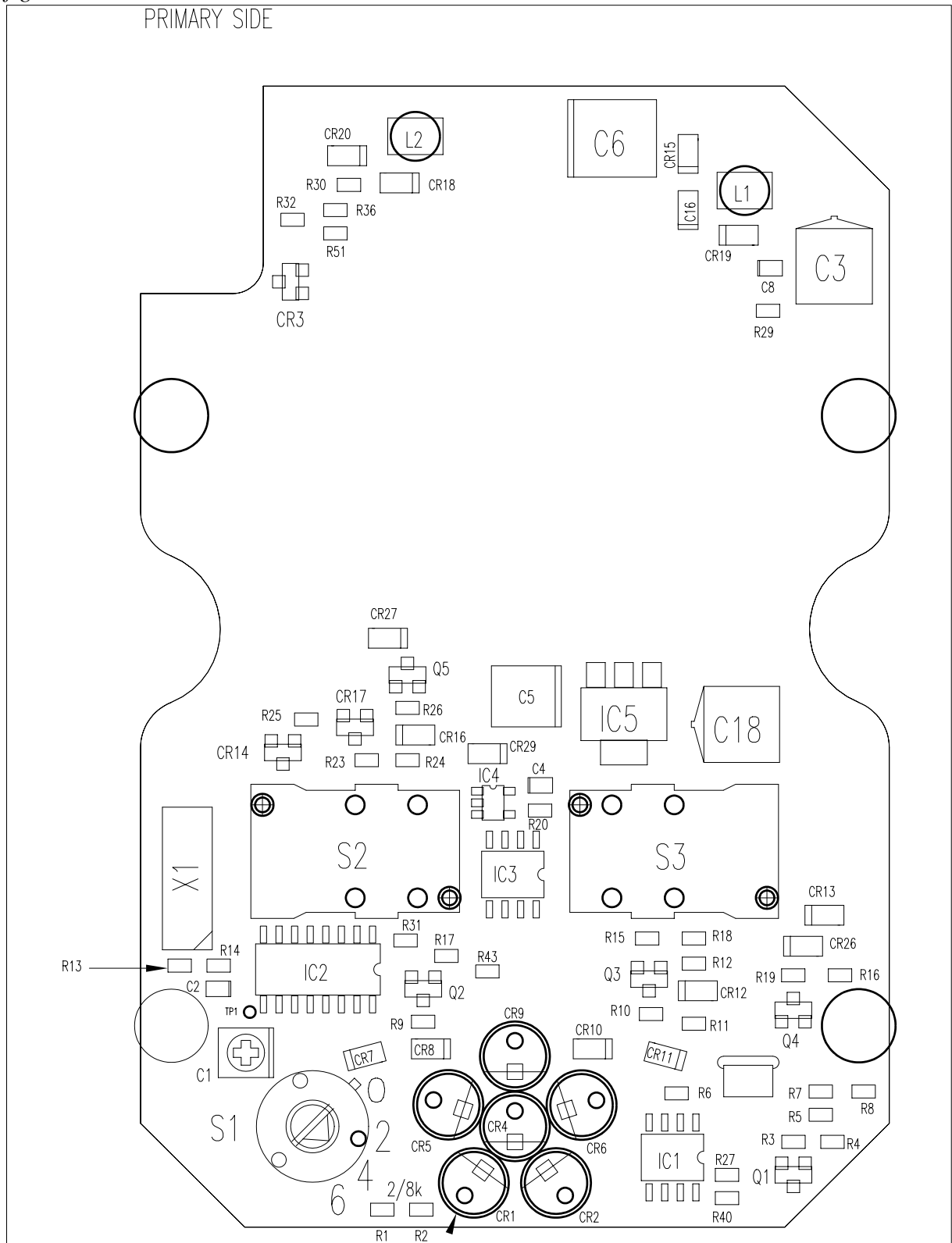
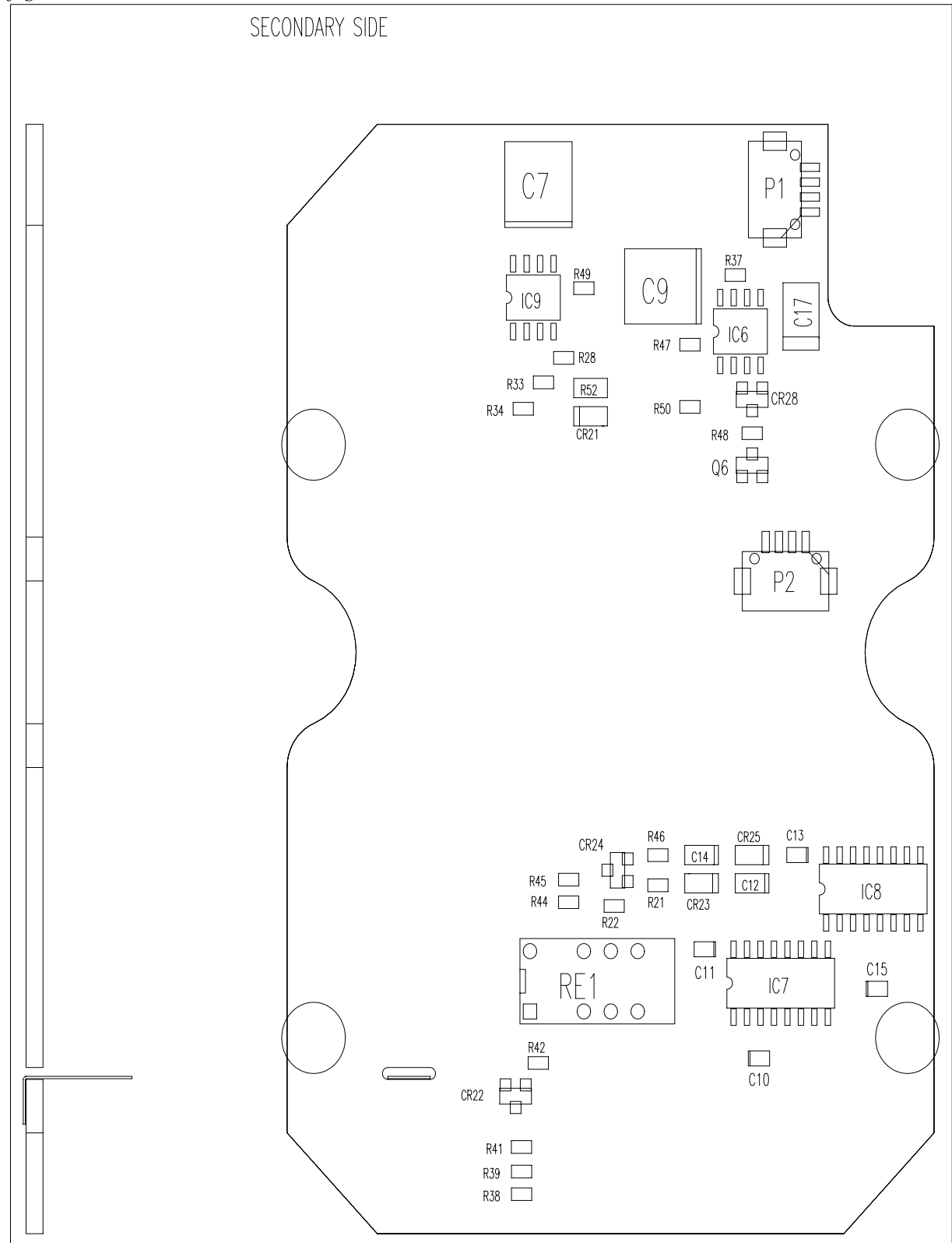

fig 4-22



# RTG/RTL Board

fig 4-23

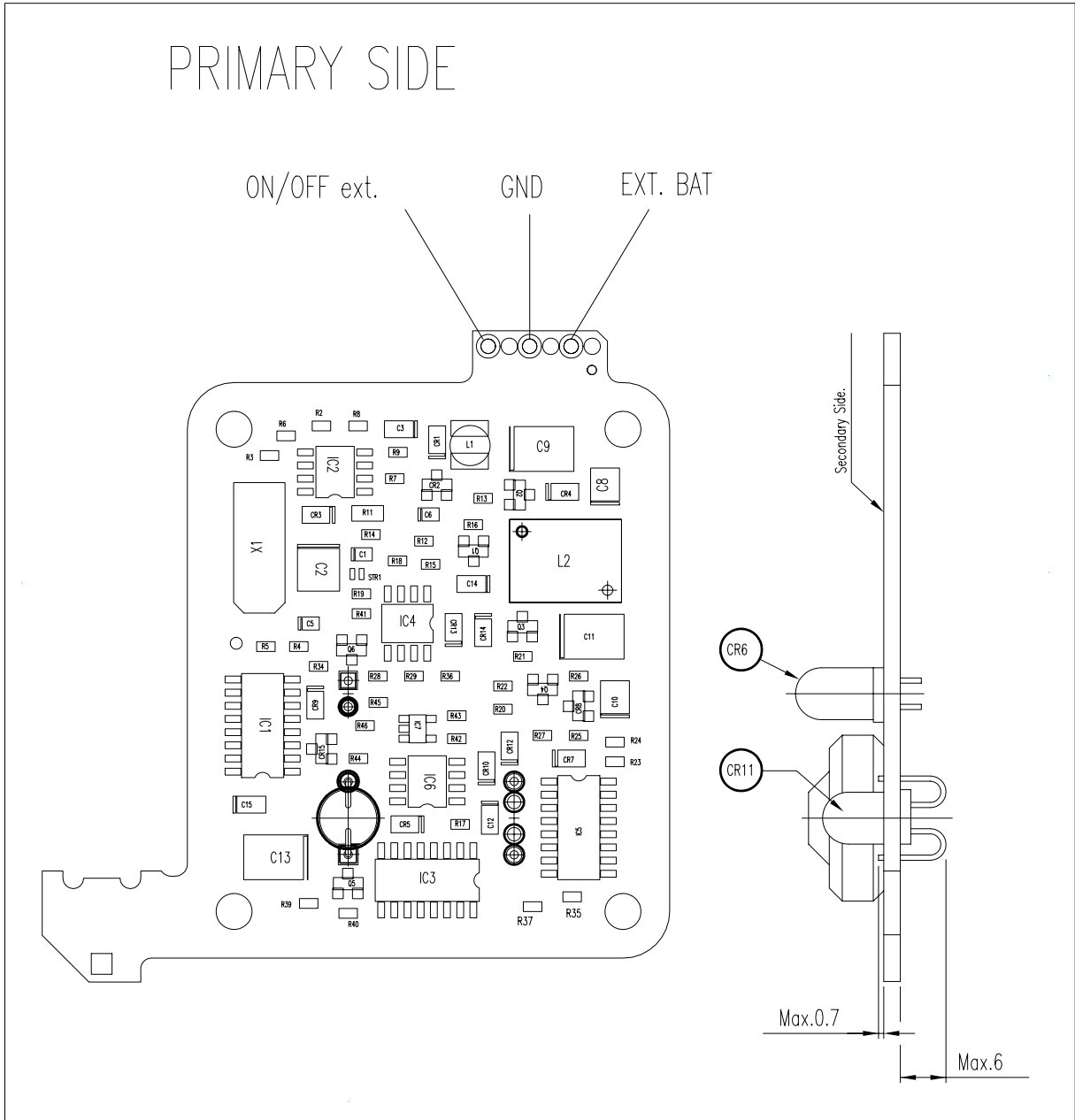
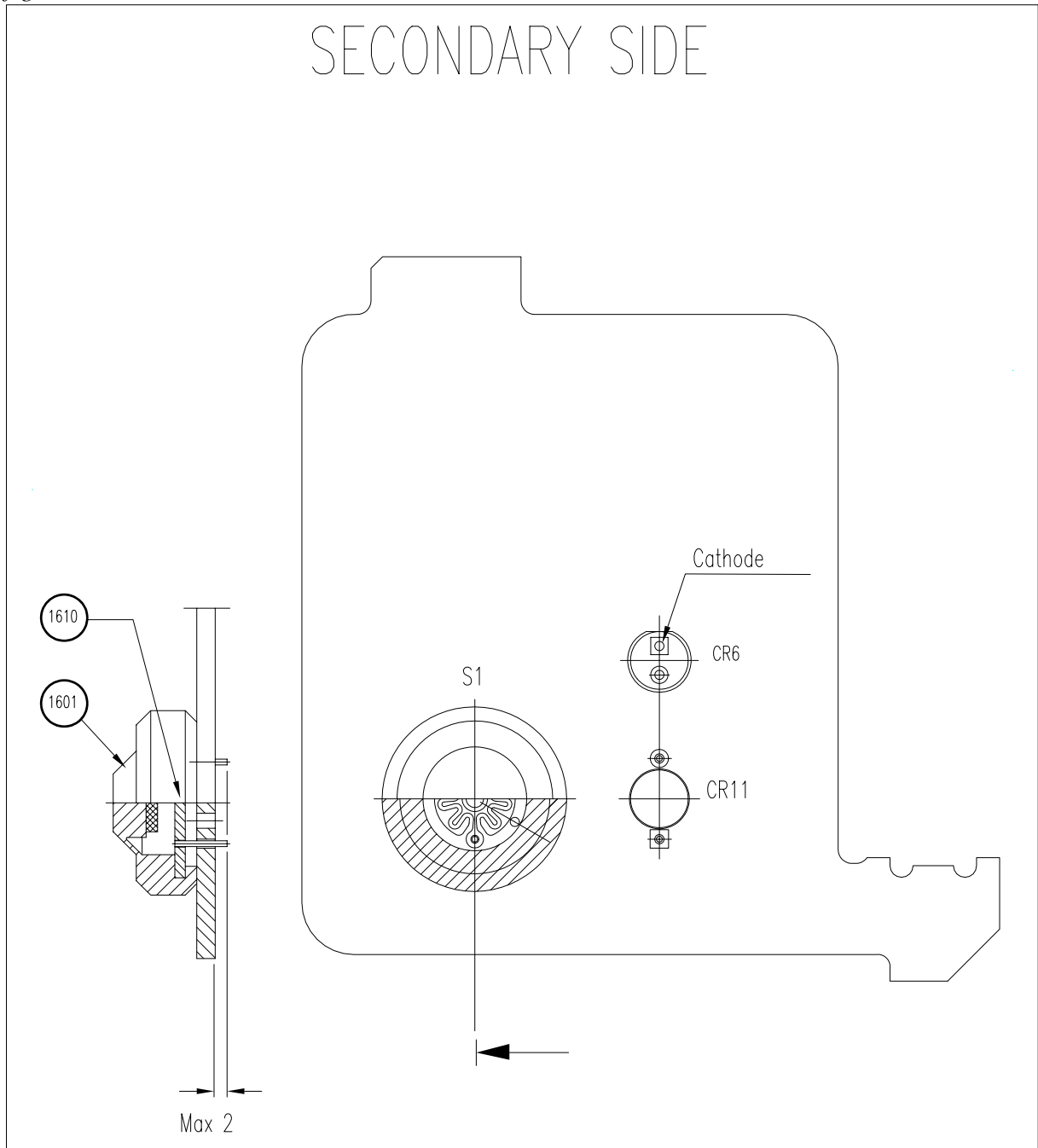

fig 4-24





# RTLr Board

fig 4-25

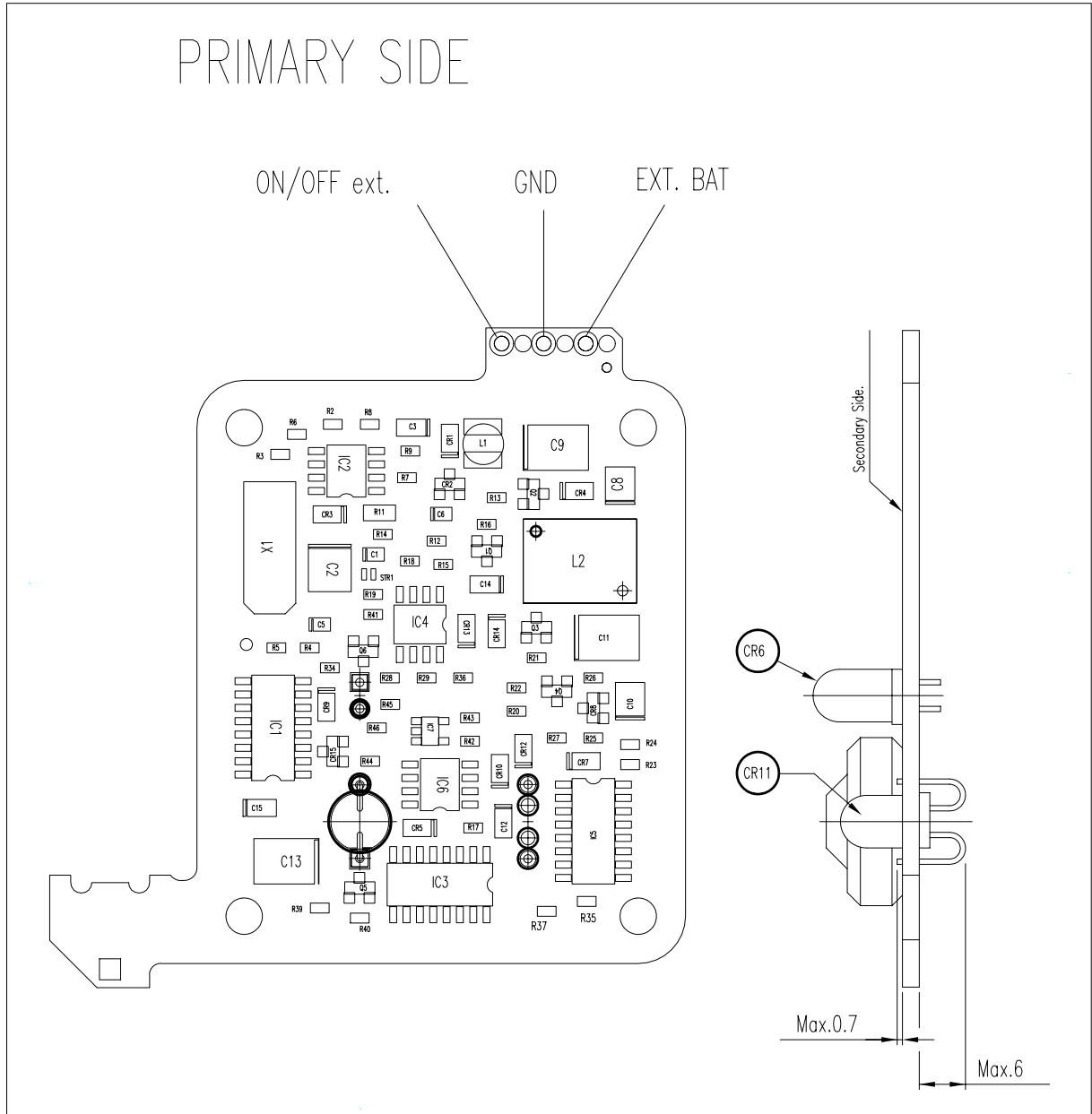
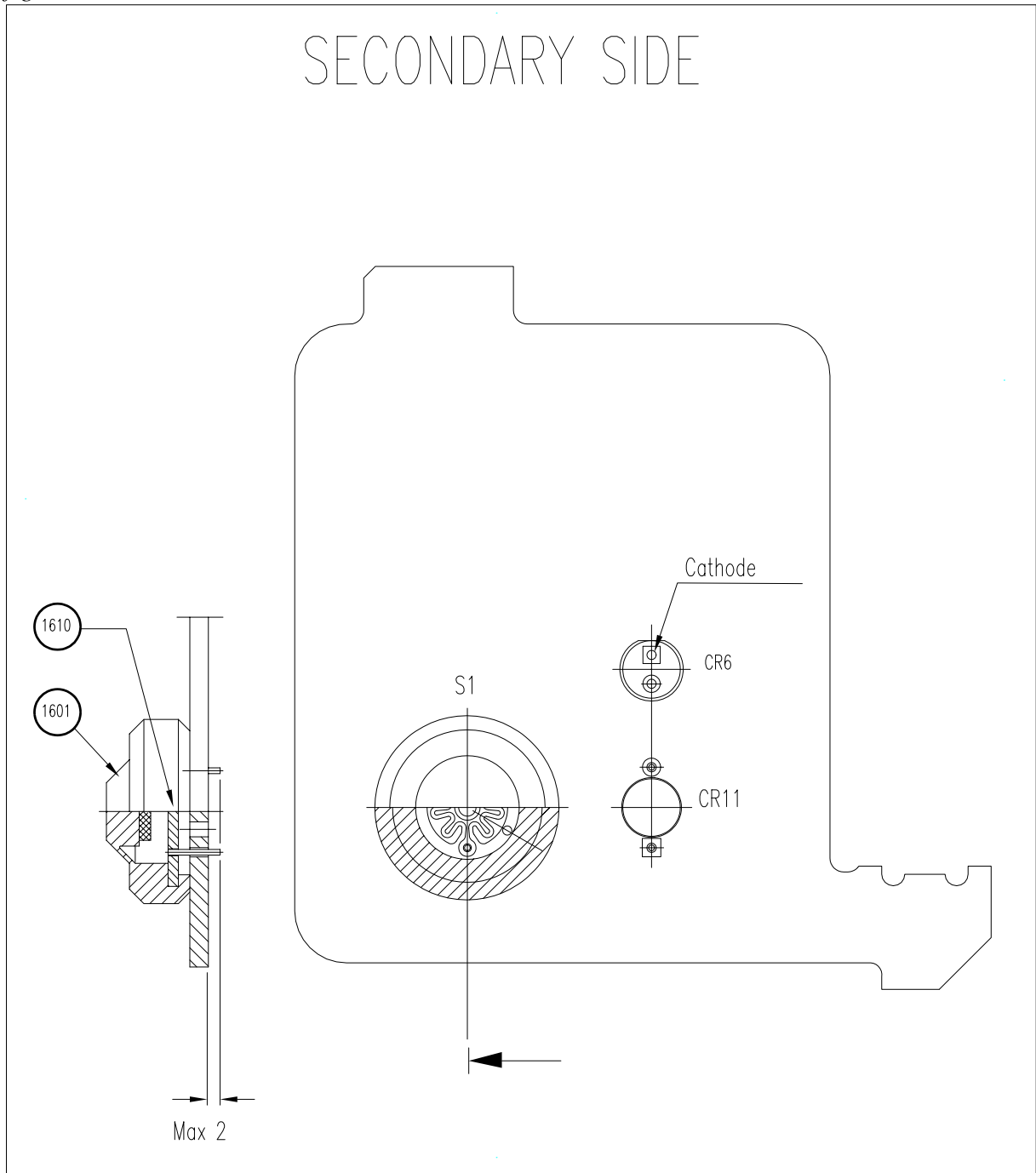

fig 4-26



## 5. Spare parts

### Batteries

#### Power stick - 571 126 277

fig 5-1



Power stick - 571 126 277

Pos.	Description	Part.no:	Pcs.
10	Tip 5/8" incl. screws	R71 127 325	1

There are no other spare parts. The power stick is replaced as a complete unit.

#### Power stick - 571 126 287

fig 5-2



There are no spare parts. The power stick is replaced as a complete unit.

### 5600 internal battery - 571 242 460

fig 5-3



5600 internal battery - 571 242 460

Pos.	Description	Part.no:	Pcs.
10	Battery indicator (10 p)	R71 180 045	1
20	Gable battery 5600	R71 242 074	1

There are no other spare parts. The battery is replaced as a complete unit.

### Radio battery/External battery - 571 204 270

fig 5-4



#### Spare parts

There are no spare parts. The battery is replaced as a complete unit.

# Battery adapter

## Multi adapter - 571 204 273

fig 5-5

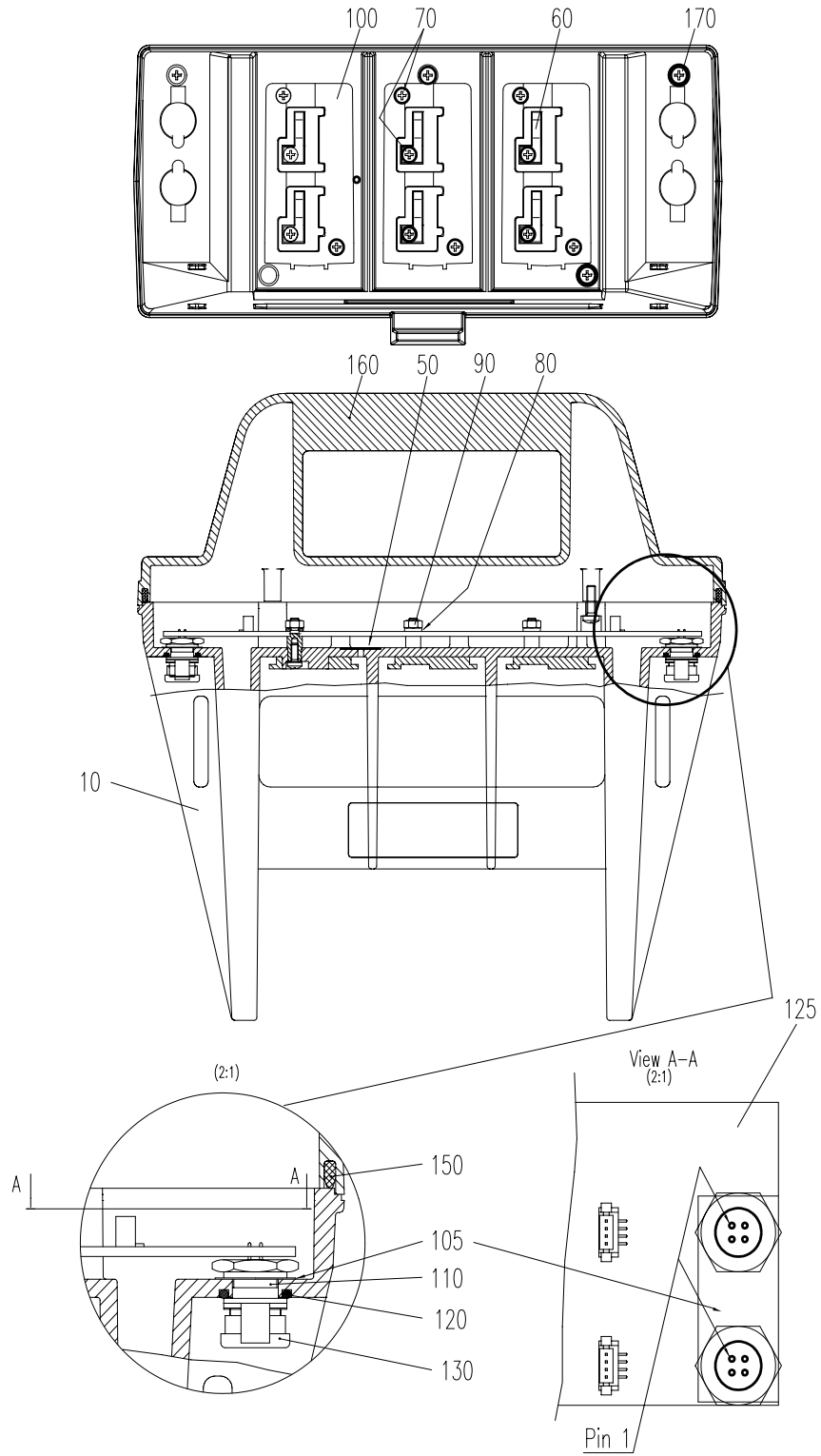

## Multi adapter - 571 204 273

Pos.	Description	Part.no:	Pcs.
10	Multi adapter chassis	R71 204 252	1
50	Gore-tex valve	R71 908 466	1
60	Battery connector spring	R71 202 276	6
70	Screw, 2,5 x 6	571 903 074	12
80	Locking washer	571 901 652	6
90	Nut, M3	941 680 310	6
100	Battery holder plate	R71 202 255	3
105	Hirose connector plate	N/A	2
110	Hirose connectors	R71 905 745	4
120	O-ring, 9,1 x 1,6	R71 908 004	4
125	TAB board	R71 205 300	1
130	Rubber cover for Hirose connector	R71 202 203	4
150	Seal for Multi adapter lid	R71 204 254	1
160	Multi adapter lid	R71 204 251	1
170	Screw, 3 x 10	571 905 782	5

### Single adapter - 571 204 256

fig 5-6

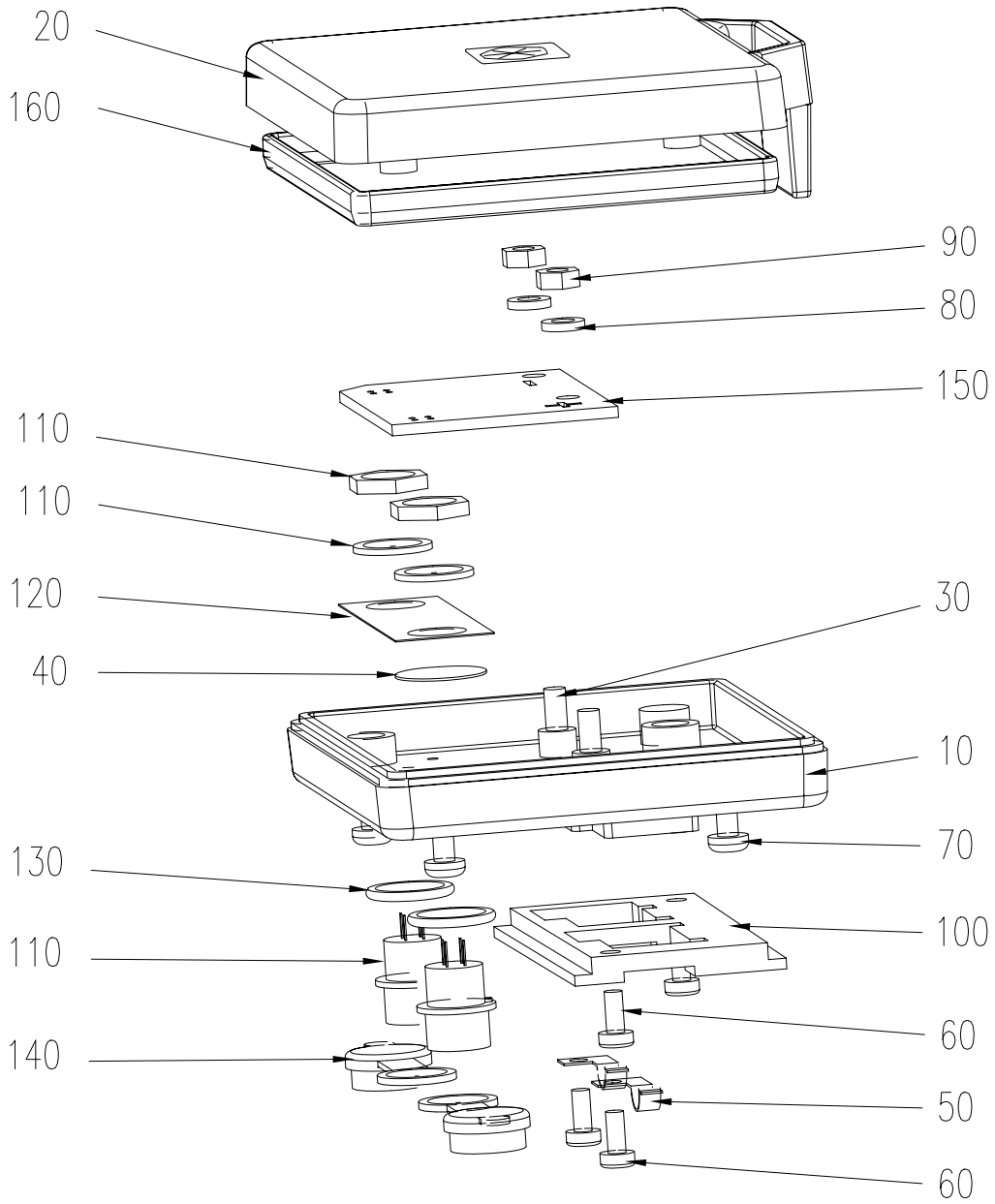

## Single adapter - 571 204 256

Pos.	Description	Part.no:	Pcs.
10	Base, single adapter	R71 204 218	1
20	Lid, single adapter	R71 204 219	1
40	Gore-tex valve	R71 908 466	1
50	Battery connector spring	R71 202 276	2
60	Screw, 2,5 x 6	571 903 074	4
70	Screw, 4 x 9,5	571 901 388	4
80	Locking washer	571 901 652	2
90	Nut, M3	941 680 310	2
100	Battery holder plate	R71 202 255	1
110	Hirose connector	R71 905 745	2
120	Hirose connector plate	N/A	1
130	O-ring, 9,1 x 1,6	R71 908 004	2
140	Rubber cover for Hirose connector	R71 202 203	2
150	BAB board	R71 205 280	1
160	Seal for single adapter lid	R71 204 255	1



## Power stick charger adapter - 571 126 301

fig 5-7



### Spare parts

There are no spare parts. The Power stick charger adapter is replaced as a complete unit.

## Chargers

### Super charger - 571 906 145

fig 5-8



Super charger - 571 906 145

Pos.	Description	Part.no:	Pcs.
10	Cable for charger (571 906 145) incl. cigarette connector	R71 127 300	1

There are no other spare parts. The Super charger is replaced as a complete unit.

### Single charger - 571 906 214

fig 5-9



Spare parts

There are no spare parts. The Single charger is replaced as a complete unit.

## Power supply - 571 906 146

fig 5-10



### Spare parts

There are no spare parts. The Power supply is replaced as a complete unit.

# Holders

## ACU Holder - 571 224 091

fig 5-11

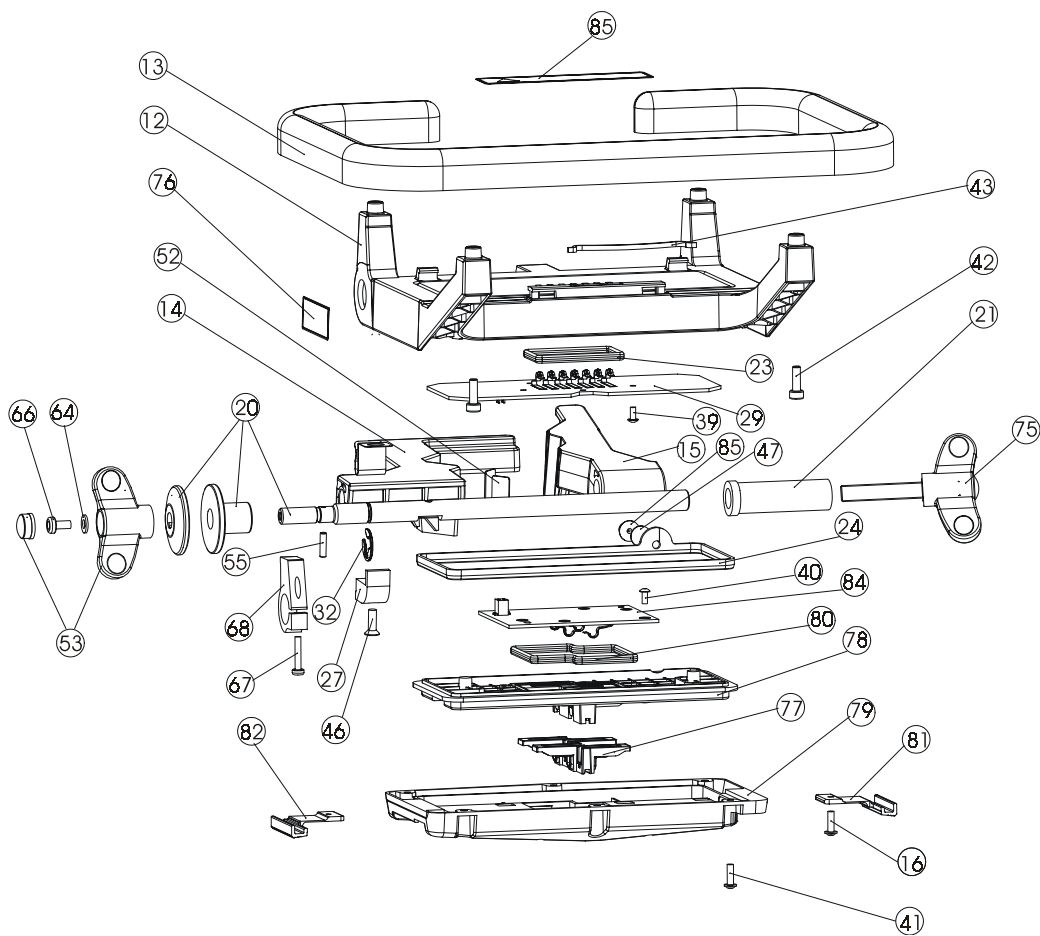

Pos.	Description	Part.no:	Pcs.
12	Chassis	R71 224 062	1
13	Support handle	R71 224 063	1
14	Pole lock, left	R71 224 087	1
15	Pole lock, right	R71 224 065	1
16	Screw, 30x10	R71 908 993	2
20	Axle incl. locking washer and locking sleeve	R71 224 640	1
21	Locking tube	R71 224 643	1
23	Sealing for contact springs	R71 242 028	1
24	Sealing ACU holder	R71 224 075	1
29	CAP2 board	R71 224 320	1
27	Support lock for axle	R71 224 079	1
32	Locking washer for axle	R71 906 276	1
39	Screw, 25x6	R71 908 978	5
40	Screw, 25x6	R71 908 978	6
41	Screw, 30x10	R71 908 993	6
42	Screw, 4x12	R41 104 291	4
43	Attachment spring	R71 224 042	1
46	Screw, 4x12	R71 906 309	1
47	Gore-tex valve	R71 908 466	1
52	Rubber tape	R71 224 059	2
53	Knob, left side	R71 906 275	1
55	Locking pin	R71 906 315	1
64	Washer, 4,3x9x0,8	R71 908 463	1
66	Screw, 4x8	R71 906 312	1
67	Screw, 3x16	R71 906 311	1
68	Lock for sleeve	R71 224 074	1
75	Knob, right side complete	R71 906 306	1
76	Label	R71 242 297	N/A

Pos.	Description	Part.no:	Pcs.
77	Rubber gasket for battery	R71 224 080	1
78	Battery terminal	R71 224 088	1
79	Holder for twin battery	R71 224 089	1
80	Rubber gasket for BCB2	R71 224 090	1
81	Locking device, right	R71 224 092	1
82	Locking device, left	R71 224 093	1
83	Cable outlet plug	R71 224 095	1
84	BCB2 board	R71 224 120	1
85	Sticker ACU	R71 215 114	1

### CU holder - 571 224 061

fig 5-12

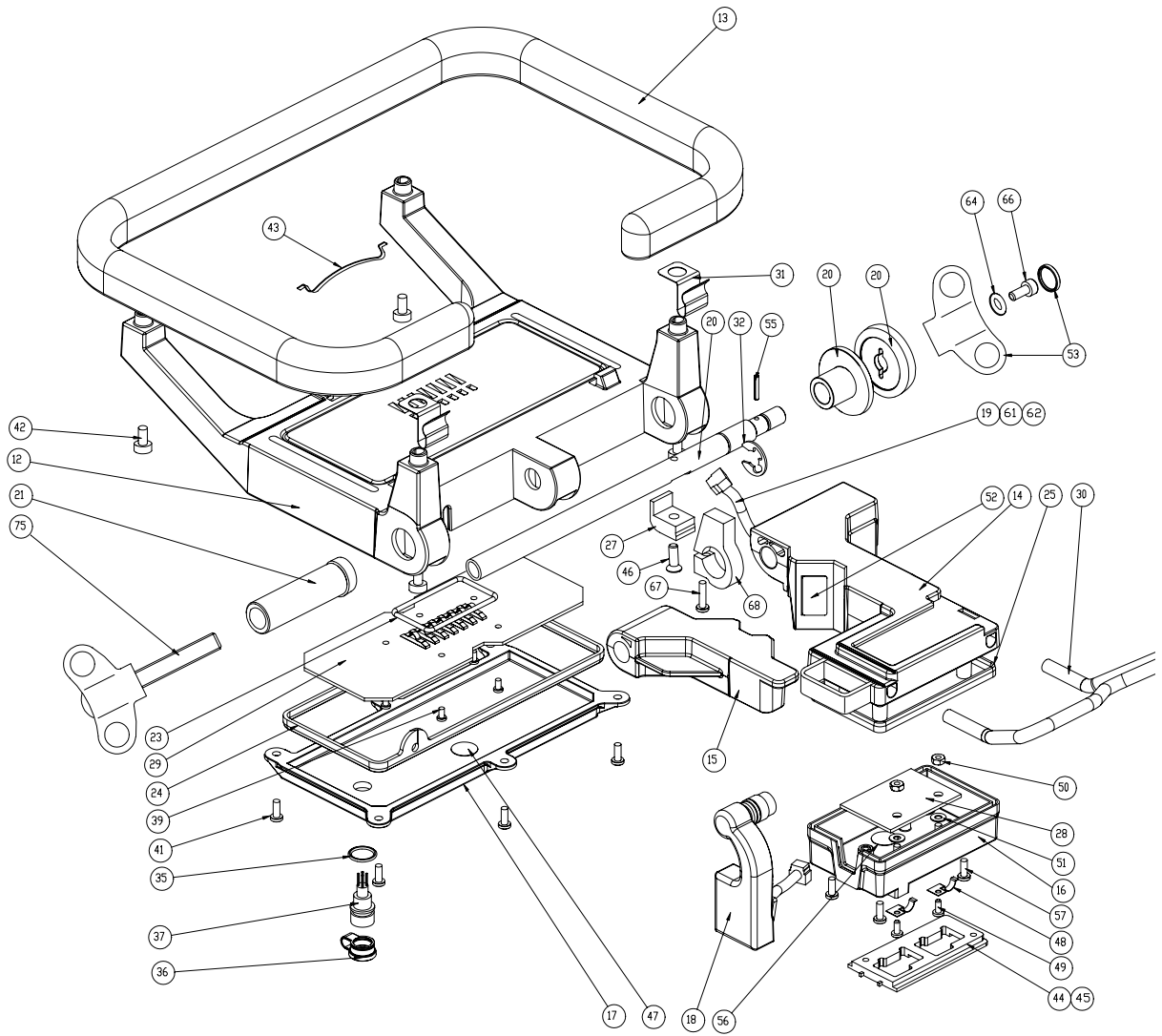

## CU holder - 571 224 061

Pos.	Description	Part.no:	Pcs.
12	Chassis	R71 224 062	1
13	Support handle	R71 224 063	1
14	Radio holder	R71 224 064	1
15	Pole lock	R71 224 065	1
16	Battery holder	R71 224 066	1
17	Lid for CAP board	R71 224 067	1
18	Radio connector	R71 224 068	1
19	Cable COP board - TBD board	R71 207 227	1
20	Axle incl. locking washer and locking sleeve	R71 224 640	1
21	Locking tube	R71 224 643	1
23	Sealing for contact springs	R71 242 028	1
24	Sealing CAP board	R71 224 075	1
25	Sealing battery holder	R71 224 076	1
27	Support lock for axle	R71 224 079	1
28	TBD board	R71 225 280	1
29	CAP board	R71 205 220	1
30	Support	R71 224 644	1
31	Pen holder	R71 224 081	2
32	Locking washer for axle	R71 906 276	1
35	O-ring, 9,1x1,6	R71 908 004	1
36	Cover for Hirose connector	R71 202 203	1
37	Hirose connector	R71 222 024	1
39	Screw, 25x6	R71 908 978	5
41	Screw, 30x10	R71 908 993	6
42	Screw, 4x12	R41 104 291	4
43	Attachment spring	R71 224 042	1
44	Bracket for battery	R71 202 255	1



## CU holder - 571 224 061

Pos.	Description	Part.no:	Pcs.
45	Screw, 3x10	R71 906 313	2
46	Screw, 4x12	R71 906 309	1
47	Gore-tex valve	R71 908 466	1
48	Contact spring, battery	R71 202 276	2
49	Screw, 2,5x6	R71 903 074	2
50	Nut, M3	R71 908 890	2
51	Locking washer, 3,2	R71 906 314	2
52	Rubber tape	R71 224 059	2
53	Knob, left side	R71 906 275	1
55	Locking pin	R71 906 310	1
57	Screw, 30x10	R71 908 993	4
61	Holder for cable	R86 003 102	1
62	Screw	R71 908 993	1
67	Screw, 3x16	R71 906 311	1
68	Lock for axle	R71 224 074	1
75	Knob, right side complete	R71 906 306	1

Holder for CU & radio - 571 224 030

Holder for CU & radio/RS232 - 571 204 242

fig 5-13

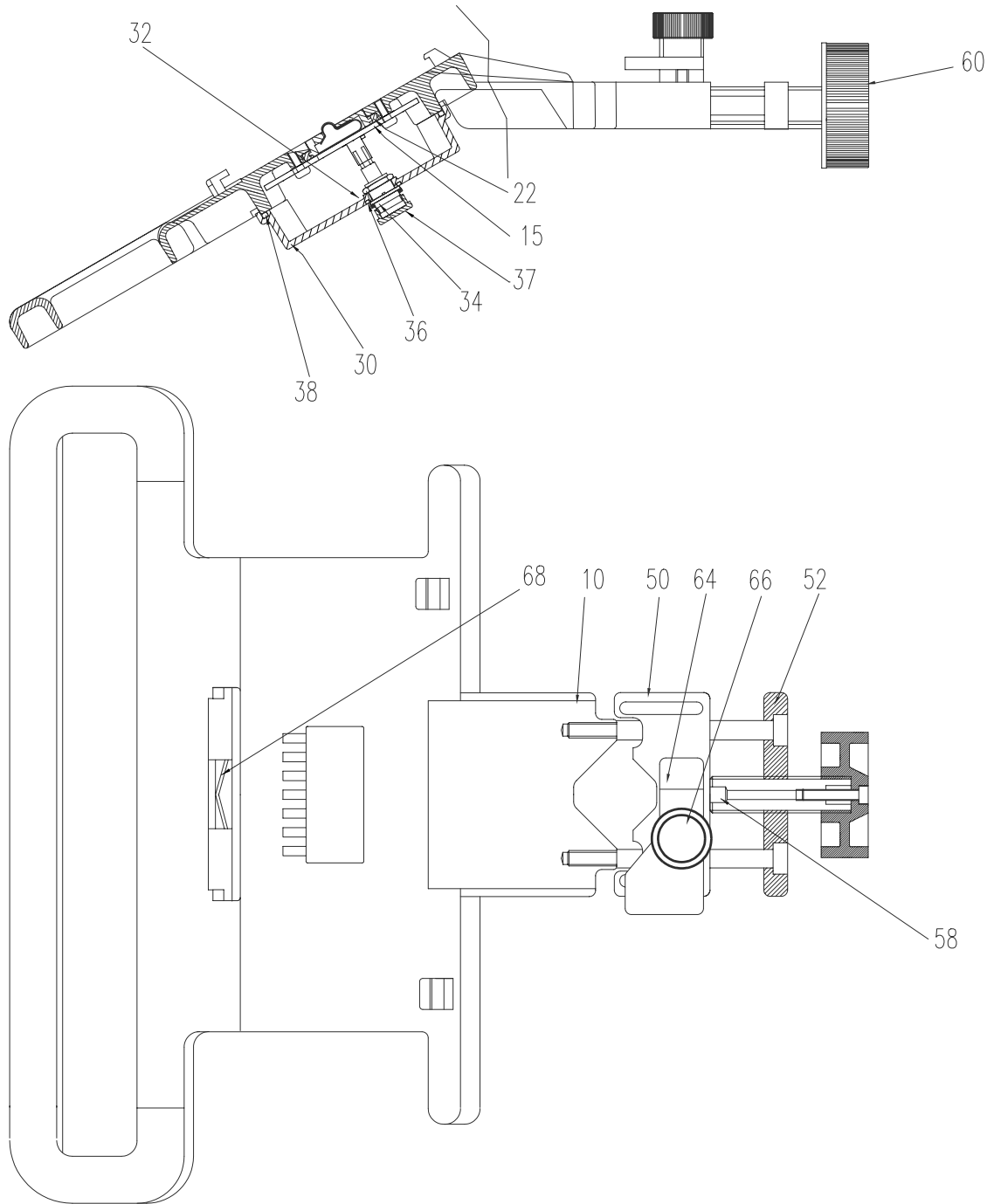

Holder for CU & radio - 571 224 030  
Holder for CU & radio/RS232 - 571 204 242

Pos.	Description	Part.no:	Pcs.
10	Chassis holder, only for 571 204 242	R71 224 053	1
15	Board CAP, only for 571 204 242	R71 205 220	1
22	Shield spring, only for 571 204 242	R71 202 038	1
30	Back cover, holder, only for 571 204 242	R71 204 231	1
32	Ventilator, only for 571 204 242	R71 908 466	1
34	Connector Hirose, only for 571 204 242	R71 222 024	2
36	O-Ring 9,1*1,6, package, only for 571 204 242	R71 908 004	2
37	Cover Hirose connectors, package, only for 571 204 242	R71 202 203	2
38	O-Ring 132*2,0, only for 571 204 242	R71 908 847	1
50	Bracket	R71 181 505	1
52	Bracket	R71 181 506	1
58	Back stop	R71 212 075	1
60	Locking knob	R71 126 106	1
64	Clamp	R71 202 374	1
66	Adjustment control	R71 908 076	1
68	Attach. spring CU600, package	R71 224 042	1

### Holder for battery - 571 204 300

fig 5-14

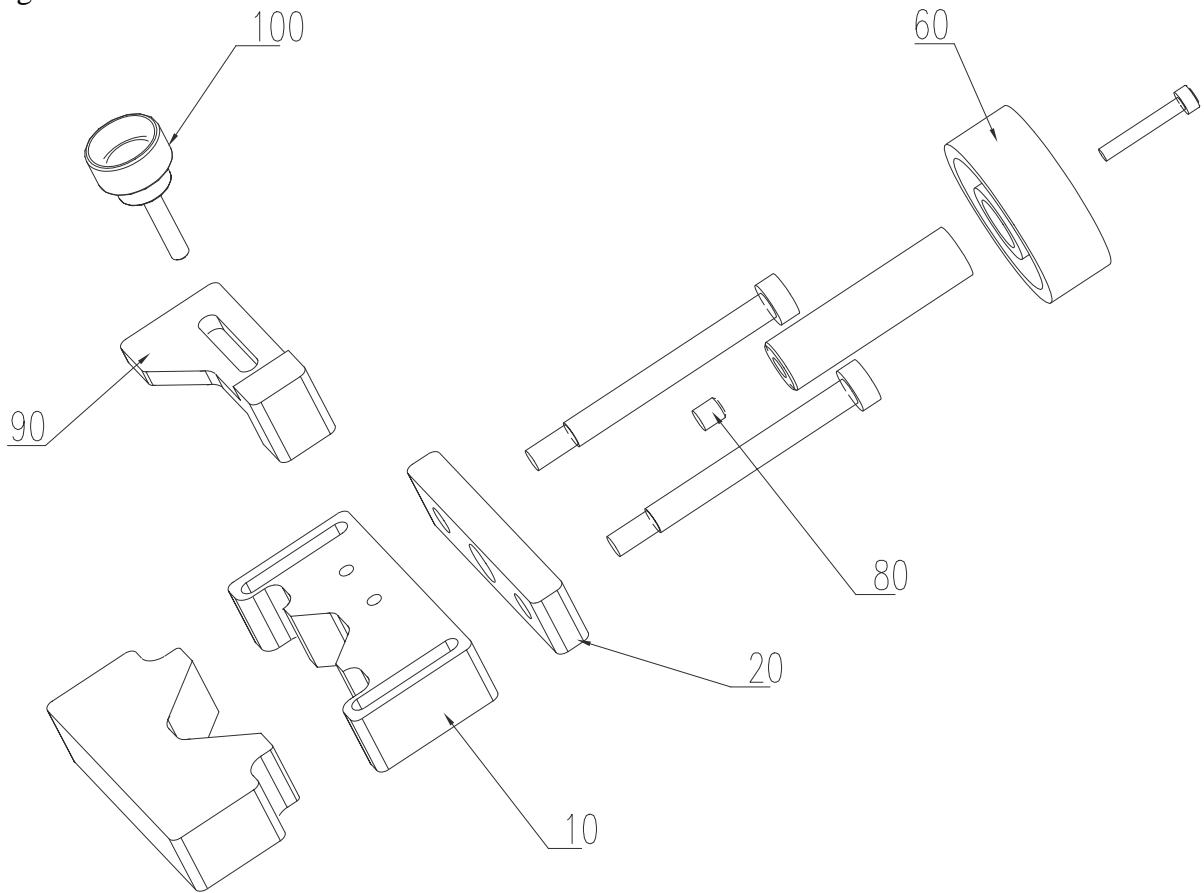

### Holder for battery - 571 204 300

Pos.	Description	Part.no:	Pcs.
10	Bracket	R71 181 505	1
20	Bracket	R71 181 506	1
60	Locking knob	R71 126 106	1
80	Back stop	R71 212 075	1
90	Clamp	R71 202 374	1
100	Adjustment control	R71 908 076	1

## Holder for ACU - 571 212 080

fig 5-15

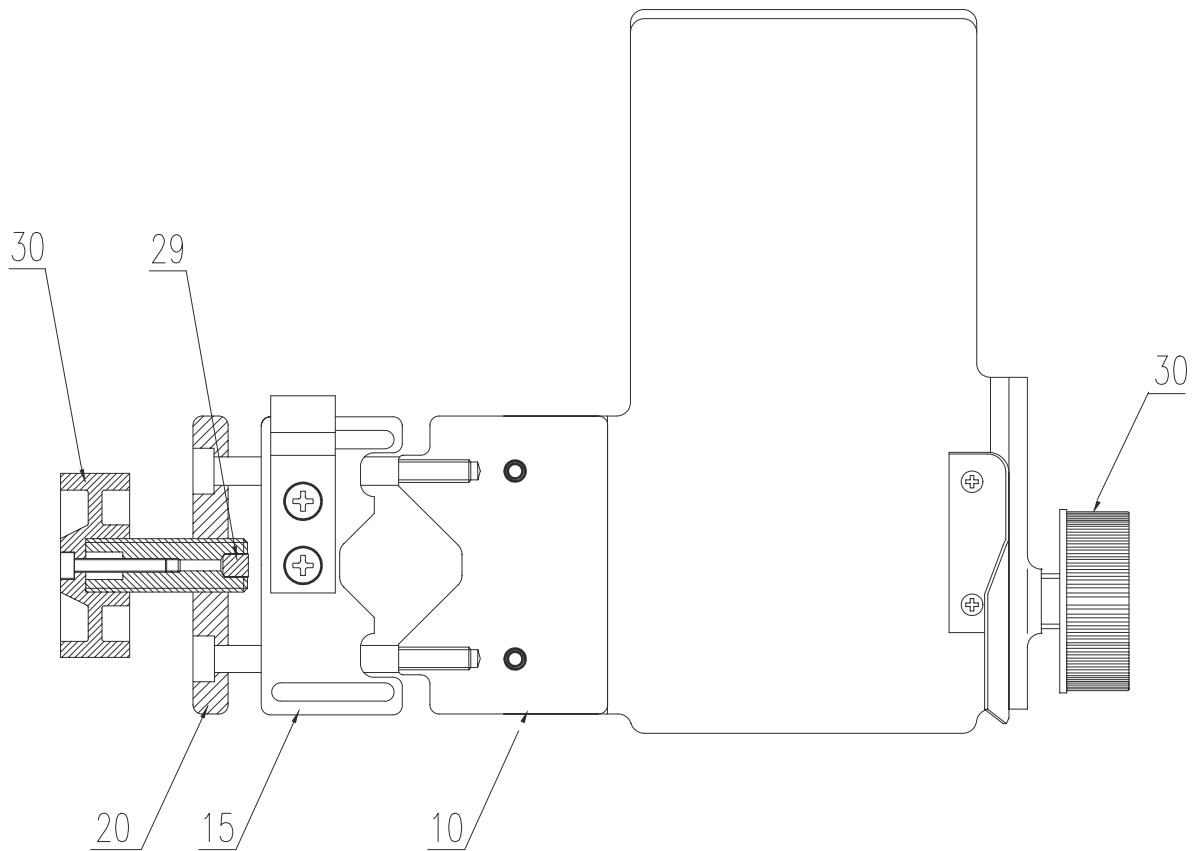

## Holder for ACU - 571 212 080

Pos.	Description	Part.no:	Pcs.
10	Rod fastening for panel holder	R71 181 504	1
15	Bracket	R71 181 505	1
20	Bracket	R71 181 506	1
29	Back stop	R71 212 075	1
30	Locking knob	R71 126 106	1

## The Walker - 571 126 297

fig 5-16



### Spare parts

There are no spare parts. The Walker is replaced as a complete unit.

# RMT

RMT 4000 - 571 181 380

RMT 4000LR - 571 181 778

fig 5-17

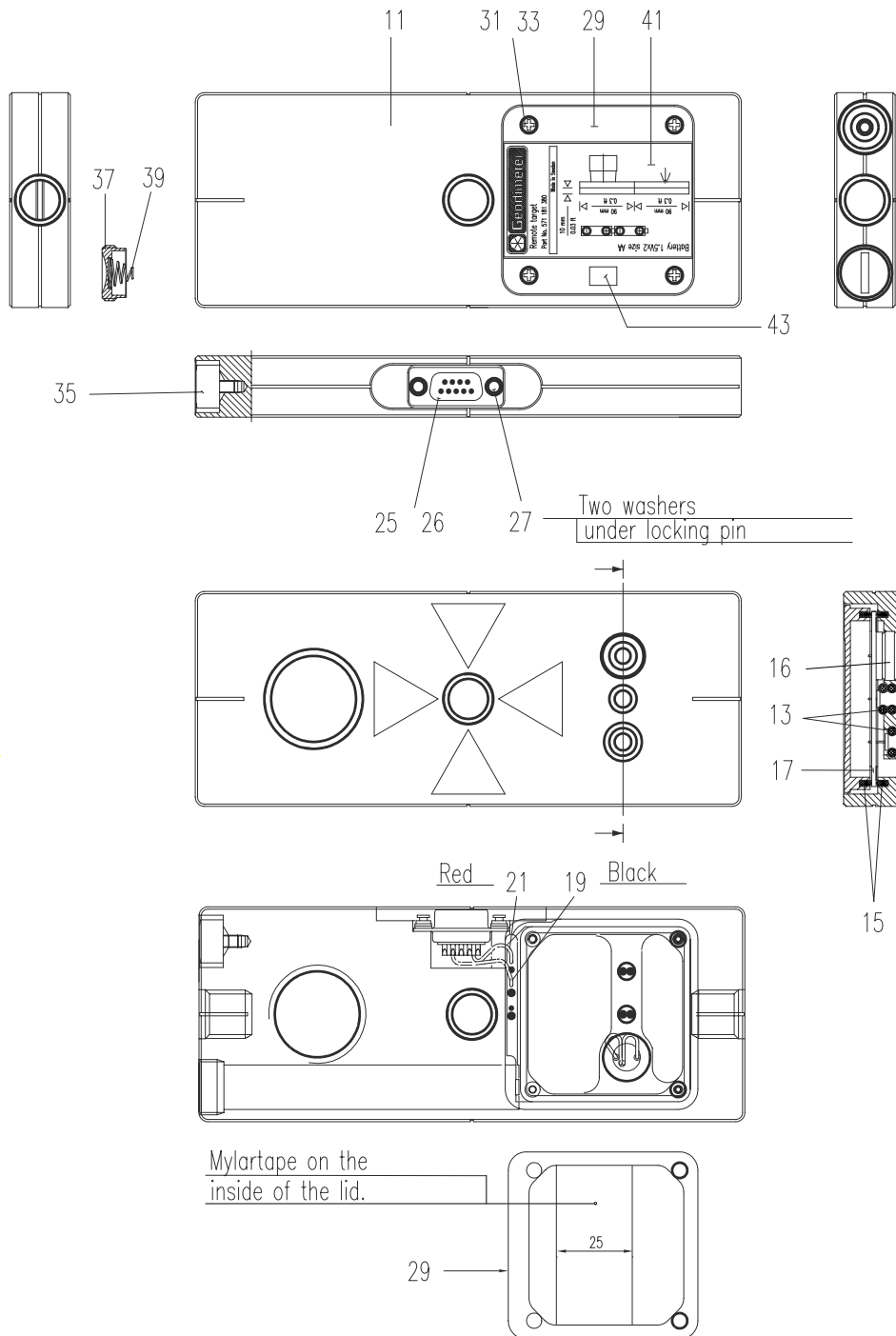

RMT 4000 - 571 181 380  
RMT 4000LR - 571 181 778

Pos.	Description	Part number	Pcs.
11	Chassis	R71 181 382	1
13	Sealing (Signal diodes)	R71 905 839	3
15	Sealing	R71 180 056	1
16	Rubber for on/off switch (10 p)	R71 143 043	1
17	Board RMT (for standard version)	R71 181 400	1
17	Board RMLR (for long range version)	R71 182 380	1
19	Cable black	N/A	1
21	Cable red	N/A	1
25	Connector D-Sub	571 903 671	1
26	Cover D-Sub	571 905 847	1
27	Locking pin	N/A	2
29	Lid	R71 181 383	1
31	Sealing O-Ring 2*1 (20 p)	R71 905 215	1
33	Screw 2,5*12	571 905 234	4
35	Level	N/A	1
37	Lid for battery	R71 181 384	1
39	Pressure spring for battery	R71 905 794	1
41	Label	N/A	1
43	CE Label	N/A	1



RMT 600 - 571 202 220

RMT 600LR - 571 202 480

fig 5-18

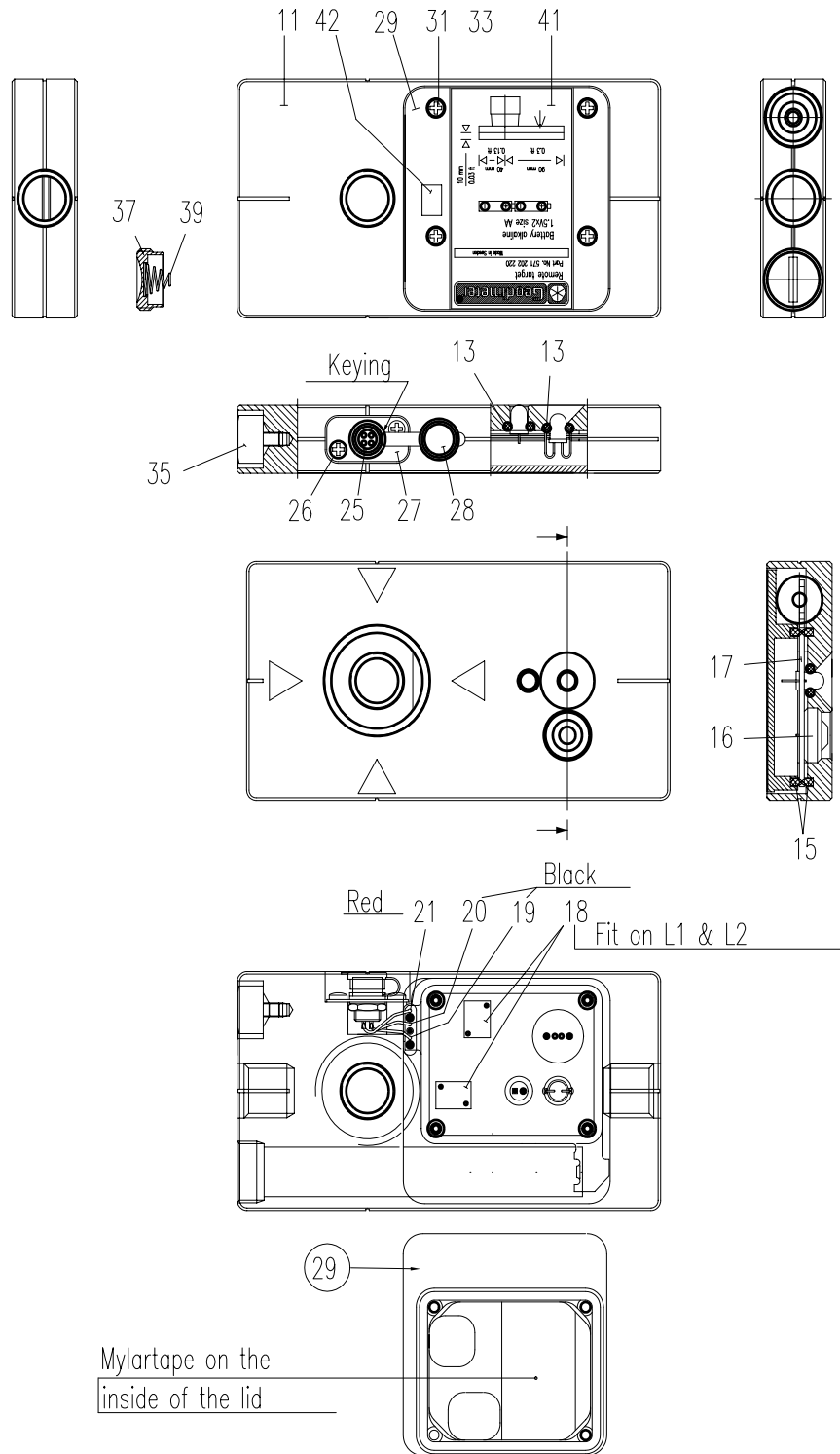

RMT 600 - 571 202 220  
RMT 600LR - 571 220 480

Pos.	Description	Part.no:	Pcs.
11	Chassis	R71 202 222	1
13	Sealing 4.3*2.4 (signal diodes)	R71 905 839	2
15	Sealing	R71 202 230	2
16	Rubber for on/off switch (10 p)	R71 143 043	1
17	Board RTG (for standard version)	R71 203 600	1
17	Board RTL (for long range version)	R71 209 200	1
18	Tape	571 908 059	3
19	Cable black	N/A	1
20	Cable black	N/A	1
21	Cable red	N/A	1
25	Connector Hirose 4pin	R71 905 988	1
26	Screw 2,5*6	571 903 074	2
27	Cover	R71 202 228	1
28	Cover Hirose connector	R71 202 203	1
29	Lid	R71 202 223	1
31	Sealing 2,0*1,0	R71 905 215	4
33	Screw 2,5*12	571 905 234	4
35	Level	R71 905 814	1
37	Lid for battery	R71 181 384	1
39	Pressure spring for battery	R71 905 794	1
41	Label	N/A	1
42	CE Label	N/A	1
70	Board ESF	R71 181 780	1

# RMT SLR - 571 204 360

fig 5-19

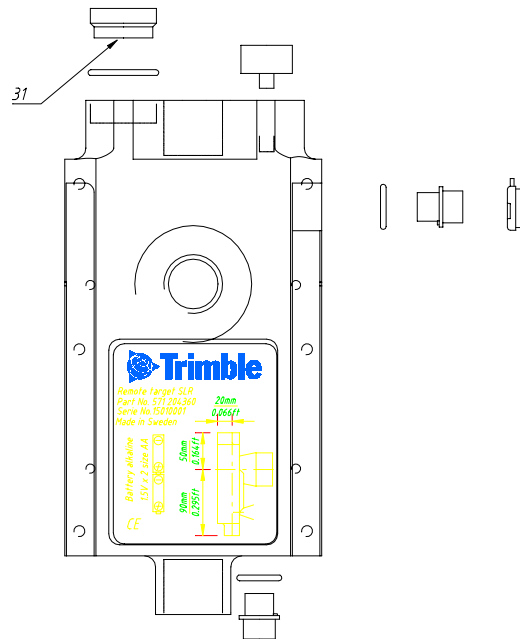
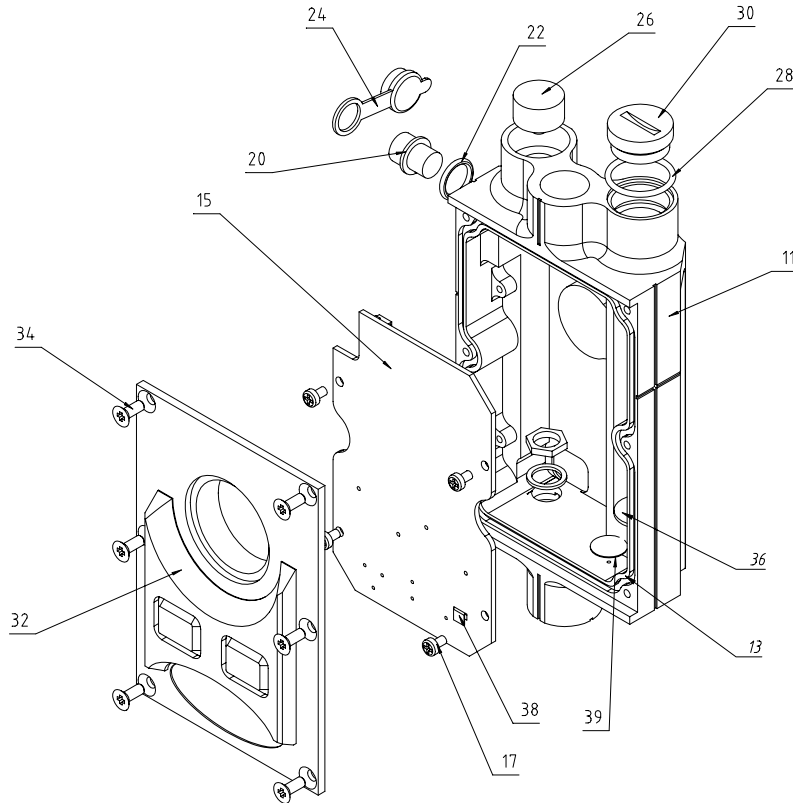

## RMT SLR - 571 204 360

Pos.	Description	Part.no:	Pcs.
13	Sealing	R71 204 362	1
15	Board RMTSL	R71 205 560	1
17	Screw, 2,5x4	571 905 597	4
20	Cable, 4x70	R71 207 126	2
22	O-Ring, 9,1x1,6	R71 908 004	2
24	Cover for Hirose connector	R71 202 203	2
26	Level	R71 905 814	1
28	O-Ring, 16,1x1,6	R71 908 866	1
30	Battery lid	R71 181 384	1
31	Pressure spring for battery	R71 905 794	1
32	Lid complete	R71 204 363	1
34	Screw, 3x8	571 905 226	6
36	Insulator	R71 204 367	1
38	Battery contact for board RMTSL	R71 204 368	1
39	Gore-tex valve	R71 908 466	1
48	Switch	R71 906 251	2

Tracker Target ATS - 571 181 874

Tracker Target 600 - 571 181 774

fig 5-20

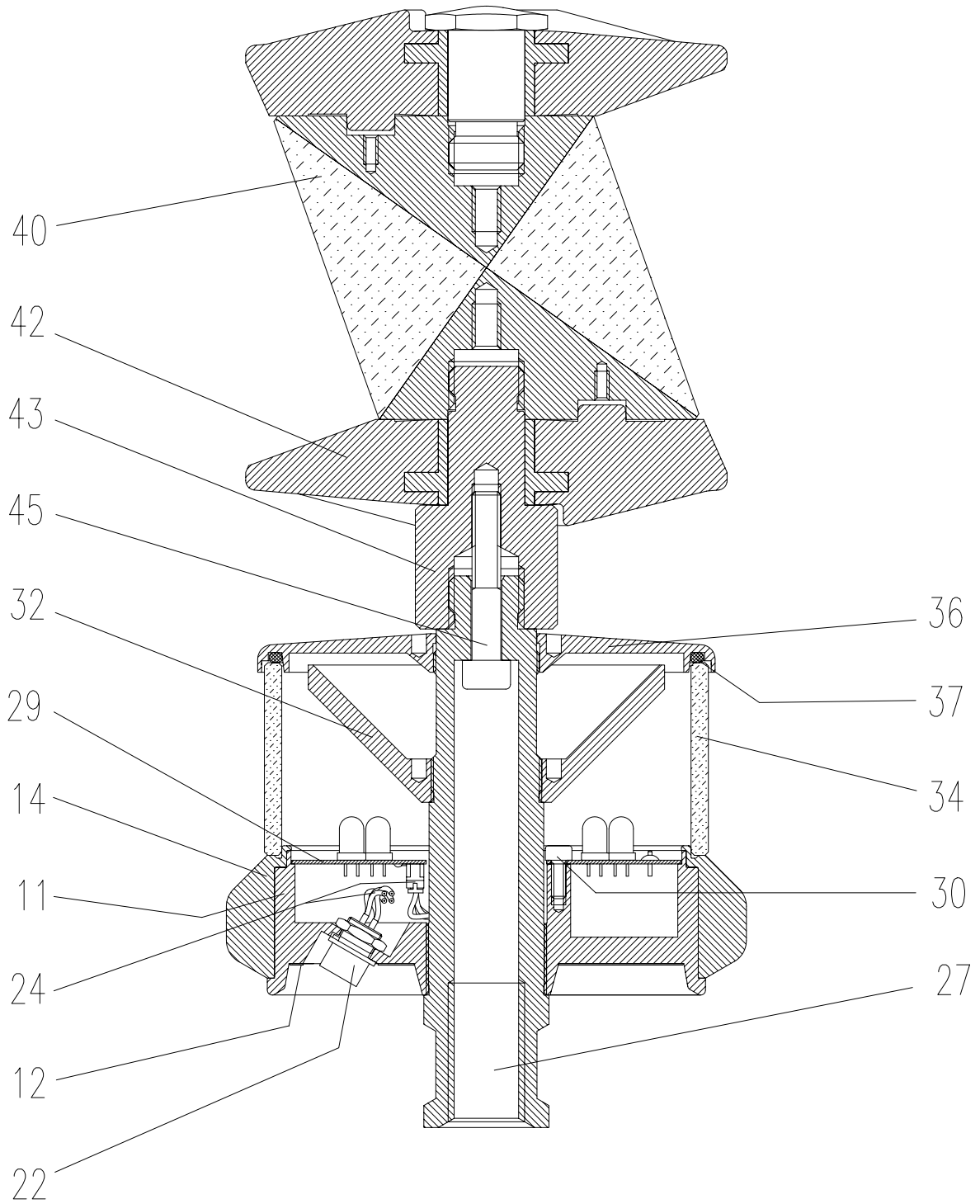

Tracker target ATS - 571 181 874  
Tracker target 600 - 571 181 774

Pos.	Description	Part.no:	Pcs.
11	Chassis	N/A	1
12	Label Remote target	N/A	1
14	Protection ring	N/A	1
22	Connector Hirose female	R71 905 988	1
24	Cable 4*70	R71 207 124	1
27	Axel	N/A	1
29	Board RFC*	R71 181 960	1
30	Screw 3*6	941 104 220	3
32	Mirror	R71 181 880	1
34	Window	R71 181 881	1
36	Lid	R71 181 882	1
37	Sealing 85*2,5 (10p)	R71 908 350	1
40	Octa prism replaced by Prism ring	571 233 023	1
42	Octa prism protection	N/A	1
43	Prism distance for Prism ring (571 233 023)	R71 233 041	1
45	Screw 6*35	571 908 351	1

\* The RFC board can be replaced with the RFCM board part.no: R71 235 960. The RFCM board must be correctly configured and the cable from the connector must be changed, see Electrical description RFCM Board configuration.

RMT Super - 571 181 870

fig 5-21

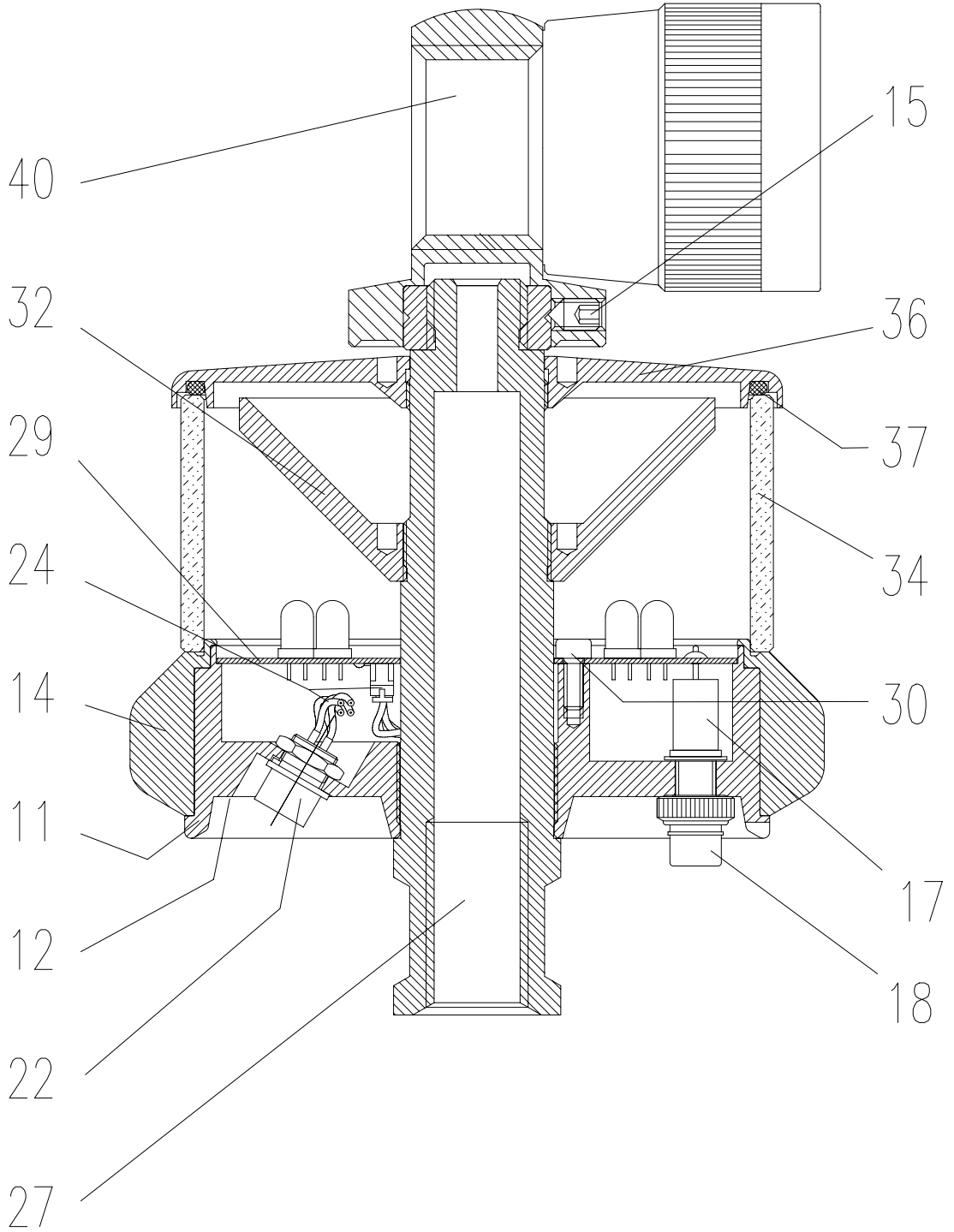

## RMT Super - 571 181 870

Pos.	Description	Part.no:	Pcs.
11	Chassis	N/A	1
12	Label remote target	N/A	1
14	Protection ring	R71 181 878	1
15	Screw 5*8	571 908 356	3
17	Switch 2-way	R71 908 375	4
18	Rubber cover	R71 908 376	4
22	Connector Hirose	R71 905 988	1
24	Cable 4*70	R71 207 124	1
27	Axel	N/A	1
29	Board RFC	R71 181 960	1
30	Screw 3*6	941 104 220	3
32	Mirror	R71 181 880	1
34	Window	R71 181 881	1
36	Lid	R71 181 882	1
37	Sealing 85*2,5	R71 908 350	1
40	Prism holder	R71 181 434	1



RMT600 ATS (Hirose) - 571 233 020

fig 5-22

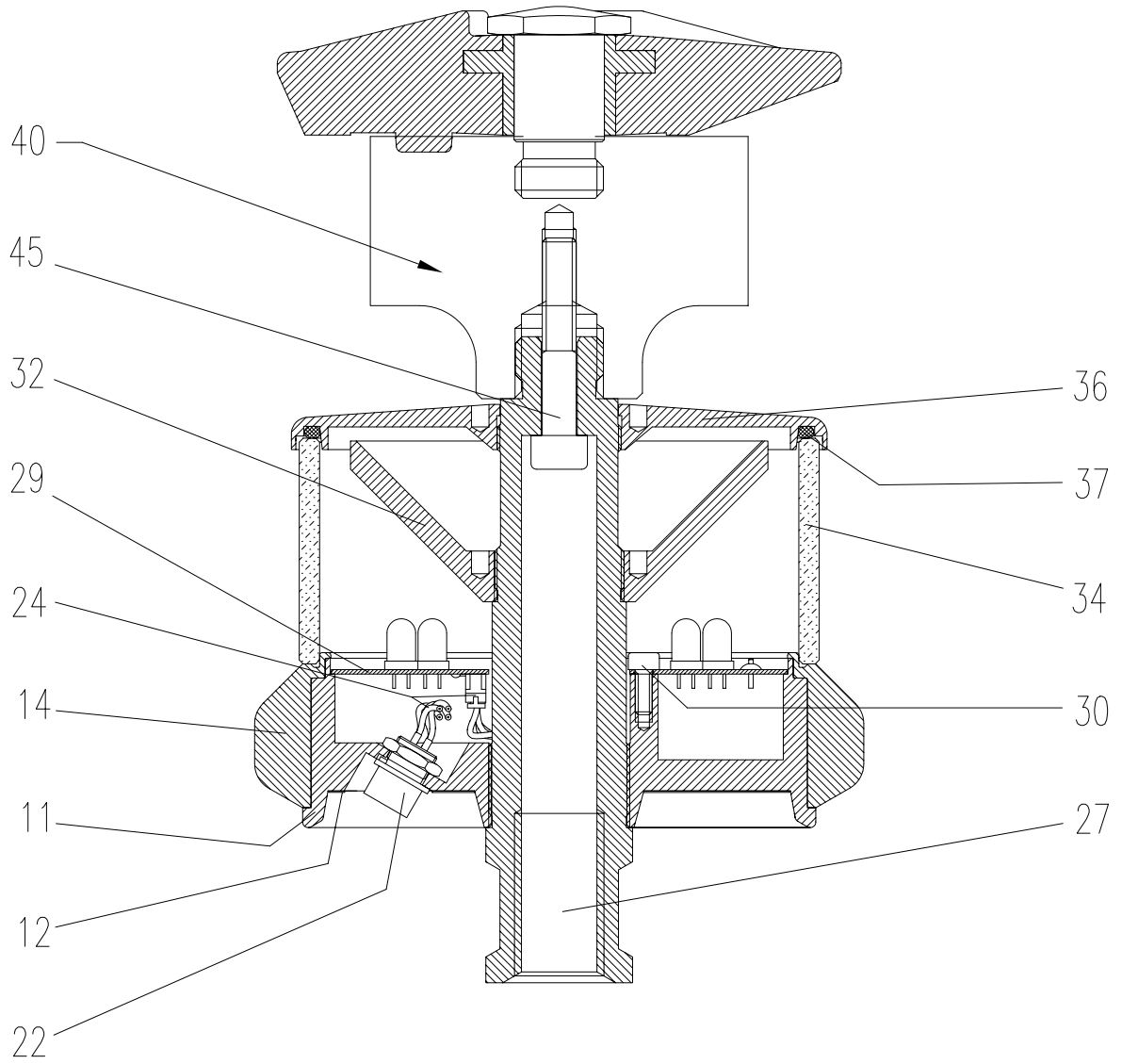

## RMT 600 ATS (Hirose) - 571 233 020

Pos.	Description	Part.no:	Pcs.
11	Chassis	N/A	1
12	Label	N/A	1
14	Protection ring	R71 181 878	1
22	Connector Hirose female	R71 905 988	1
24	Cable 4x70, Hirose connector - RFC board	R71 207 124	1
27	Centre shaft	N/A	1
29	Board RFC*	R71 181 960	1
30	Screw, 3x6	941 104 220	3
32	Mirror conical	R71 181 880	1
34	Window	R71 181 881	1
36	Cover	R71 181 882	1
37	O-Ring 85x2,5 (delivered in a set of 10 pieces)	R71 908 350	1
40	Prism ring	571 233 023	1
45	Screw, 6x35	571 908 351	1

\* The RFC board can be replaced with the RFCM board part.no: R71 235 960. The RFCM board must be correctly configured and the cable from the connector must be changed, see Electrical description RFCM Board configuration.

RMT 600 ATS (Canon) - 571 233 025

RMT Tracker Target Plus - 571 181 586

fig 5-23

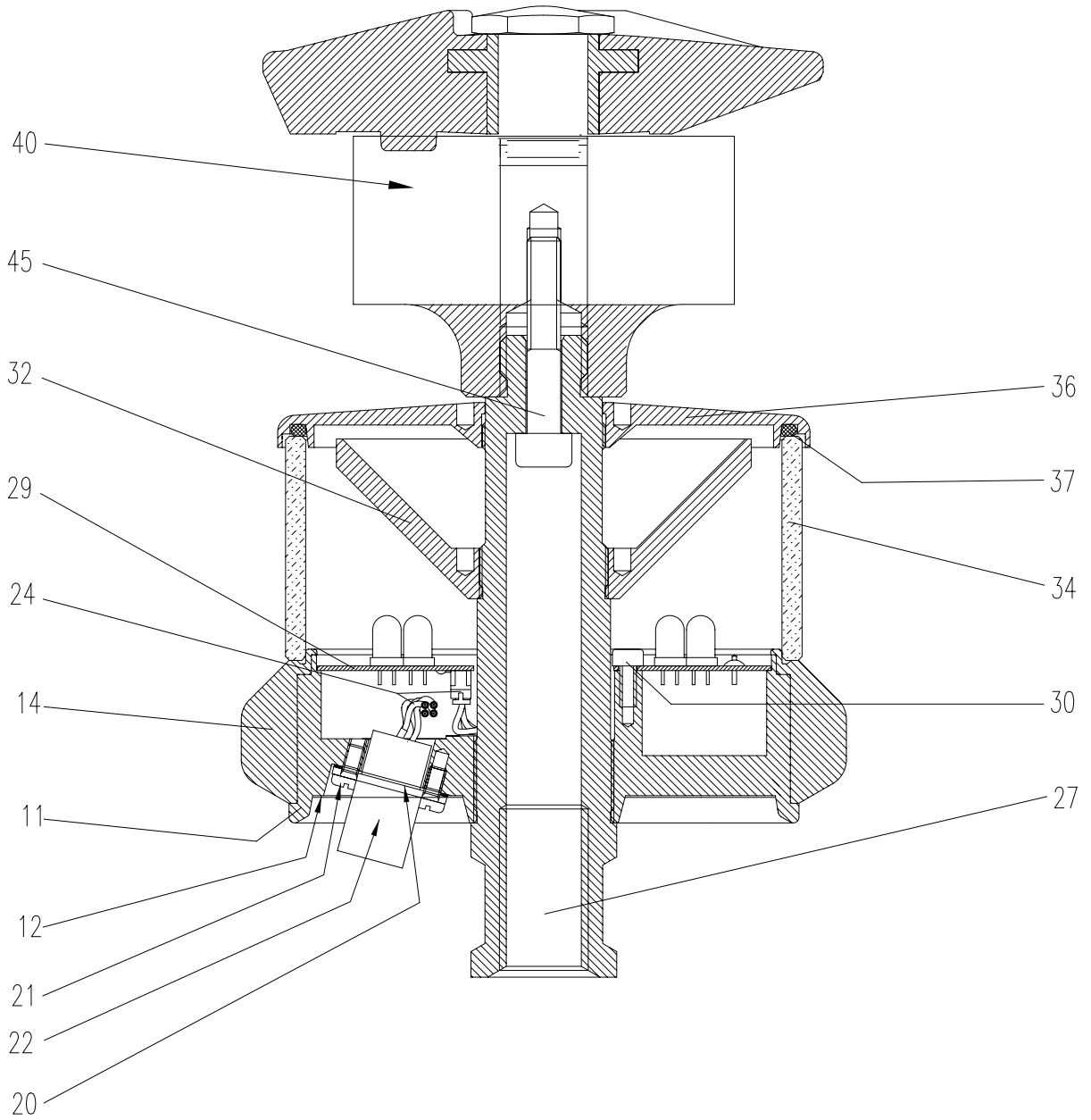

RMT 600 ATS (Canon) - 571 233 025  
RMT Tracker target Plus - 571 181 586

Pos.	Description	Part.no:	Pcs.
11	Chassis	N/A	1
12	Label	N/A	1
14	Protection ring	R71 181 878	1
20	Sealing connector (Canon)	R71 908 509	1
21	Screw, 3x6	571 903 430	4
22	Connector Canon 4-p	R71 908 507	1
24	Cable 4x70, Canon connector - RFC board	R71 207 124	1
27	Centre shaft	N/A	1
29	Board RFC*	R71 181 960	1
30	Screw, 3x6	941 104 220	3
32	Mirror conical	R71 181 880	1
34	Window	R71 181 881	1
36	Cover	R71 181 882	1
37	O-Ring 85x2,5 (delivered in a set of 10 pieces)	R71 908 350	1
40	Prism ring (571 233 025)	571 233 023	1
40	Octa prism	571 181 586	1
	Octa prism protection	571 181 586	1
45	Screw, 6x35	571 908 351	1

\* The RFC board can be replaced with the RFCM board part.no: R71 235 960. The RFCM board must be correctly configured and the cable from the connector must be changed, see Electrical description RFCM Board configuration.

### RMT 600 ATS multi channel - 571 233 035

fig 5-24

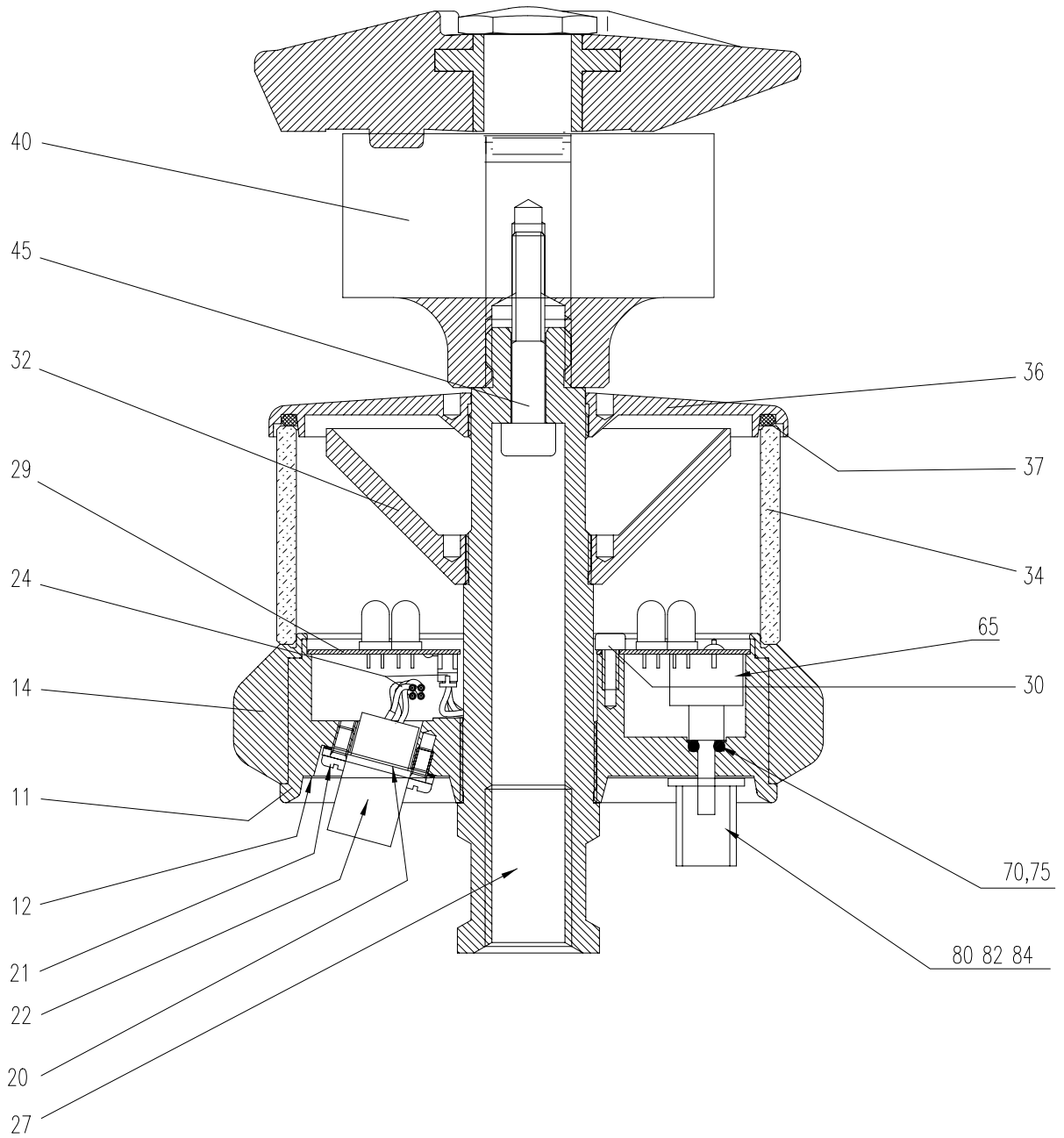

## RMT 600 ATS multi channel - 571 233 035

Pos.	Description	Part.no:	Pcs.
11	Chassis	N/A	1
12	Label	N/A	1
14	Protection ring	R71 181 878	1
20	Sealing connector (Canon)	R71 908 509	1
21	Screw, 3x6	571 903 430	4
22	Connector Canon 4-p	R71 908 507	1
24	Cable 4x70, Canon connector - RFC board	R71 207 124	1
27	Centre shaft	N/A	1
29	Board RFCM	R71 235 960	1
30	Screw, 3x6	941 104 220	3
32	Mirror conical	R71 181 880	1
34	Window	R71 181 881	1
36	Cover	R71 181 882	1
37	O-Ring, 85x2,5 (delivered in a set of 10 pieces)	R71 908 350	1
40	Prism ring	571 233 023	1
45	Screw, 6x35	571 908 351	1
65	Frequency switch	R71 906 263	1
70	O-ring, 2,9x1,78	R71 901 892	1
75	Nylon washer	571 901 748	1
80	Frequency Knob	R71 908 980	1
82	Nut cover - knob	R71 908 981	1
84	Lid for knob	R71 908 982	1
	Gore-tex valve	R71 908 466	1

### Prism ring - 571 233 023

fig 5-25

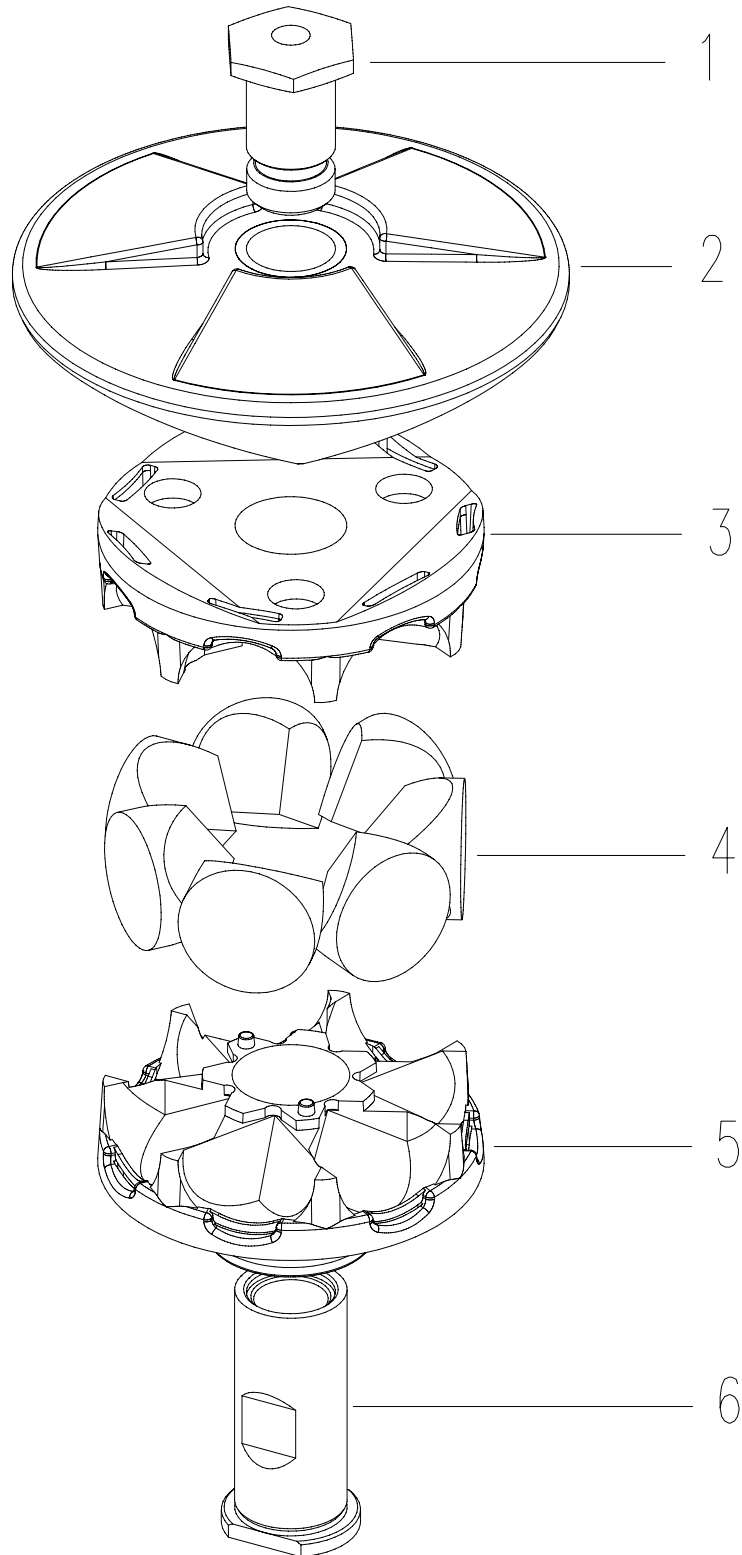

## Prism ring - 571 233 023

Pos.	Description	Part.no:	Pcs.
1	Screw*	R71 181 899	1
2	Rubber protection	R71 181 898	7
3	Prism holder, upper*	R71 233 028	1
4	Prism	R71 204 314	1
5	Prism holder, lower*	R71 233 022	1
6	Spacer	R71 233 029	1

\* On early versions of the prism ring these three parts are different from the present version. To be sure of compatibility, even if only one part must be changed, change all three parts.



### RMT 600 TS - 571 204 240

fig 5-26

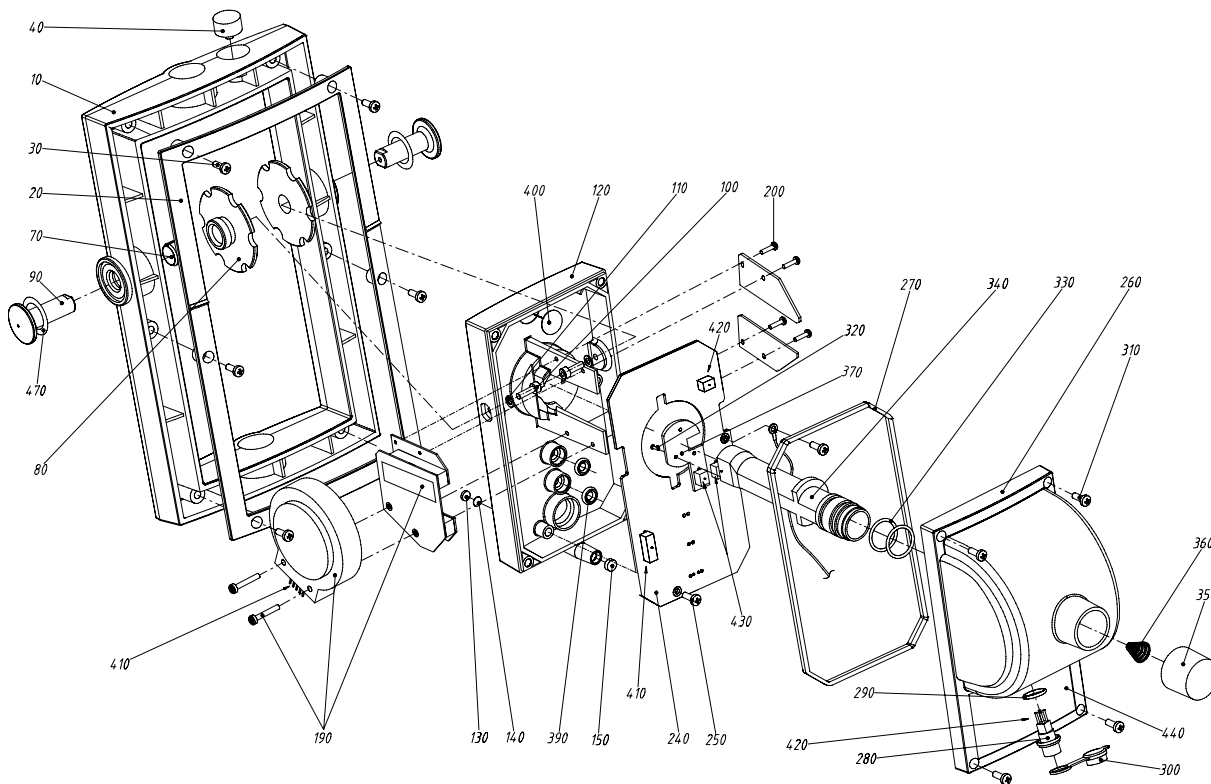

### RMT 600 TS - 571 204 240

Pos.	Description	Part.no:	Pcs.
10	Frame	R71 204 234	1
20	Frame cover	R71 204 235	1
30	Screw, 3x8	571 903 480	6
40	Level	R71 905 814	1
70	Sleeve bearing	R71 204 275	2
80	Lock screw	R71 204 276	2
90	Axis	R71 204 277	2
100	Screw, 3x8	941 104 222	2
110	Washer, 3,2x6	944 482 124	2
120	Cover front yoke	R71 204 232	1

## RMT 600 TS - 571 204 240

Pos.	Description	Part.no:	Pcs.
130	Front glass, coarse sight (included in pos. 120)	N/A	1
140	Visual reference, coarse sight (included in pos. 120)	N/A	1
150	Lens, coarse sight (included in pos. 120)	N/A	1
160	Attachment for damper, upper	N/A	1
165	Attachment for damper, lower	N/A	1
170	Damper for angle unit	N/A	2
180	Attachment for angle unit	N/A	1
190	Angle unit	R71 908 833	1
200	Screw, 2x6	571 908 129	4
220	Screw, 2,5x16	N/A	2
225	Double sided tape	N/A	
240	Board FRT	R71 205 240	1
250	Screw, 2,5x6	571 903 074	2
260	Cover back yoke	R71 204 233	1
270	Seal yoke	R71 204 241	1
280	Hirose connector	R71 222 024	1
290	O-ring	R71 908 004	1
300	Cover for Hirose connector	R71 202 203	1
310	Screw, 2,5x6	571 903 074	4
320	Screw 1,2*5 (included in pos. 370)	N/A	3
330	O-ring 16,1*1,6 battery holder	R71 908 866	2
340	Battery holder	R71 204 295	1
350	End cap for battery holder	R71 204 238	1
360	Spring in Cap	R71 905 794	1
370	Board BBR2 (battery holder board)	R71 205 400	1
390	O-ring 4,2*2,4 diodes	R71 905 839	2
400	Ventilator	R71 908 466	1

## RMT 600 TS - 571 204 240

Pos.	Description	Part.no:	Pcs.
410	Cable10*90	R71 207 202	1
420	Cable 4*90	R71 207 203	1
430	Cable 4*90	R71 207 204	1
435	Cable GND	N/A	
440	Label	R71 204 286	1
470	Shims 21,5/14,0/0,3	571 204 296	2

RMT 604 - 571 204 310 / RMT 606 - 571 204 610

fig 5-27

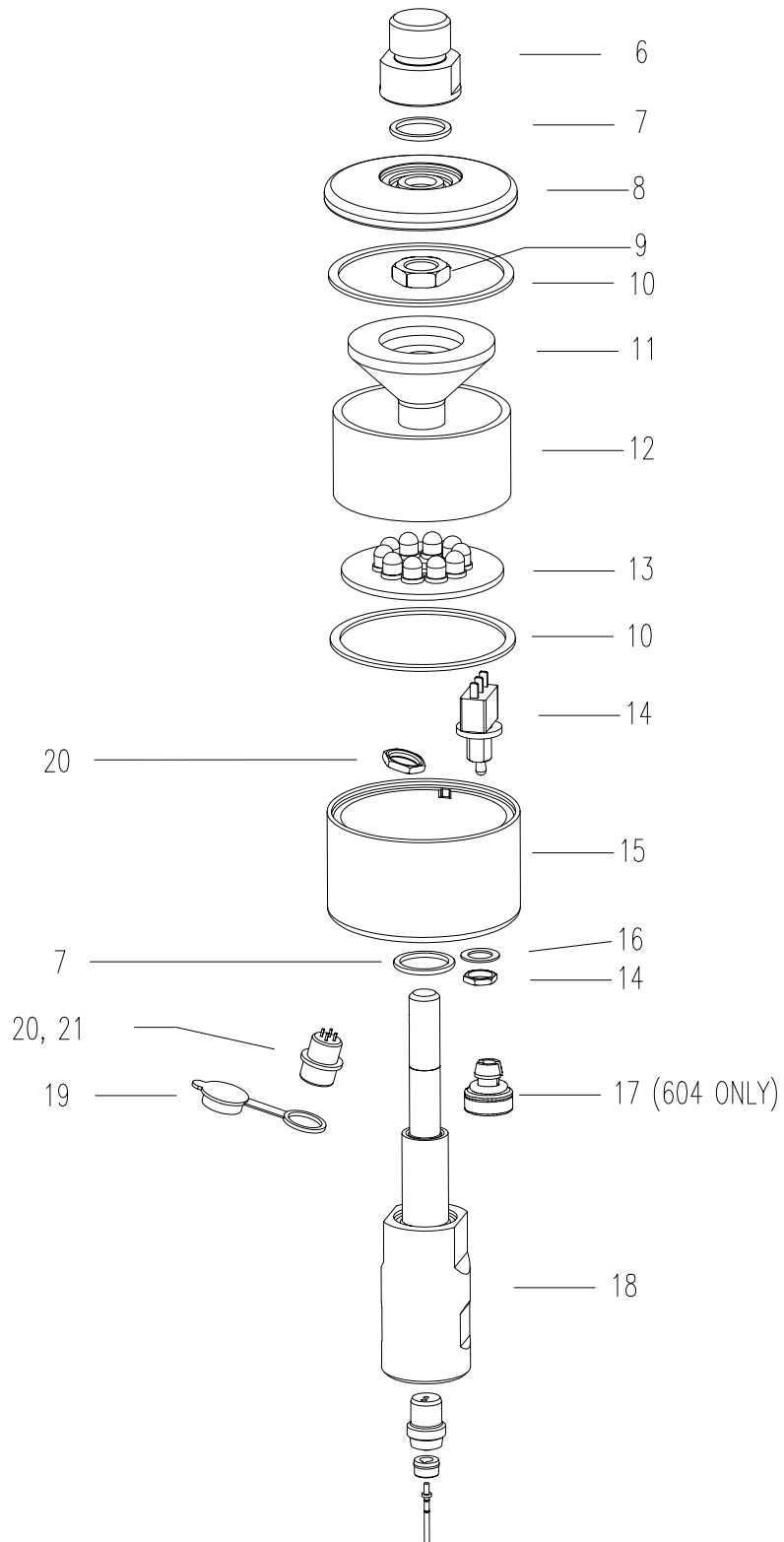

RMT 604 - 571 204 310  
RMT 606 - 571 204 610

Pos.	Description	Part.no:	Pcs.
6	Shaft locking nut	R71 204 506	1
7	Shaft sealing ring	R71 204 505	2
8	Lid	R71 204 510	1
9	Reflector locking nut	571 905 040	1
10	Glass sealing ring	R71 204 511	2
11	Reflector	R71 204 507	1
12	Glass	R71 204 509	1
13	Board, MOD	R71 205 540	1
14	Switch, on/off incl. nut	R71 204 515	1
15	Base RMT 604	R71 204 504	1
15	Base RMT 606	R71 204 514	1
16	Washer for on/off switch		1
17	Gore-tex valve (RMT 604 ONLY)	R71 204 512	1
18	Centre shaft, RMT 604	R71 204 508	1
18	Centre shaft, RMT 606	R71 204 513	1
19	Cover for Hirose connector	R71 202 203	1
20	Hirose connector incl. locking washer and nut	R71 905 988	1
21	Hirose connector incl. cable to MOD board	R71 207 126	1

### Prism ring - 571 204 312

fig 5-28

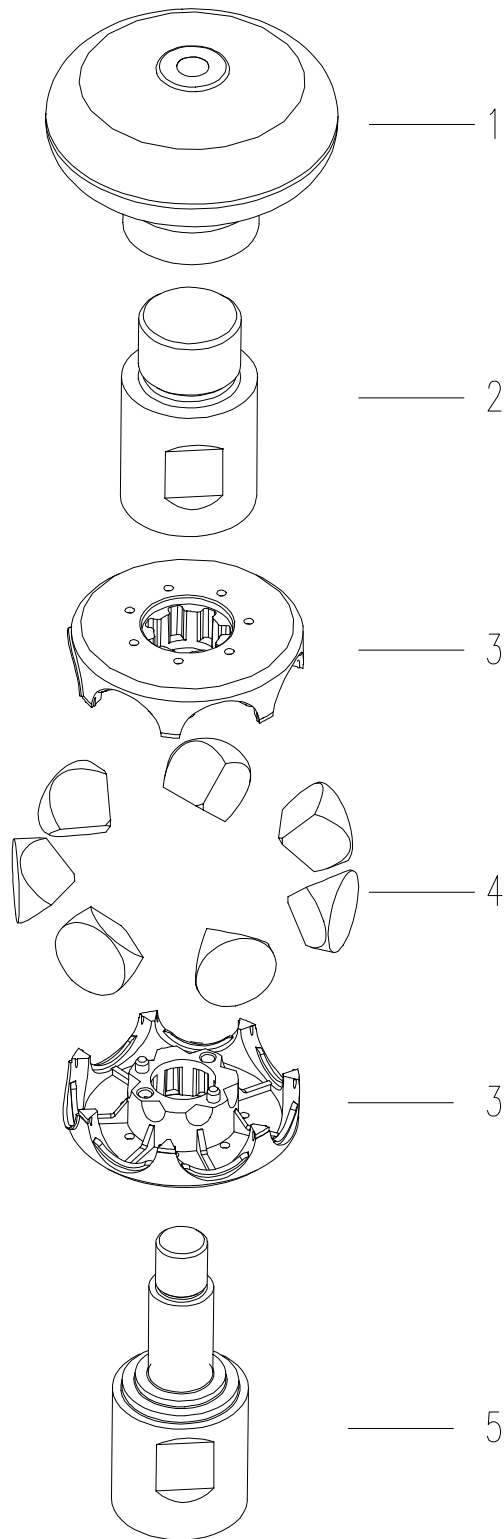

## RMT 604 / 606 Prism ring - 571 204 312

Pos.	Description	Part.no:	Pcs.
1	Handle incl. bubble	R71 204 500	1
2	Upper spacer	R71 204 501	1
3	Prism holder	R71 204 503	2
4	Prism	R71 204 248	7
5	Lower spacer	R71 204 502	1

# Rods

## Telescopic rod - 571 126 088

fig 5-29

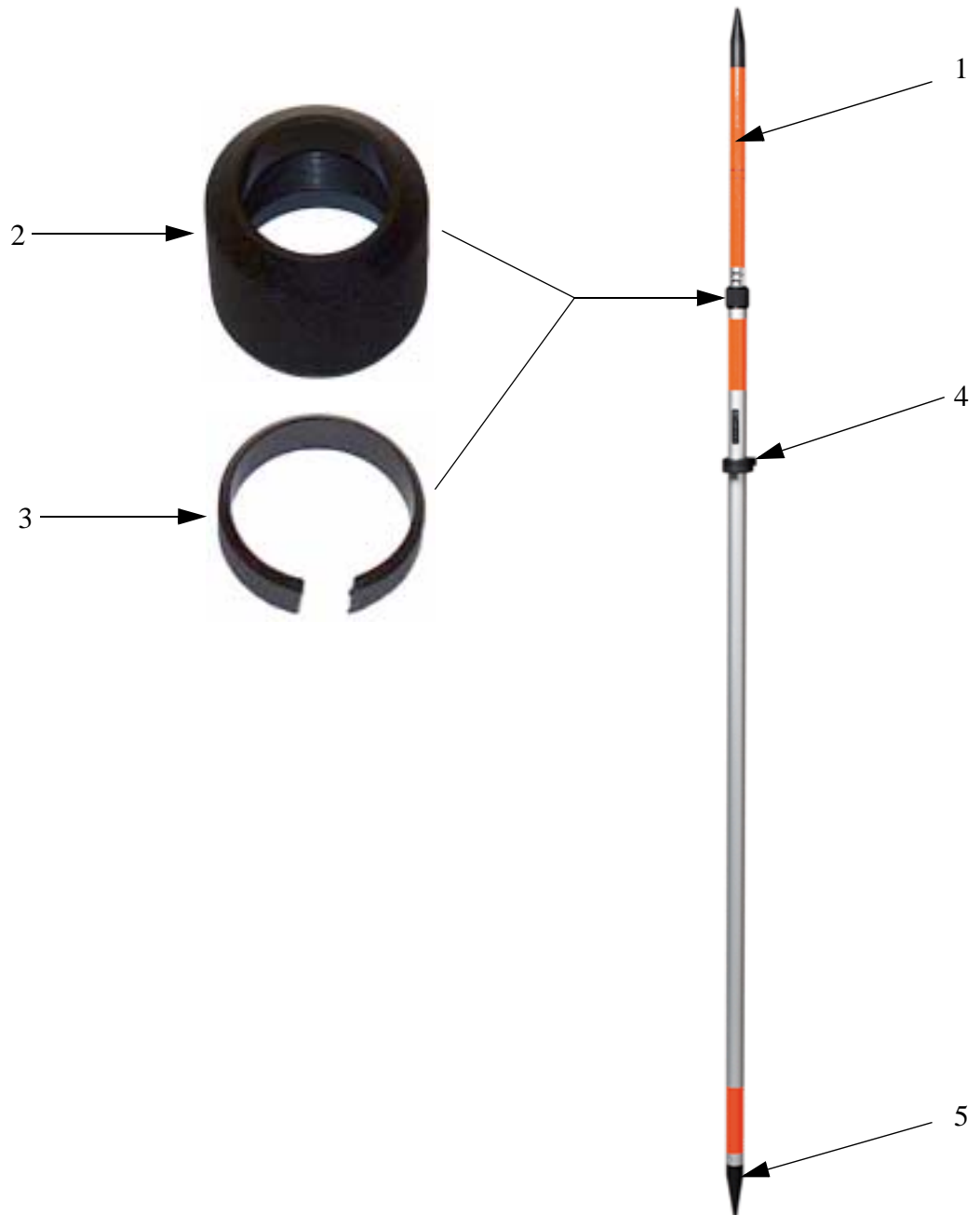



## Telescopic rod - 571 126 088

Pos.	Description	Part.no:	Pcs.
1	Signal pin	R71 126 256	1
2	Locking sleeve for rod (also for 571 126 078)	R71 127 308	1
3	Locking ring for rod (also for 571 126 078)	R71 127 306	1
4	Level (also for 571 126 078)	R71 126 257	1
5	Point (also for 571 126 078)	R71 126 253	1

## Telescopic rod - 571 126 098

fig 5-30

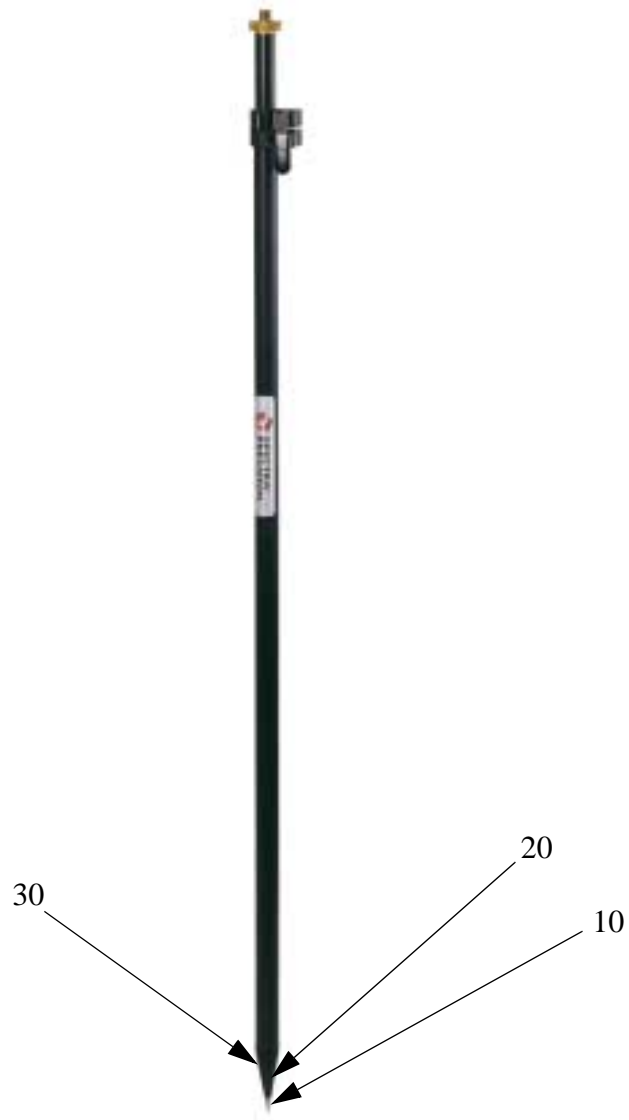

### Spare part list

Pos.	Description	Part.no:	Pcs.
10	Tip	R71 126 292	1
20	Point	R71 127 309	1
30	Threaded insert	R71 127 310	1

# Telescopic rod - 571 181 090

fig 5-31

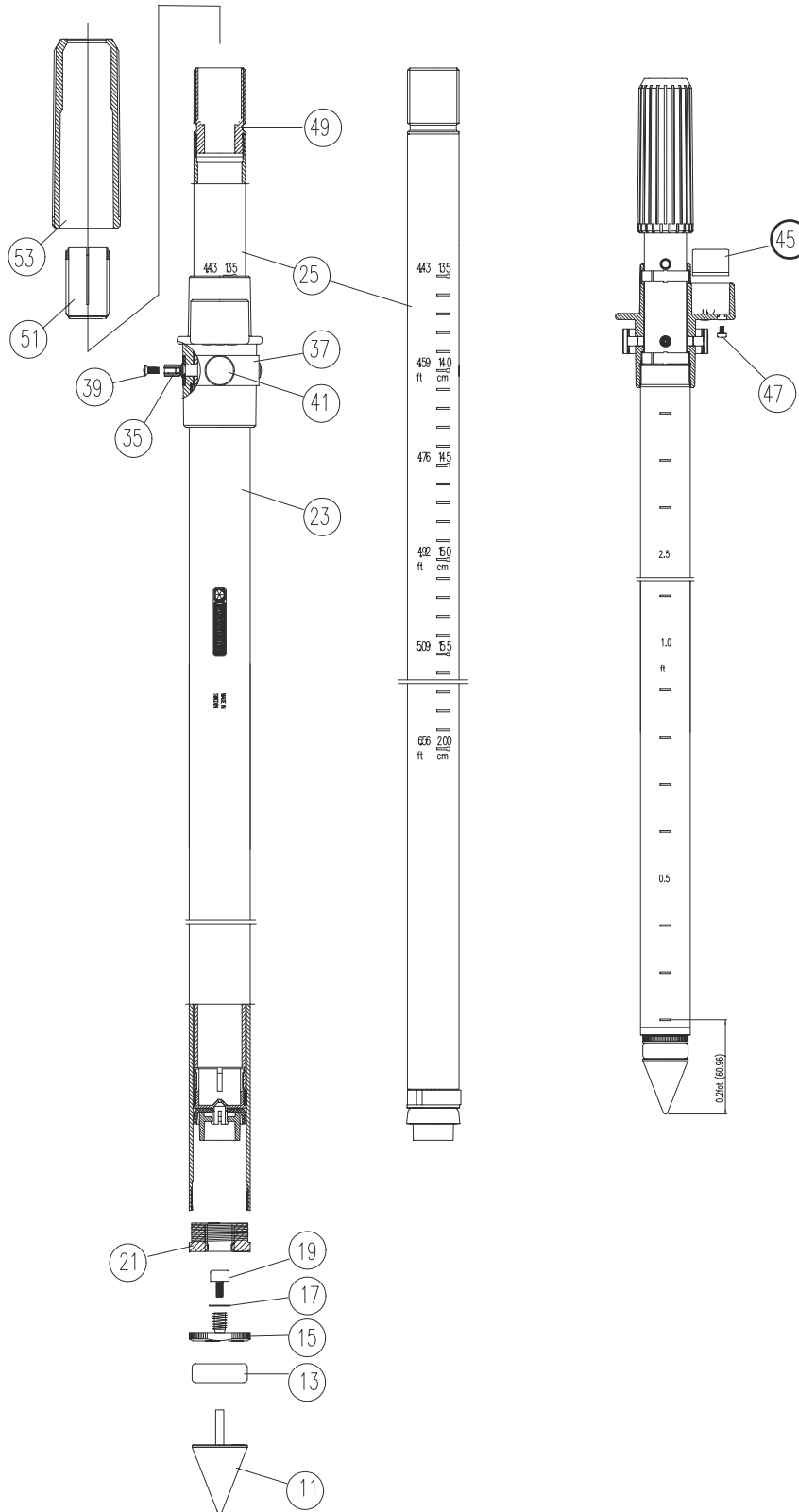

## Telescopic rod - 571 181 090

Pos.	Description	Part.no:	Pcs.
11	Point	R71 181 089	1
13	Shock absorber	R71 181 088	1
15	Fastening 5/8"	571 181 082	1
17	Washer 6,4*12	944 482 153	1
19	Screw 6*8	571 905 591	1
21	Sleeve	N/A	1
23	Exterior tube	N/A	1
25	Inner tube	N/A	1
35	Tap	N/A	1
37	Spring ring	R71 181 083	1
39	Screw 3*8	571 903 482	2
41	Button (10p)	R71 181 085	2
45	Level	R71 905 565	1
47	Screw 3*8	571 903 480	3
49	Gland nut	R71 181 096	1
51	Sleeve	R71 181 098	1
53	Handle	R71 181 097	1

# RPU

## RPU GDM 4000 &ATS

fig 5-32

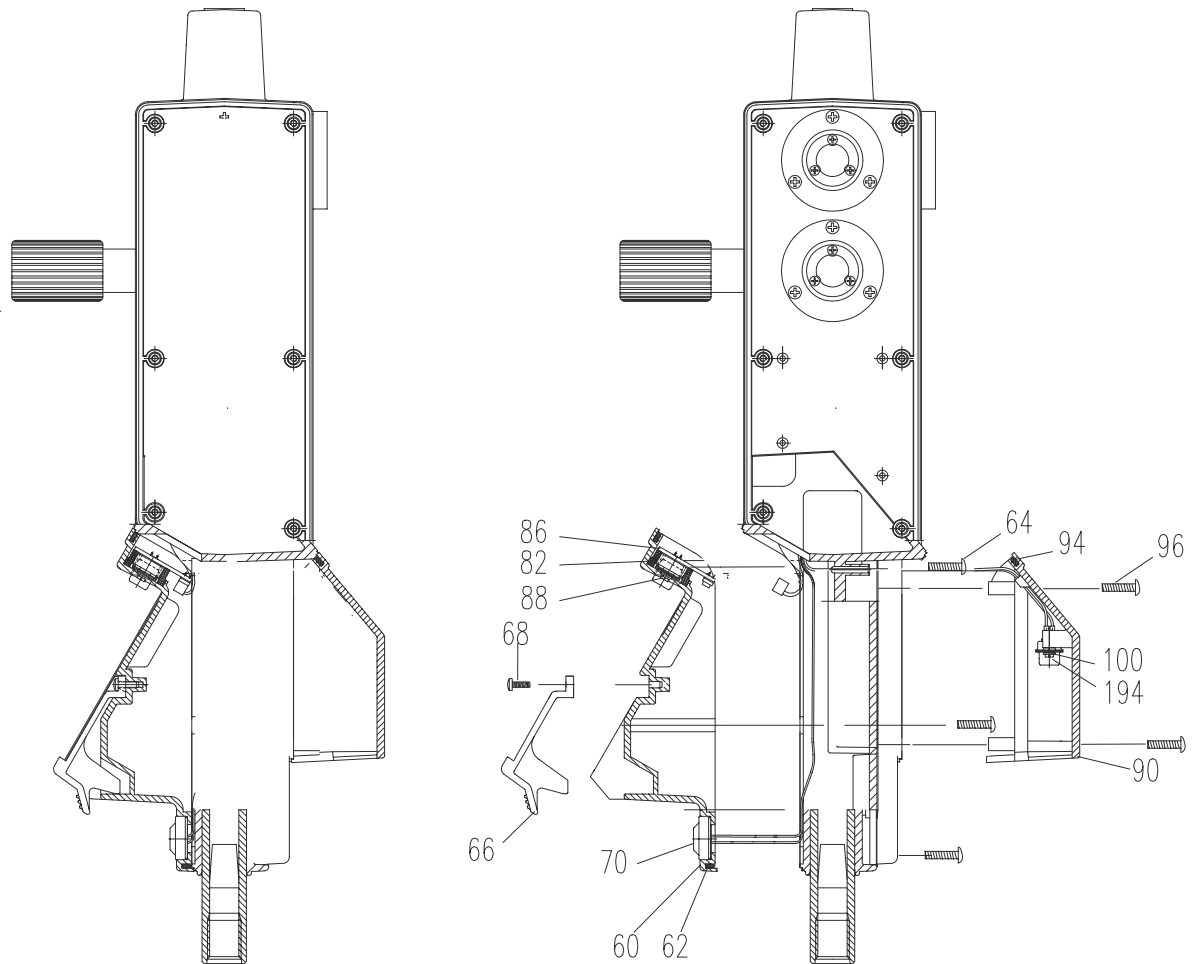

## RPU GDM 4000 &amp; ATS

Pos.	Description	Part.no:	Pcs.
60	CU Holder	571 180 406	1
62	Sealing (CU Holder)	571 180 471	1
64	Screw 4*25	571 903 403	6
66	Clip holder for CU	R71 180 402	1
68	Screw 4*13	571 903 078	2
70	Button SMR complete	R71 180 452	1
82	Sealing board CBO	571 180 470	1
86	Board CBO	R71 180 720	1
88	Screw 2*8	941 134 166	2
90	Battery cover	R71 180 405	1
94	Sealing for Battery cover	R71 180 472	1
96	Screw 4*25	571 903 403	4
100	Screw 2*8	941 134 166	2
194	Connector battery	571 905 550	1

fig 5-33

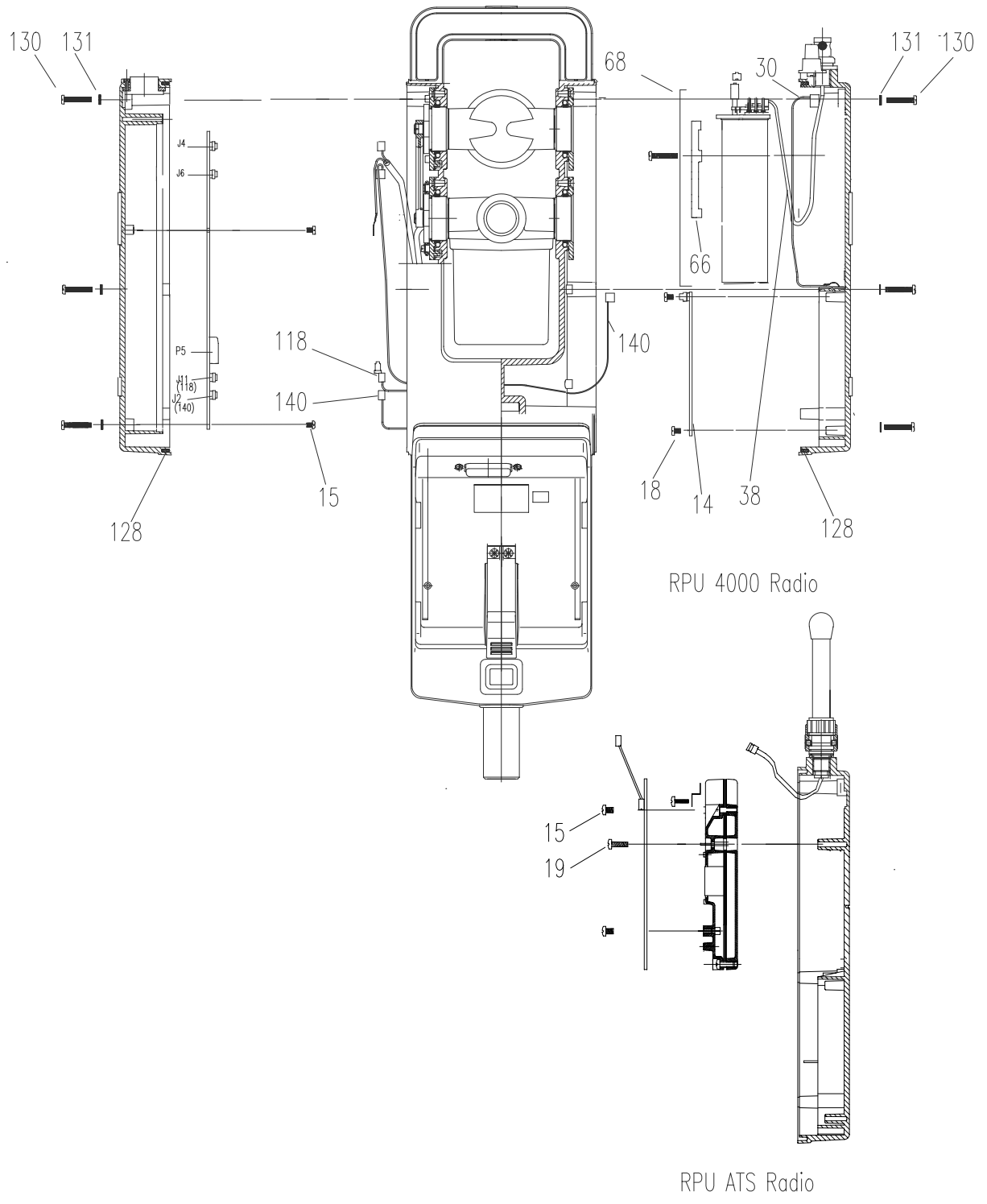

## RPU GDM 4000 &amp; ATS

Pos.	Description	Part.no:	Pcs.
14	Board RCL only RPU 4000	R71 180 210	1
15	Screw 2,5*6	571 903 074	5
18	Screw 4*9,5 only RPU 4000	571 901 388	4
19	Screw	571 901 706	4
30	Cable only RPU 4000	R71 181 276	1
38	Cable antenna with BNC connector only RPU 4000	R71 180 440	1
66	Bracket only RPU 4000	R71 180 208	1
68	Shield only RPU 4000	571 180 885	1
118	Cable RUB-CBO	R71 180 490	1
128	Sealing side cover	R71 180 209	1
130	Screw 3*30	571 903 075	12
131	Washer (50p)	R71 180 988	12
140	Cable RCOL-RUB	R71 207 046	1
	Side cover complete with radio L25 0,5 only RPU 4000	R71 180 610	1
	Side cover complete with radio H25 0,5 only RPU 4000	R71 180 611	1

For RPU ATS Georadio spare parts see Radio Maintenance Manual part.no: 571 908 259.



fig 5-34

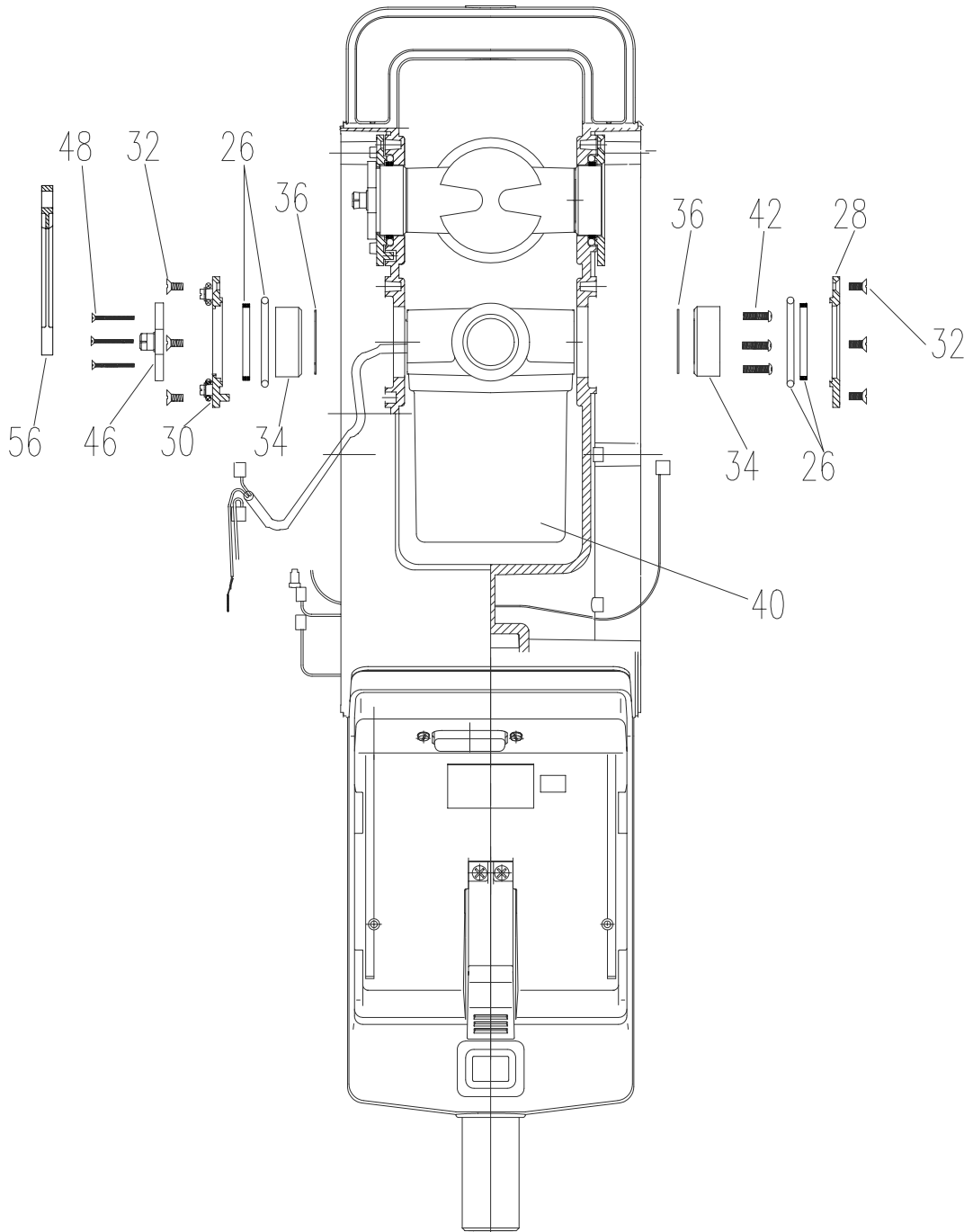

## RPU GDM 4000 &amp; ATS

Pos.	Description	Part.no:	Pcs.
26	Bearing	571 905 213	2
28	Bearing ring right	571 180 067	1
30	Bearing ring left	571 180 066	1
32	Screw 2,5*6	571 903 073	6
34	Axis	R71 180 068	2
36	Sealing	571 180 132	2
40	Angle unit complete (board RUB)	R71 180 454	1
42	Screw 2,5*16	571 905 164	3
46	Link holder	R71 180 069	1
48	Screw 2,5*20	571 905 168	3
56	Link	R71 180 130	1

## Targets

### Super prism standard - 571 125 021

fig 5-35

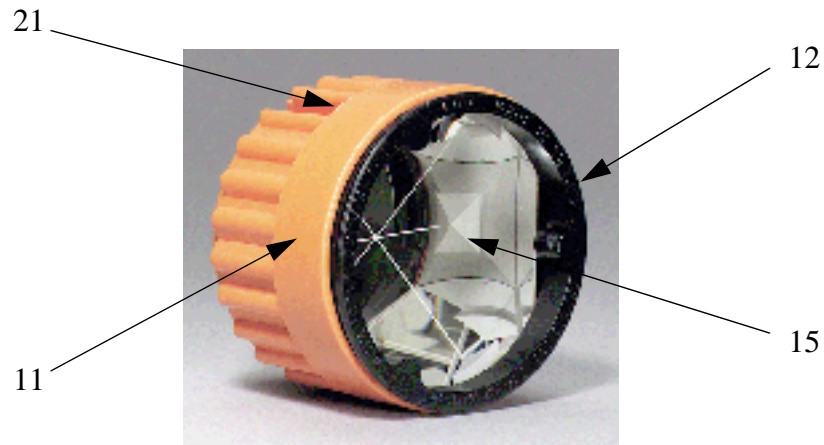

### Super prism standard - 571 125 021 Spare part list

Pos.	Description	Part.no:	Pcs.
11	Prism housing	R71 125 250	1
12	Ring	R71 125 251	1
15	Prism	R71 125 201	1
21	Screw 3*20	941 134 230	3

### Super prism sealed 571126 070

No parts available.

### Miniature prism - 571 126 060

fig 5-36

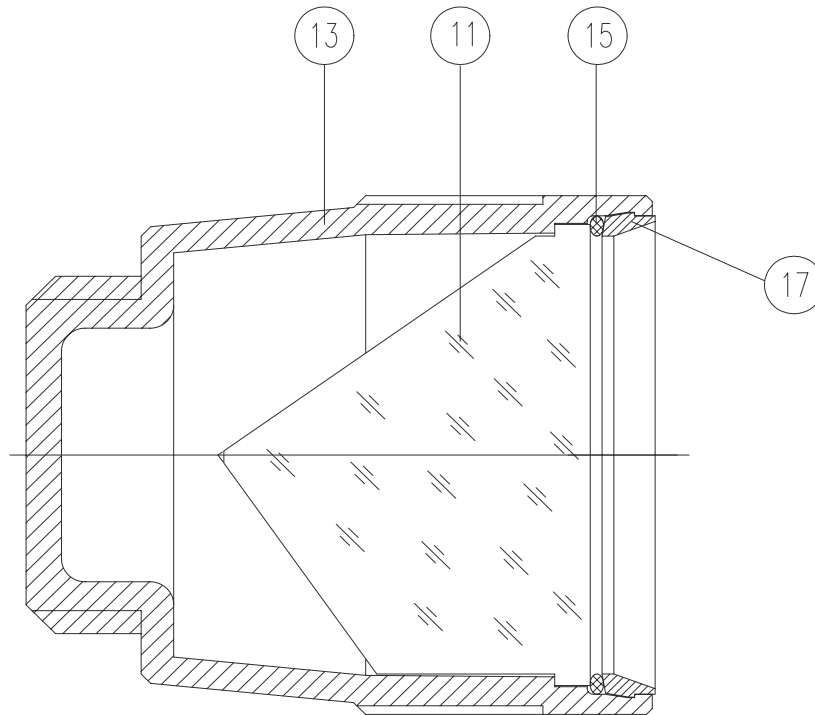

Miniature prism - 571 126 060

Pos.	Description	Part.no:	Pcs.
11	Prism	N/A	1
13	Prism housing	R71 126 062	1
15	O-Ring 39,2*1,6 (10p)	R71 905 798	1
17	Ring	R71 126 063	1
21	Rubber ring (Not shown in figure)	R71 126 103	1

### Small tiltable reflector - 571 126 100

fig 5-37

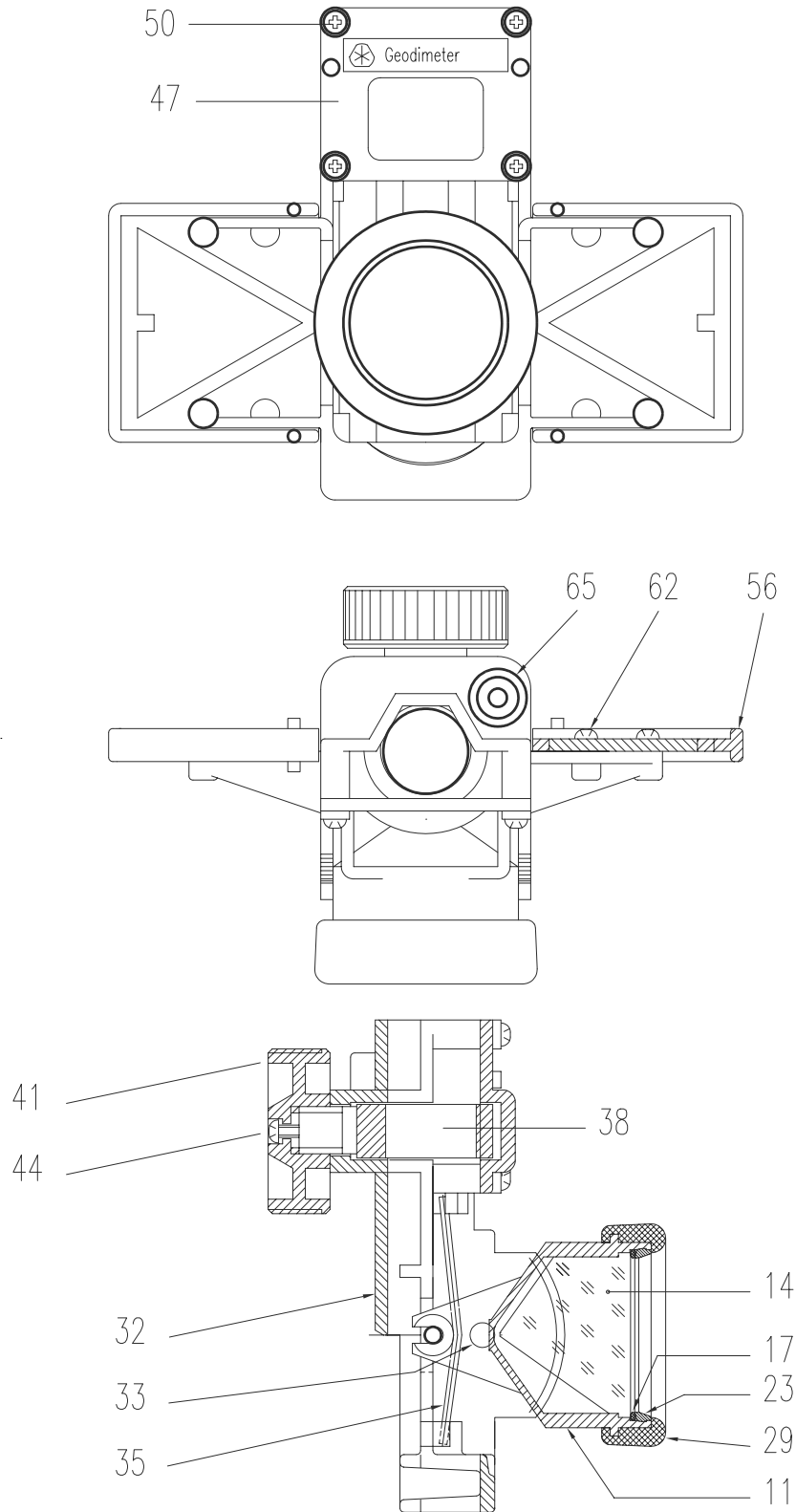

## Small tiltable reflector - 571 126 100

Pos.	Description	Part.no:	Pcs.
11	Prism housing	R71 126 102	1
14	Prism	N/A	1
17	O-Ring 38,4*1,6 (10p)	R71 905 563	1
23	Front ring (5p)	R71 126 063	1
29	Rubber ring (10p)	R71 126 103	1
32	Prism holder complete includes pos. 38, 41, 44, 47 and 50.	R71 126 210	1
33	Pin (10p)	R71 126 116	1
35	Spring (10p)	R71 126 115	2
38	Locking loop (10p)	R71 126 105	1
41	Knob	R71 126 106	1
44	Screw 3*14	571 903 214	1
47	Lid (5p)	R71 126 107	1
50	Screw 3*14	571 903 214	4
56	Sight mark	R71 126 108	2
62	Screw 3*8	571 903 211	8
65	Level	R71 905 814	1

### Large tiltable reflector - 571 126 110

fig 5-38

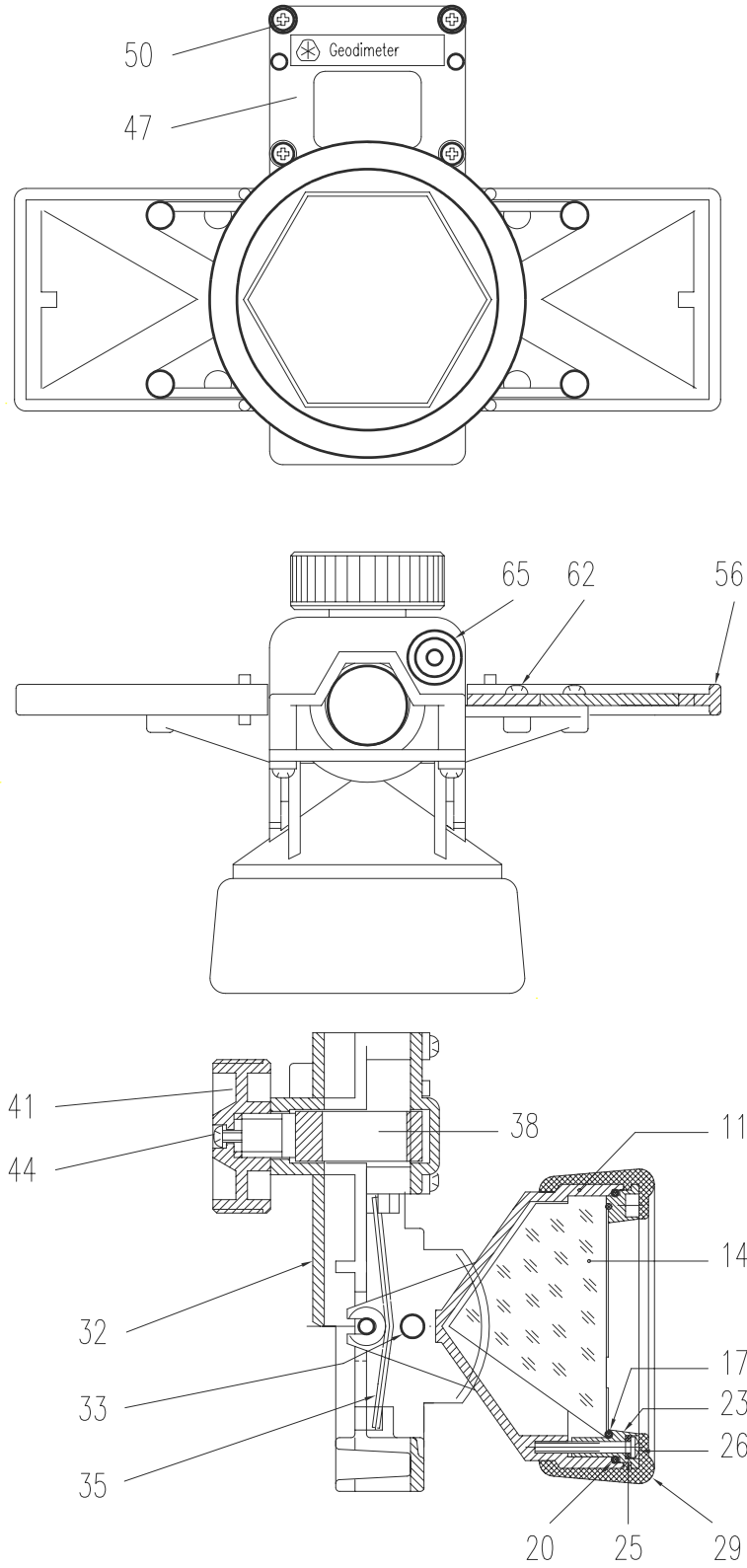

## Large tiltable reflector - 571 126 110

Pos.	Description	Part.no:	Pcs.
11	Prism housing	R71 126 112	1
14	Prism	N/A	1
17	O-Ring	R71 126 119	1
20	O-Ring 66,4*1,78	R71 905 912	1
23	Front ring (5p)	R71 126 113	1
25	O-Ring 2,9*1,78 (10p)	R71 901 892	3
26	Screw 3*25	571 903 218	3
29	Rubber ring	R71 126 114	1
32	Prism holder complete includes pos. 38, 41, 44, 47 and 50.	R71 126 210	1
33	Pin (10p)	R71 126 116	2
35	Spring (10p)	R71 126 115	2
38	Locking loop (10p)	R71 126 105	1
41	Knob	R71 126 106	1
44	Screw 3*14	571 903 214	1
47	Lid (5p)	R71 126 107	1
50	Screw 3*14	571 903 214	4
56	Sight mark	R71 126 184	2
62	Screw 3*8	571 903 211	8
65	Level	R71 905 814	1



### Large tiltable reflector - 571 126 140

fig 5-39

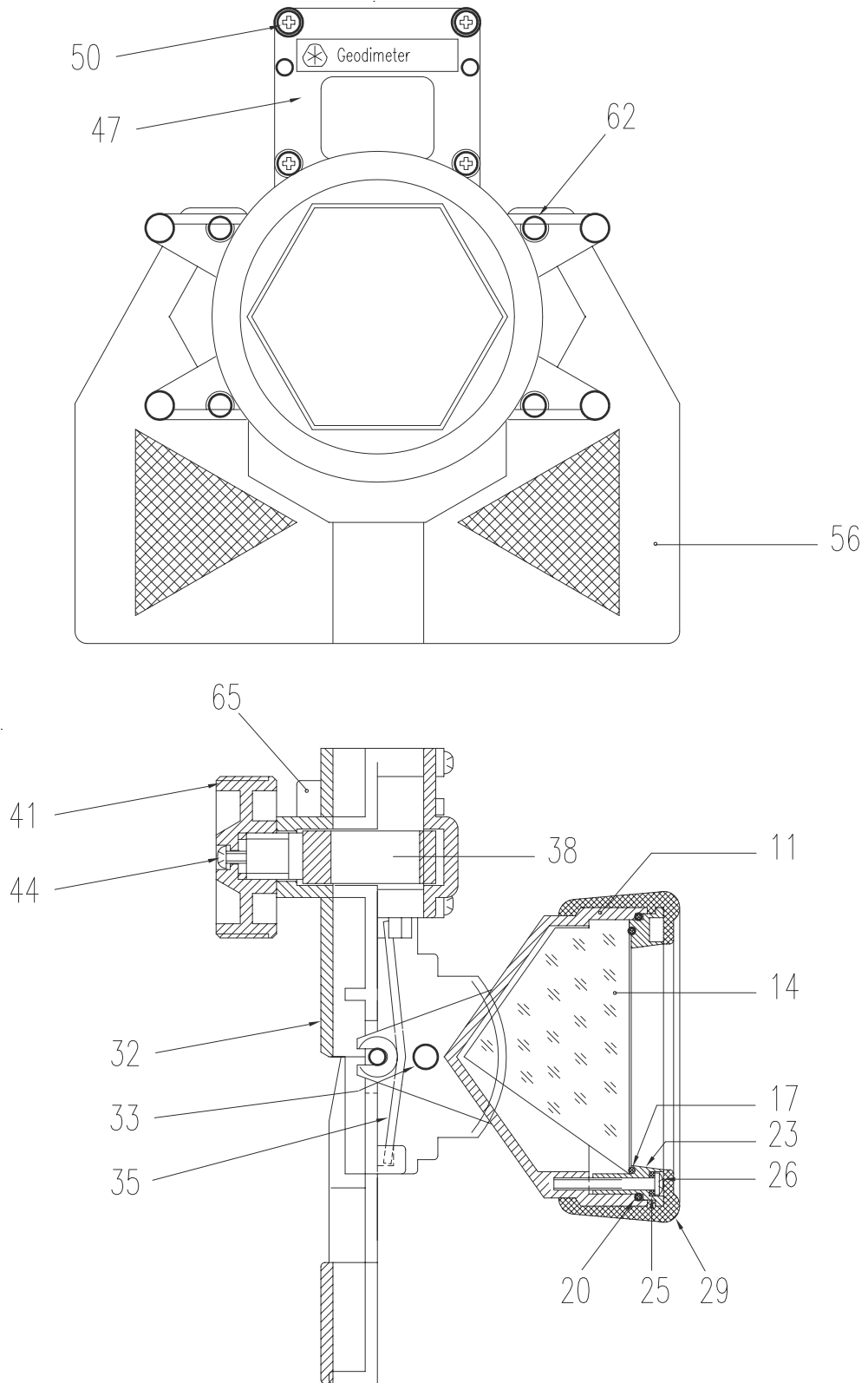

## Large tiltable reflector - 571 126 140

Pos.	Description	Part.no:	Pcs.
11	Prism housing	R71 126 112	1
14	Prism	N/A	1
17	O-Ring	R71 126 119	1
20	O-Ring 66,4*1,78	R71 905 912	1
23	Front ring (5p)	R71 126 113	1
25	O-Ring 2,9*1,78 (10p)	R71 901 892	3
26	Screw 3*25	571 903 218	3
29	Rubber ring	R71 126 114	1
32	Prism holder complete includes pos. 38, 41, 44, 47 and 50.	R71 126 210	1
33	Pin (10p)	R71 126 116	2
35	Spring (10p)	R71 126 115	2
38	Locking loop (10p)	R71 126 105	1
41	Knob	R71 126 106	1
44	Screw 3*14	571 903 214	1
47	Lid (5p)	R71 126 107	1
50	Screw 3*14	571 903 214	4
56	Sight mark	R71 125 745	1
62	Screw 3*8	571 903 211	8
65	Level	R71 905 814	1

### Small tiltable reflector - 571 126 150

fig 5-40

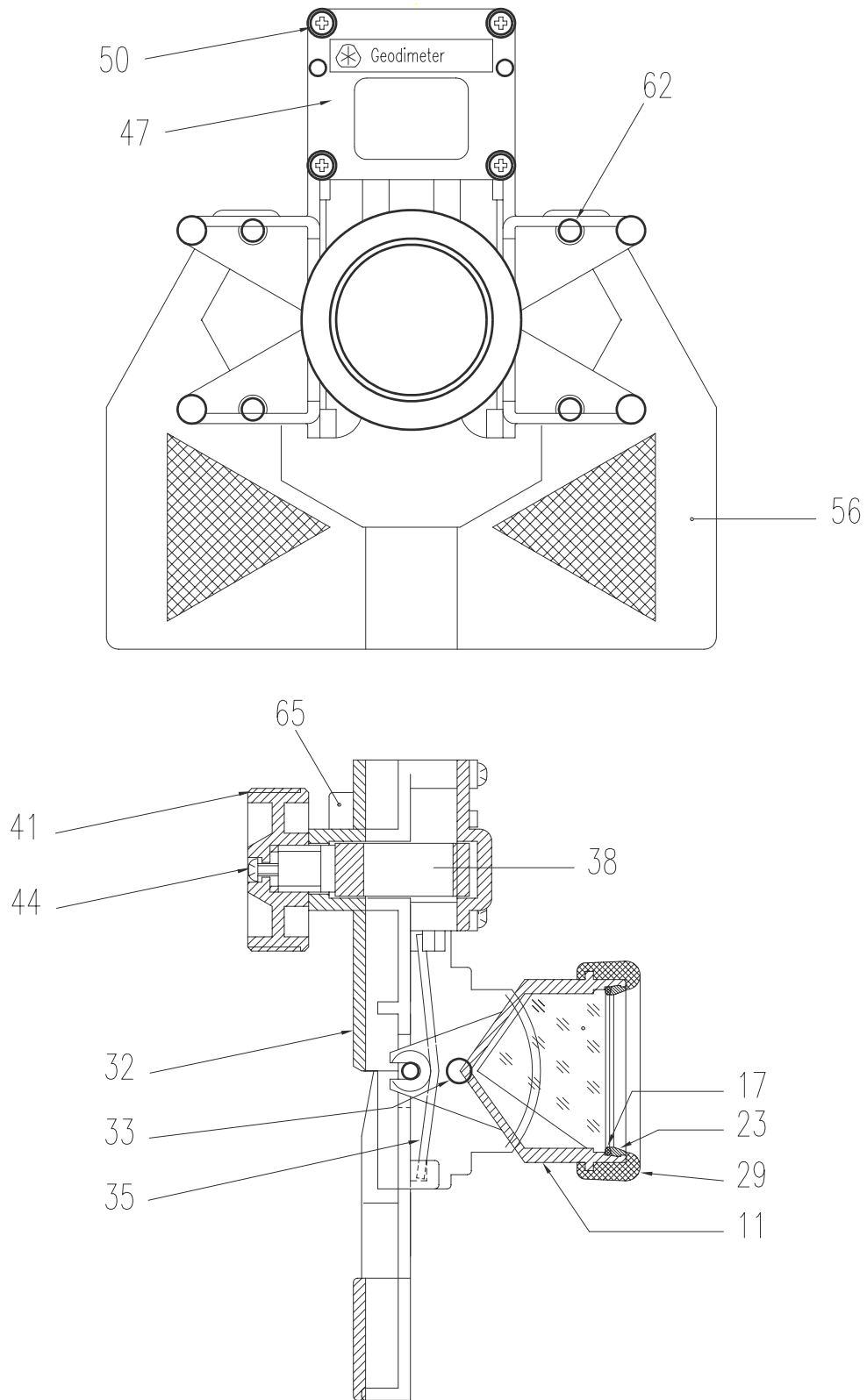

## Small tiltable reflector - 571 126 150

Pos.	Description	Part.no:	Pcs.
11	Prism housing	R71 126 102	1
14	Prism	N/A	1
17	O-Ring 38,4*1,6 (10p)	R71 905 563	1
23	Front ring (5p)	R71 126 063	1
29	Rubber ring (10p)	R71 126 103	1
32	Prism holder complete includes pos. 38, 41, 44, 47 and 50.	R71 126 210	1
33	Pin (10p)	R71 126 116	1
35	Spring (10p)	R71 126 115	2
38	Locking loop (10p)	R71 126 105	1
41	Knob	R71 126 106	1
44	Screw 3*14	571 903 214	1
47	Lid (5p)	R71 126 107	1
50	Screw 3*14	571 903 214	4
56	Sight mark	R71 125 745	1
62	Screw 3*8	571 903 211	8
65	Level	R71 905 814	1

## Mini Prism Kit - 571 126 273

fig 5-41

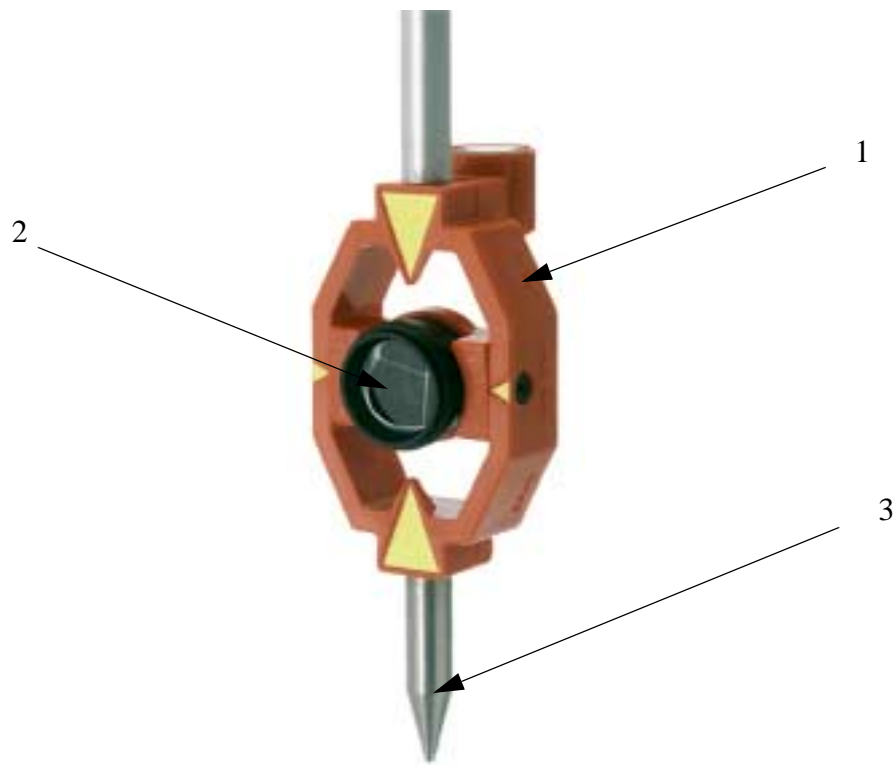

### Spare part list

Pos.	Description	Part.no:	Pcs.
1	Housing complete	R71 127 311	1
2	Prism 25,4 mm	R71 127 313	1
3	Tip	R71 127 312	1

# Tribrach

Tribrach - 571 900 680

Tribrach - 571 905 560

fig 5-42

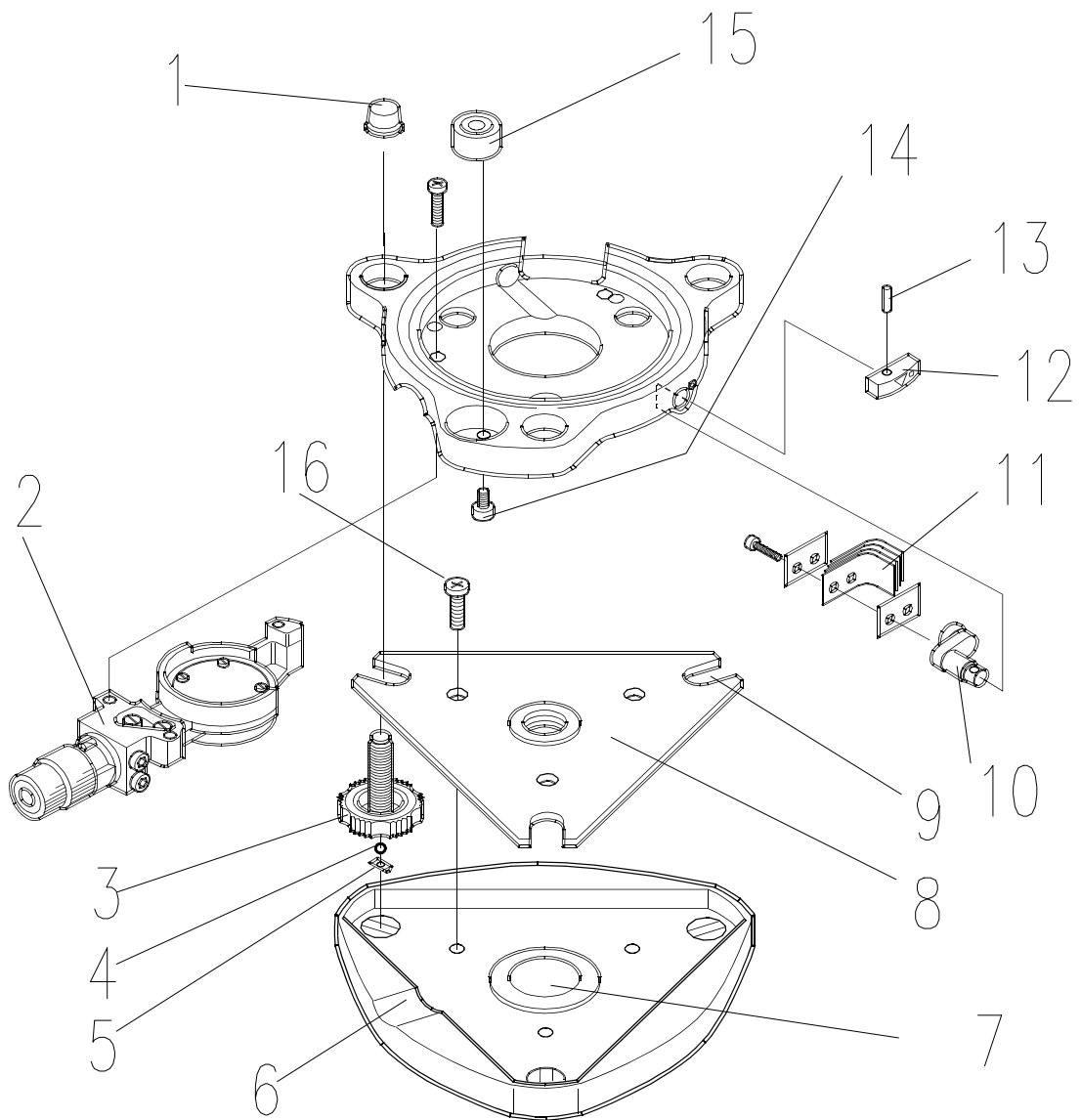

## Tribrach - 571 900 680

## Tribrach - 571 905 560

Pos.	Description	Part.no:	Pcs.
1	Cap	R71 903 801	3
2	Optical plumb complete	R71 908 157	1
3	Footscrew complete for 571 900 680	R71 904 161	3
3	Footscrew complete for 571 905 560	R71 905 934	3
4	Steel ball footscrew/slide only for 571 905 560 (20p)	R71 905 971	3
5	Slide footscrew/base plate only for 571 905 560 (10p)	R71 905 972	3
6	Base plate only for 571 900 680	R71 904 047	1
7	Locking washer	571 903 796	1
8	Support plate for 571 900 680	R71 905 236	1
8	Support plate for 571 905 560	R71 905 970	1
9	Insert for support plate R71 905 236 on 571 900 680	R71 903 794	3
10	Fastening arm	R71 903 800	1
11	Spring (10p)	R71 903 807	4
12	Handle	R71 903 799	1
13	Fitting pin 2,5*11	R44 128 208	1
14	Set screw for level	941 104 219	3
15	Level	R71 904 160	1
16	Screw 4*10	571 903 196	3

Tribrach - 571 900 680/2

Tribrach - 571 905 560/2

Tribrach - 571 908 823

fig 5-43

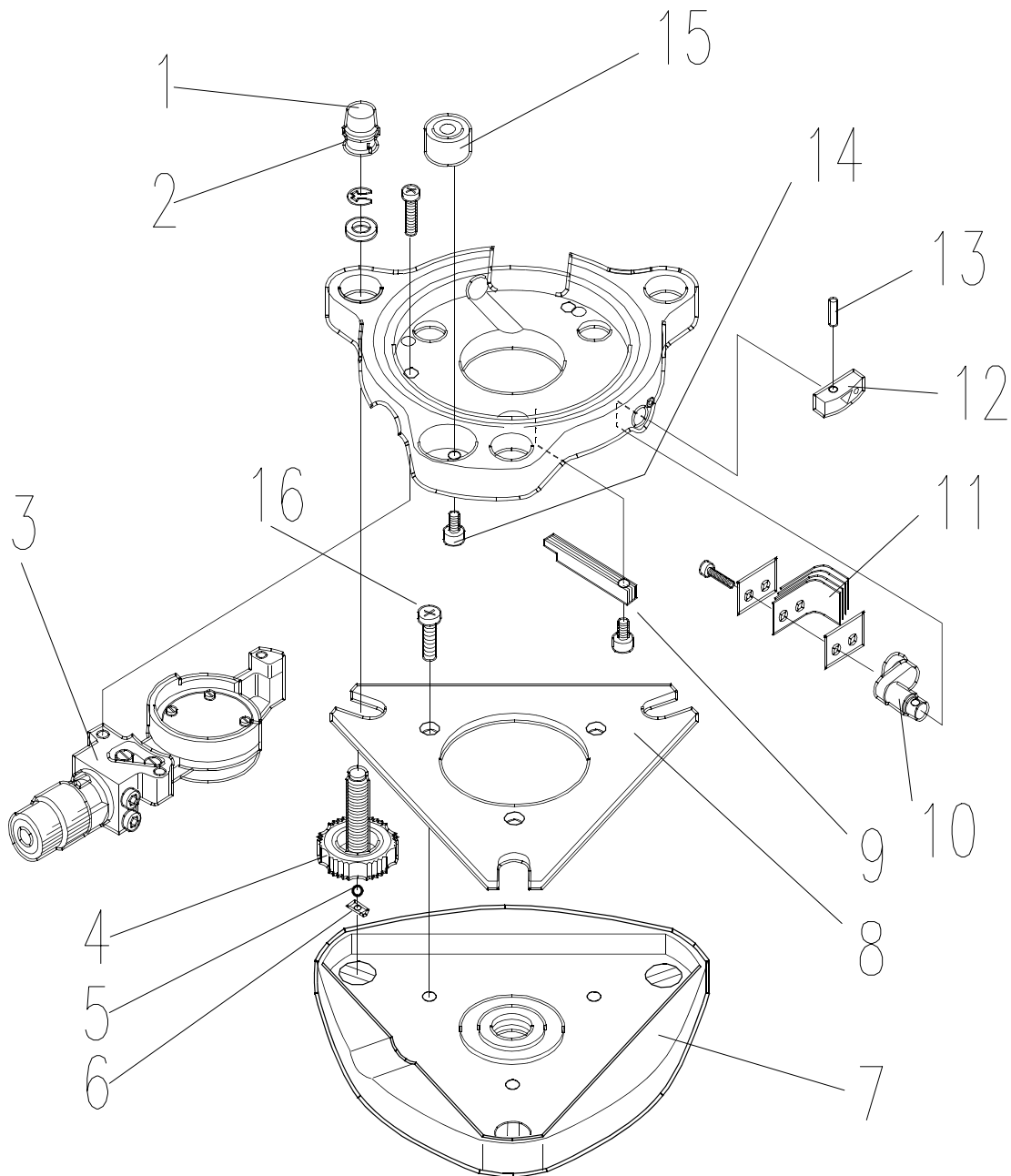



Tribrach - 571 900 680/2

Tribrach - 571 905 560/2

Tribrach 571 908 823

Pos.	Description	Part.no:	Pcs.
1	Cap	R71 908 152	3
2	O-Ring	571 908 153	3
3	Optical plumb complete for 571 900 680/2 & 571 905 560/2	R71 908 157	1
3	Laser plumb complete for 571 908 823	R71 908 159	1
4	Footscrew complete	R71 908 154	3
5	Steel ball footscrew/slide (20p)	R71 905 971	3
6	Slide footscrew/base plate (10p)	R71 905 972	3
7	Base plate	N/A	1
8	Support plate	R71 908 155	1
9	Spring only for 571 905 560/2	N/A	1
10	Fastening arm	R71 903 800	1
11	Spring (10p)	R71 903 807	4
12	Handle	R71 903 799	1
13	Fitting pin 2,5*11	R44 128 208	1
14	Set screw for level	941 104 219	3
15	Level	R71 908 151	1
16	Screw 4*10	571 903 196	3

# Tripod

## Tripod heavy duty

fig 5-44

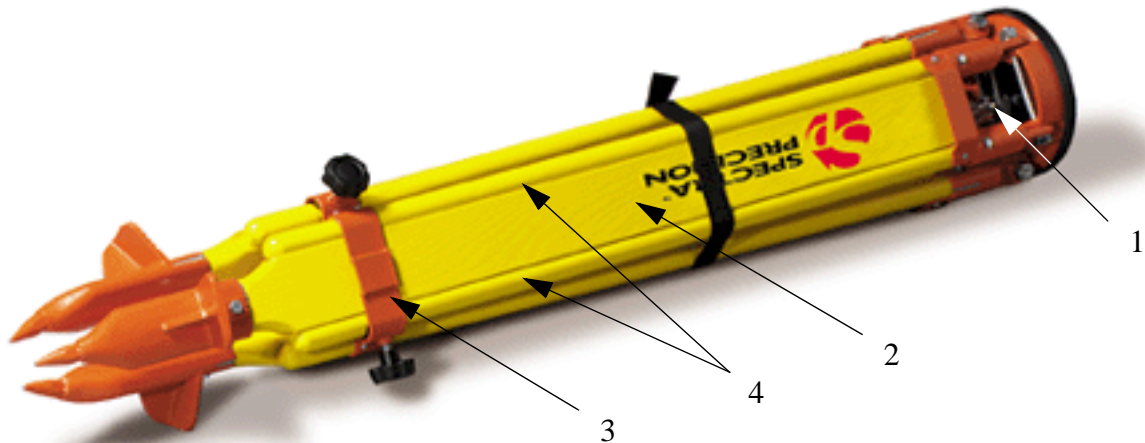

Tripod heavy duty - 571 126 275

Pos.	Description	Part.no:	Pcs.
1	Fastening screw for tribrach	R71 127 323	1
2	Leg for tripod	R71 127 322	3
3	Bracket for tripod leg with knob	R71 127 320	3
4	Leg-pins for tripod right & left	R71 127 321	3

Tripod heavy duty - 571 126 206

Pos.	Description	Part.no:	Pcs.
1	Fastening screw for tribrach	R71 126 219	1
2	Leg for tripod	R71 127 303	3
3	Bracket for tripod leg with knob	R71 127 304	3
4	Leg-pins for tripod right & left	R71 127 305	3

# GPS Antenna

## Compact antenna L1 - 571 212 240

fig 5-45

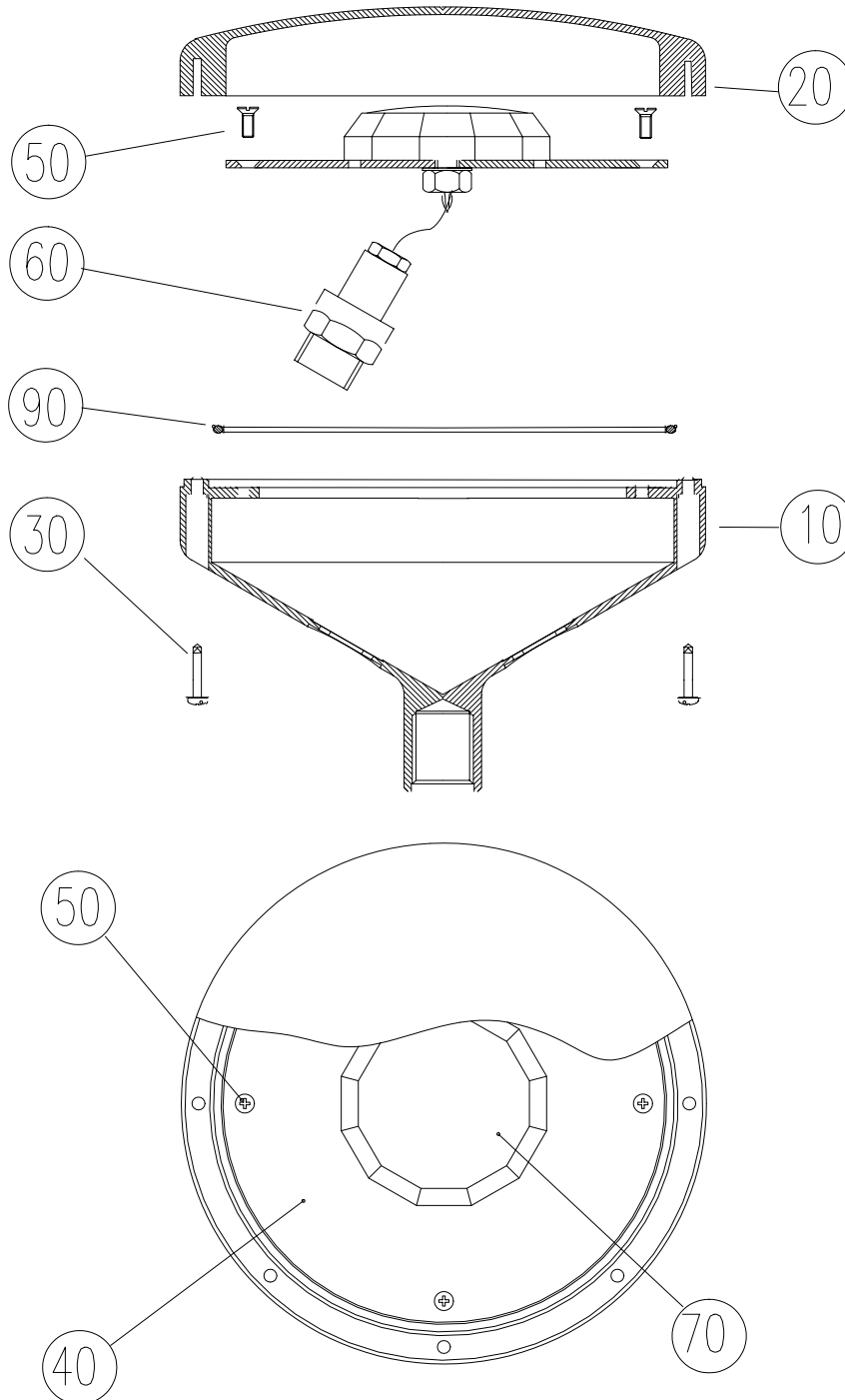

## Compact antenna L1 - 571 212 240

Pos.	Description	Part.no:	Pcs.
10	Antenna housing compact	571 212 432	1
20	Radome	R71 212 434	1
30	Screw 4*13	571 901 421	8
40	Ground plane compact antenna L1	R71 212 425	1
50	Screw 3*8	571 905 226	4
60	Connector N-Type	571 908 180	1
70	Antenna element L1	R71 212 023	1
90	Sealing 117*2,5	571 908 230	1

### Geodetic antenna L1 - 571 212 236

fig 5-46

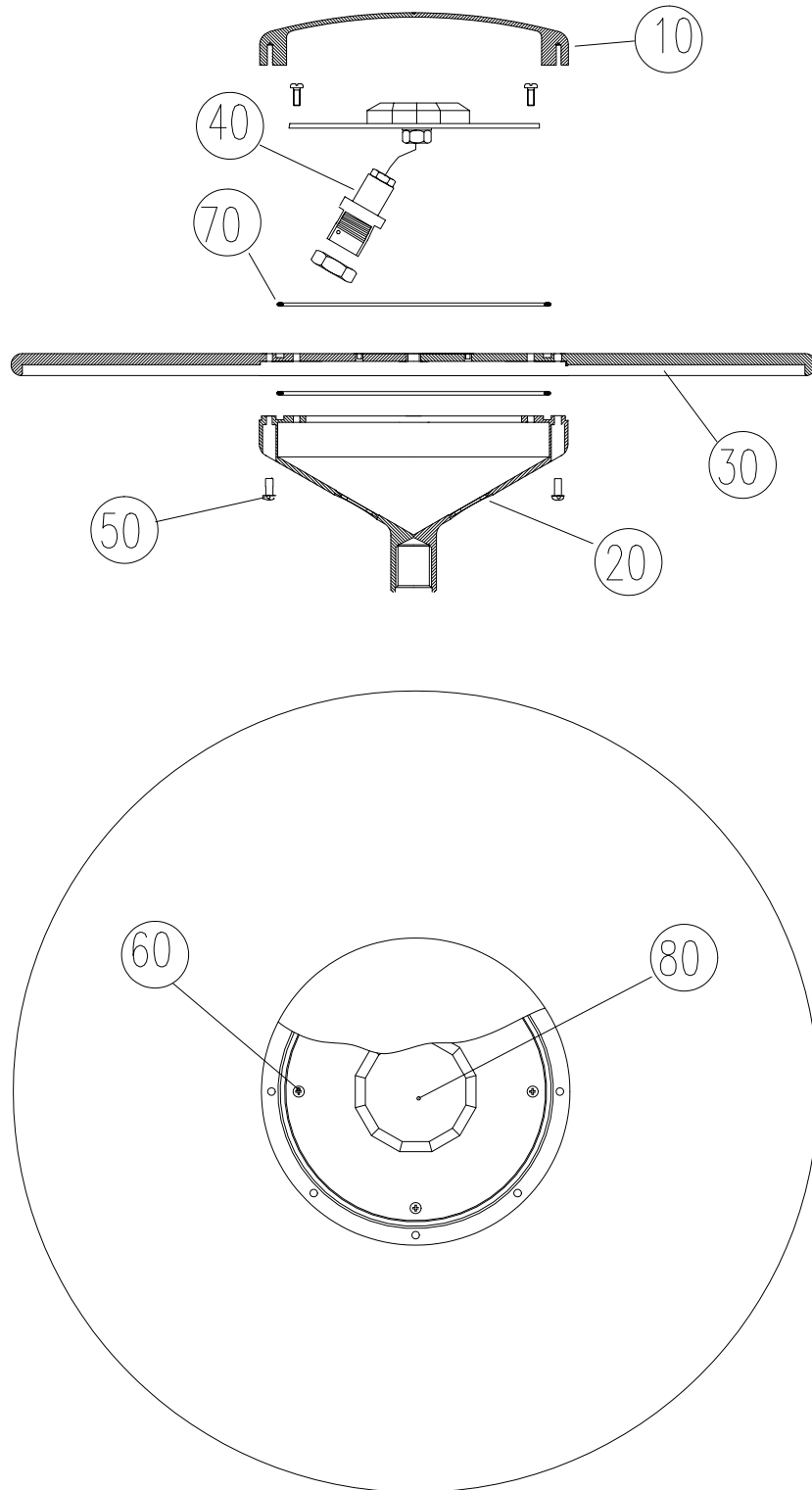

## Geodetic antenna L1 - 571 212 236

Pos.	Description	Part.no:	Pcs.
10	Radome	R71 212 434	1
20	Antenna housing Geodetic	571 212 437	1
30	Ground plane Geodetic antenna L1	R71 212 424	1
40	Connector N-Type	571 908 180	1
50	Screw 4*6	571 903 076	8
60	Screw 3*8	571 903 480	4
70	Sealing 117*2,5	571 908 230	2
80	Antenna element L1	R71 212 023	1

### Compact antenna L1/L2 - 571 212 430

fig 5-47

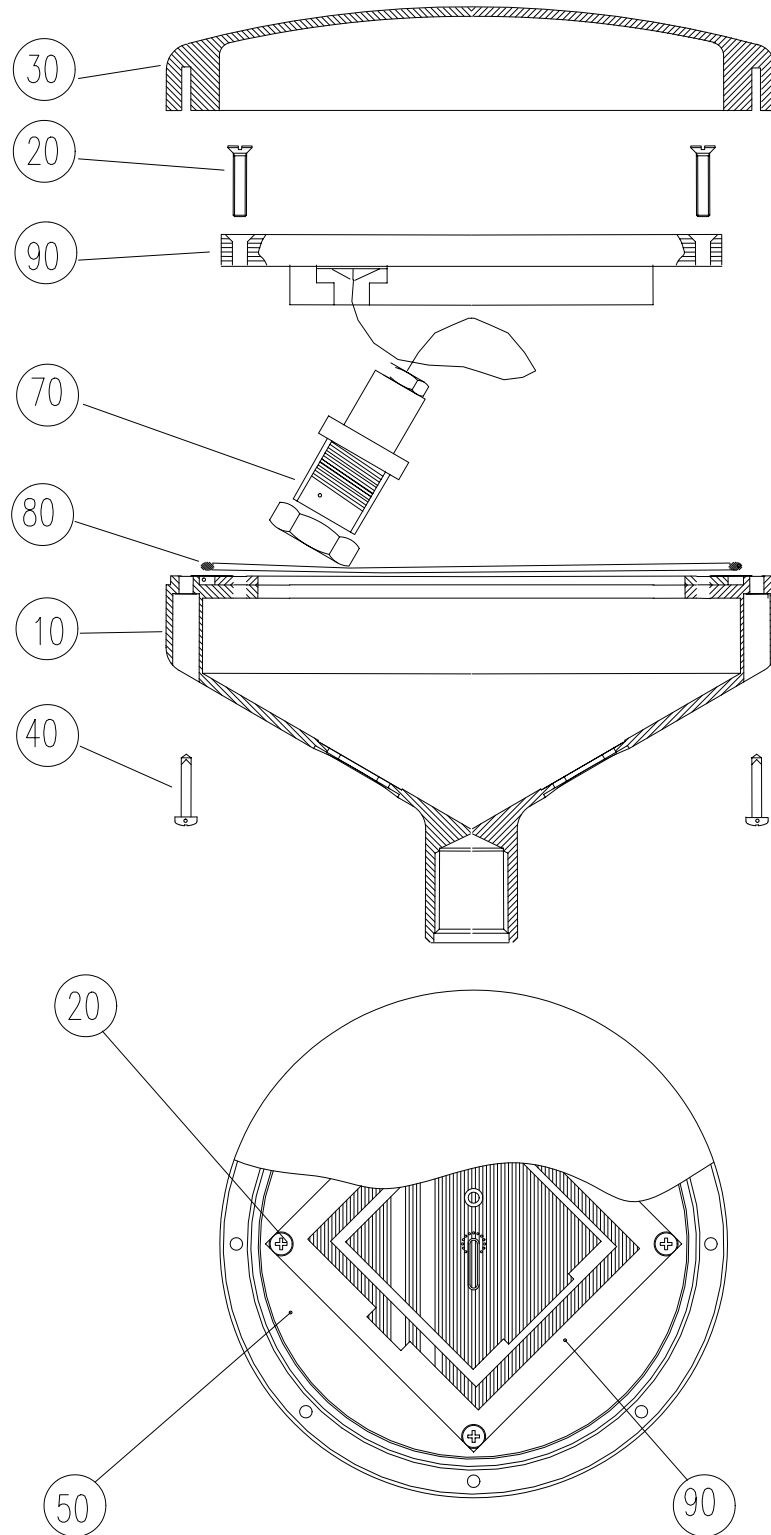

## Compact antenna L1/L2 - 571 212 430

Pos.	Description	Part.no:	Pcs.
10	Antenna housing compact	571 212 432	1
20	Screw 3*16	571 908 271	4
30	Radome	R71 212 434	1
40	Screw 4*13	571 901 421	8
50	Antenna ground plane compact L1/L2	R71 212 433	1
70	Connector N-Type	571 908 180	1
80	Sealing 117*2,5	571 908 230	1
90	Antenna element L1/L2	R71 908 149	1



### Geodetic antenna L1/L2 - 571212 238

fig 5-48

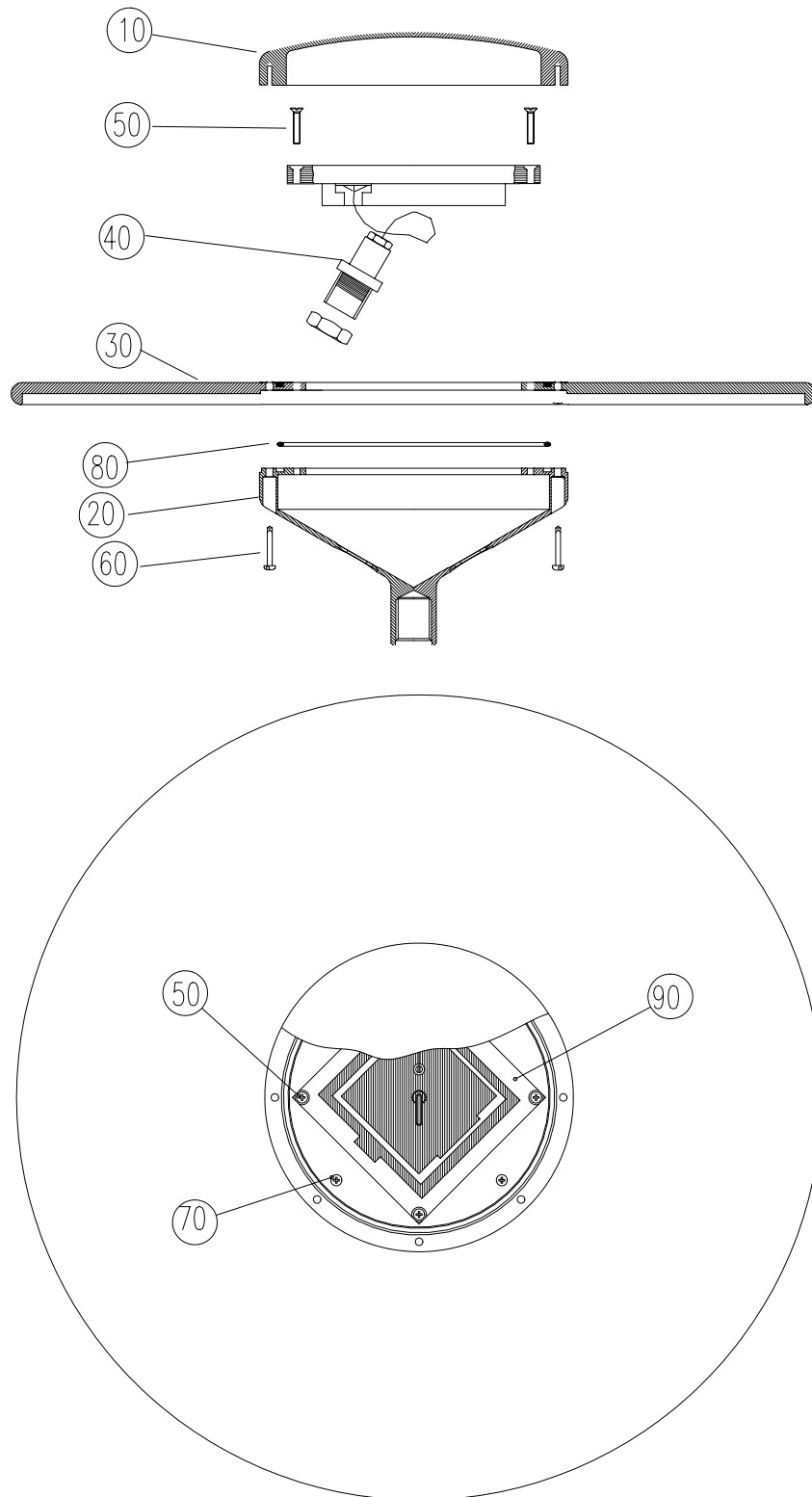

**Geodetic antenna L1/L2 - 571 212 238**

Pos.	Description	Part.no:	Pcs.
10	Radome	R71 212 434	1
20	Antenna housing geodetic	571 212 437	1
30	Antenna ground plane geodetic L1/L2	R71 212 438	1
40	Connector N-Type	571 908 180	1
50	Screw 3*16	571 908 271	4
60	Screw 4*16	571 903 076	8
70	Screw 3*8	571 903 480	4
80	Sealing 117*2,5	571 908 230	2
90	Antenna element L1/L2	R71 908 149	1

**Choke ring antenna L1/L2 - 571 212 426**

No spare parts available. Changed as complete unit.

**Mini geodetic antenna L1- 571 212 774**

No spare parts available. Changed as complete unit.

**Mini geodetic antenna L1/L2 - 571 212 777**

No spare parts available. Changed as complete unit.

**GPS/GLONASS antenna L1 - 571 212 791**

No spare parts available. Changed as complete unit.